



SLOVENSKI STANDARD
SIST ISO 10045:1995
01-december-1995

5`dg_Y`ga i]!`DcXfc `Ya cbHjY`j Ufbcglb] `j Yn]!`NU hYj Y`nUj]`U_Y`nU
dfYg_i y`Ub`Y

Alpine skis -- Binding mounting area -- Requirements for test screws

Skis alpins -- Zone de montage de la fixation -- Spécifications des vis d'essai

(standards.iteh.ai)

Ta slovenski standard je istoveten z: ISO 10045:1991

<https://standards.iteh.ai/catalog/standards/sist/b74e3801-1eaf-4568-8564-d0e169cb435a/sist-iso-10045-1995>

ICS:

97.220.20 Oprema za zimske športe Winter sports equipment

SIST ISO 10045:1995

en

iTeh STANDARD PREVIEW
(standards.iteh.ai)

SIST ISO 10045:1995

<https://standards.iteh.ai/catalog/standards/sist/b74e3801-1eaf-4568-8564-d0e169cb435a/sist-iso-10045-1995>

INTERNATIONAL STANDARD

ISO
10045

First edition
1991-07-15

Alpine skis — Binding mounting area — Requirements for test screws

iTeh STANDARD PREVIEW
(standards.iteh.ai)

*Skis alpins — Zone de montage de la fixation — Spécifications des vis
d'essai*

SIST ISO 10045:1995

[https://standards.iteh.ai/catalog/standards/sist/b74e3801-1eaf-4568-8564-
d0e169cb435a/sist-iso-10045-1995](https://standards.iteh.ai/catalog/standards/sist/b74e3801-1eaf-4568-8564-d0e169cb435a/sist-iso-10045-1995)



Reference number
ISO 10045:1991(E)

ISO 10045:1991(E)**Foreword**

ISO (the International Organization for Standardization) is a worldwide federation of national standards bodies (ISO member bodies). The work of preparing International Standards is normally carried out through ISO technical committees. Each member body interested in a subject for which a technical committee has been established has the right to be represented on that committee. International organizations, governmental and non-governmental, in liaison with ISO, also take part in the work. ISO collaborates closely with the International Electrotechnical Commission (IEC) on all matters of electrotechnical standardization.

Draft International Standards adopted by the technical committees are circulated to the member bodies for voting. Publication as an International Standard requires approval by at least 75 % of the member bodies casting a vote.

International Standard ISO 10045 was prepared by Technical Committee ISO/TC 83, *Sports and recreational equipment*.

SIST ISO 10045:1995

<https://standards.iteh.ai/catalog/standards/sist/b74e3801-1eaf-4568-8564-d0e169cb435a/sist-iso-10045-1995>

© ISO 1991

All rights reserved. No part of this publication may be reproduced or utilized in any form or by any means, electronic or mechanical, including photocopying and microfilm, without permission in writing from the publisher.

International Organization for Standardization
Case Postale 56 • CH-1211 Genève 20 • Switzerland

Printed in Switzerland

Introduction

The use of test screws ensures the comparability of measurement data, which are determined by the manufacturer or other institutions by testing the binding mounting area of alpine skis.

iTeh STANDARD PREVIEW (standards.iteh.ai)

[SIST ISO 10045:1995](https://standards.iteh.ai/catalog/standards/sist/b74e3801-1eaf-4568-8564-d0e169cb435a/sist-iso-10045-1995)

<https://standards.iteh.ai/catalog/standards/sist/b74e3801-1eaf-4568-8564-d0e169cb435a/sist-iso-10045-1995>

iTeh STANDARD PREVIEW
(standards.iteh.ai)

This page intentionally left blank

[SIST ISO 10045:1995](#)

<https://standards.iteh.ai/catalog/standards/sist/b74e3801-1eaf-4568-8564-d0e169cb435a/sist-iso-10045-1995>

Alpine skis — Binding mounting area — Requirements for test screws

1 Scope

This International Standard specifies the dimensions, mechanical properties and fastening characteristics of test screws used for testing the binding mounting area of alpine skis.¹⁾

2 Normative references

The following standards contain provisions which, through reference in this text, constitute provisions of this International Standard. At the time of publication, the editions indicated were valid. All standards are subject to revision, and parties to agreements based on this International Standard are encouraged to investigate the possibility of applying the most recent editions of the standards indicated below. Members of IEC and ISO maintain registers of currently valid International Standards.

ISO 1478:1983, *Tapping screws thread*.

ISO 4042:1989, *Threaded components — Electroplated coatings*.

ISO 4757:1983, *Cross recesses for screws*.

ISO 6004:1981, *Alpine skis — Ski binding screws — Requirements*.

ISO 6005:1981, *Alpine skis — Ski binding screws — Test methods*.

DIN 17 210:1984, *Case hardening steels — Technical delivery conditions*

3 Definitions

For the purposes of this International Standard, the definitions given in ISO 6004 and the following definition apply.

test screw: A fastener, which is used for testing the binding mounting area and for ensuring the comparability of measurement data.

4 Designation

Designation of a test screw according to this International Standard with a nominal diameter of 5,4 mm and a length of 12 mm:

Test screw ISO 10045 — TBS 5,4 × 12

5 Requirements

The strength requirements and typical application characteristics shall be tested according to ISO 6005.

5.1 Materials

1,1141 (= XC 18)

Ck 15 according to DIN 17 210 (= XC 15)

5.2 Dimensions

5.2.1 Screw head

Ski binding screws shall

- have a maximum head diameter of 10 mm, and
- be cross-recess type Z No. 3 according to ISO 4757, with a recommended penetration depth of 2,72 mm to 3,18 mm.

The bottom side of the head shall be coarse-toothed (see figure 1).

1) Details of suitable test screws and test assemblies can be obtained from the Secretariat of ISO/TC 83/SC 4 (ON, Austria) or from the ISO Central Secretariat.

ISO 10045:1991(E)

5.2.2 Thread and end configuration

The cross-section of the screw may be circular or non-circular within the major diameter of 5,31 mm to 5,46 mm (see figure 1).

The thread length shall be at least 1 mm longer than the penetration depth, irrespective of the shaft length. The tolerance on the length of the screw shall be $\pm 0,5$ mm.

The shaft end shall correspond to figure 1.

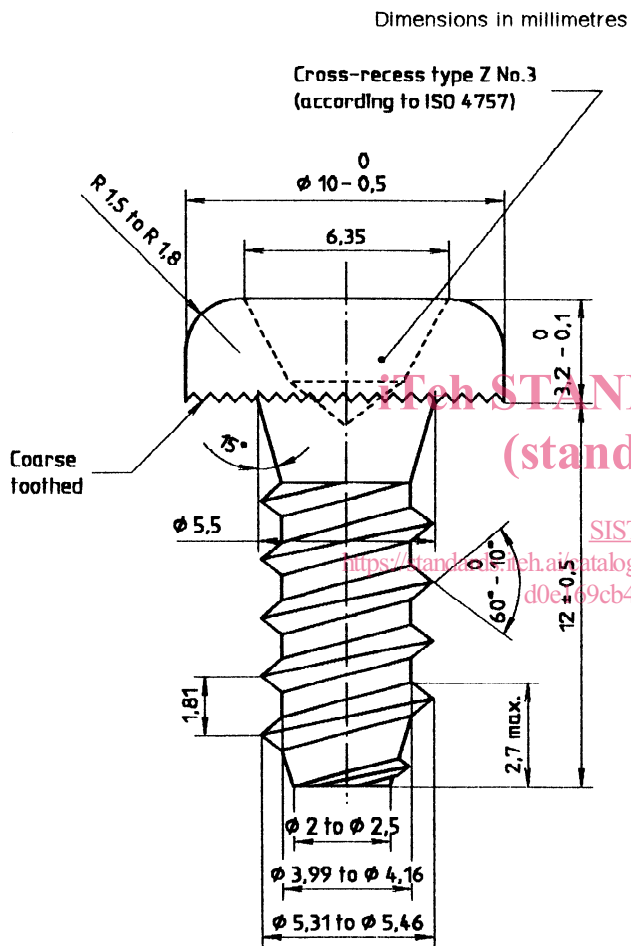

Figure 1 — Head, thread and end configuration

5.3 Surface

Test screws shall have a zinc electroplated coating, Fe/Zn 5c (see ISO 4042), with a clear chromate conversion coating and a thickness of 10 μ m when measured on the top surface of the screw head.

Adequate precautions shall be taken during electroplating to avoid hydrogen embrittlement.

5.4 Strength requirements

5.4.1 The breaking moment for ski binding screws under a torque of the same axis and direction as the driving torque shall be not less than 10 N.m.

5.4.2 When subjected to the ductility test, the screws shall not break.

5.5 Typical application characteristics

The specified fastening and mounting characteristics of the test screw are based on a uniform drill diameter of 4,1 mm H12.

5.5.1 Mounting characteristics

During the test, the screw shall obtain the following values without damage to the screw head:

Driving torque: 3,3 N.m max.

Stripping torque: 5 N.m min.

5.5.2 Fastening characteristics

The mean static pull-out resistance shall correspond to at least that of a reference screw complying with the requirements of ISO 1478, type F, and having a nominal diameter of 5,5 mm.