

INTERNATIONAL
STANDARD

ISO
10047

First edition
1993-04-01

**Textiles — Determination of surface
burning time of fabrics**

iTeh STANDARD PREVIEW
Textiles — Détermination de la durée de brûlage en surface des tissus
(standards.iteh.ai)

ISO 10047:1993

<https://standards.iteh.ai/catalog/standards/sist/a76053f5-d596-406d-90ee-3a8c92455930/iso-10047-1993>



Reference number
ISO 10047:1993(E)

Foreword

ISO (the International Organization for Standardization) is a worldwide federation of national standards bodies (ISO member bodies). The work of preparing International Standards is normally carried out through ISO technical committees. Each member body interested in a subject for which a technical committee has been established has the right to be represented on that committee. International organizations, governmental and non-governmental, in liaison with ISO, also take part in the work. ISO collaborates closely with the International Electrotechnical Commission (IEC) on all matters of electrotechnical standardization.

Draft International Standards adopted by the technical committees are circulated to the member bodies for voting. Publication as an International Standard requires approval by at least 75 % of the member bodies casting a vote.

International Standard ISO 10047 was prepared by Technical Committee ISO/TC 38, *Textiles*, Sub-Committee SC 19, *Burning behaviour of textiles and textile products*.

Annexes A and B form an integral part of this International Standard.

© ISO 1993

All rights reserved. No part of this publication may be reproduced or utilized in any form or by any means, electronic or mechanical, including photocopying and microfilm, without permission in writing from the publisher.

International Organization for Standardization
Case Postale 56 • CH-1211 Genève 20 • Switzerland

Printed in Switzerland

Textiles — Determination of surface burning time of fabrics

1 Scope

This International Standard specifies a method for the measurement of surface burning time of textile fabrics which have a raised fibre surface, i.e. a napped, pile, tufted, flocked or similar surface.

2 Definitions

For the purposes of this International Standard, the following definitions apply.

2.1 surface burn: Combustion limited to the surface of a material.

2.2 surface burning time: Time required for the pile or nap of a fabric to burn a defined distance when tested by the method described herein.

3 Principle

A dry specimen of the fabric is supported on a vertical plate and its raised surface is ignited near the top in a specified manner. The spread of flame downwards on the surface of the fabric to a reference line is timed.

NOTE 1 The flame of a pile surface travels more reproducibly downwards or sideways than upwards. It is considered that the blanketing effect of the combustion products may not allow the surface pile above the flame front to burn, whereas the surface pile below the flame front is not affected in this way.

4 Health and safety of test operators

Burning of textiles may produce smoke and toxic gases which can affect the health of operators. The

testing area shall be cleared of smoke and fumes by suitable means of forced ventilation after each test, then restored to the required testing conditions (see clause 6 and 8.1).

5 Apparatus and materials

5.1 Construction of testing equipment

The equipment shall be constructed of material which will not be adversely affected by the gas fumes.

Some products of combustion are corrosive, and the equipment shall be made of materials which will facilitate cleaning.

5.2 Specimen holder, consisting of a stainless steel plate approximately 150 mm long, 75 mm wide and 3 mm thick (see figure 1). The specimen shall be framed by stainless steel 3 mm thick so that an area of 125 mm × 50 mm of fabric surface is exposed for testing. The frame shall have a reference mark which shall be 75 mm below the ignition point of the test specimen.

5.3 Gas burner, as described in annex A.

NOTE 2 Small differences in the design and dimensions of the burner can influence the configuration of the burner flame and so affect the results of the tests.

5.4 Bottled gas, commercial grade propane or butane or mixtures thereof.

5.5 Timing device for burner, to control and measure the application time of the flame for a period of $1,0 \text{ s} \pm 0,1 \text{ s}$. Alternatively, flame application time may be manually controlled.

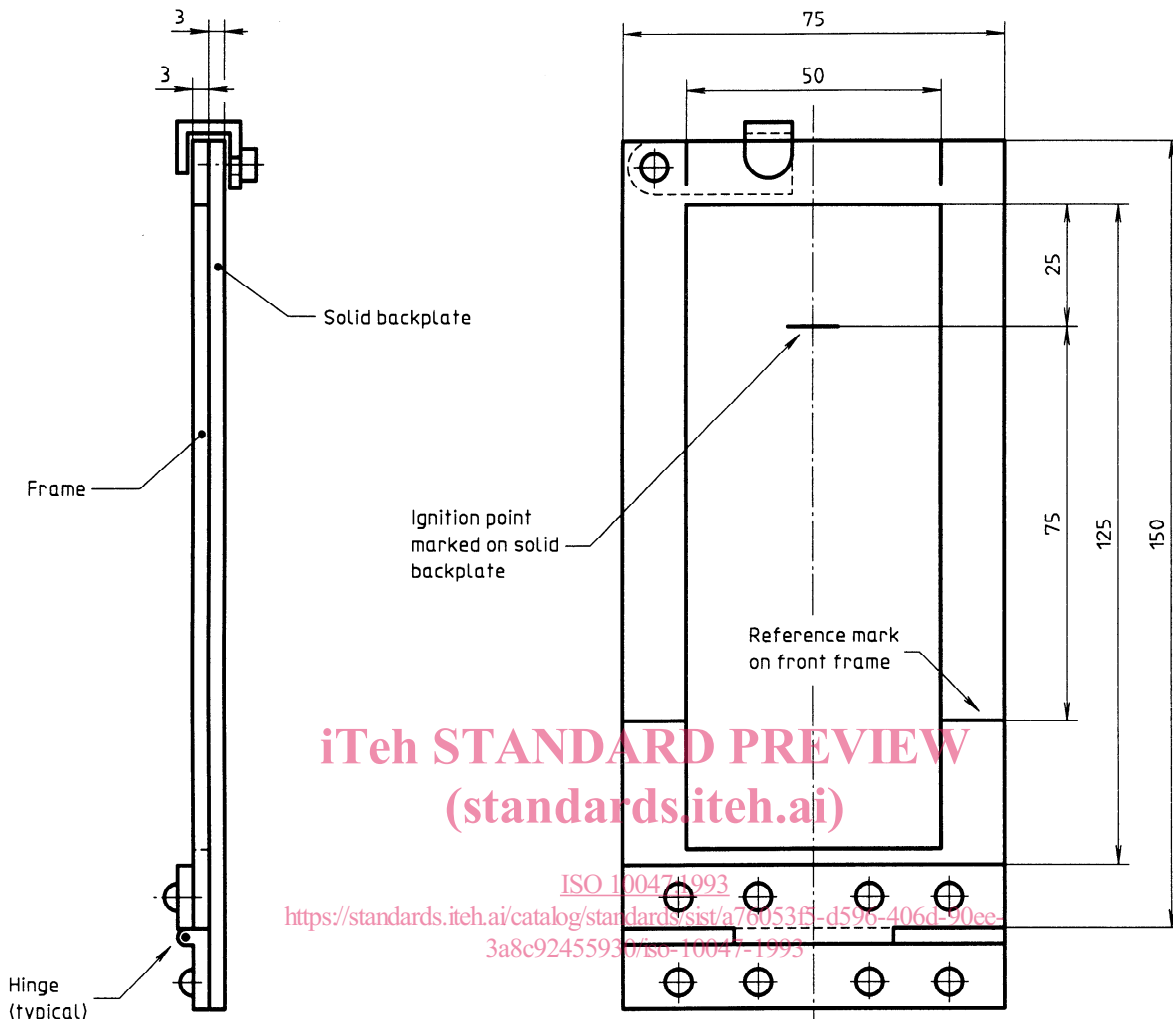

Figure 1 — Specimen holder

5.6 **Brushing device**, as described in annex B.

5.7 **Circulating air oven**, capable of drying the test specimens at $105\text{ °C} \pm 2\text{ °C}$.

5.8 **Desiccator**, capable of holding the dried test specimens.

5.9 **Stopwatch**, or other timing device accurate to 0,2 s.

6 Location of test

A location shall be used in which the air movement is less than 0,2 m/s at the commencement of the test and is not further influenced by mechanical devices during the test. The volume of air surrounding the test

location shall be such that the test is not affected by any reduction of oxygen concentration.

7 Preparation and conditioning of test specimens

7.1 Size

The size of each specimen shall be 150 mm x 75 mm, except that fabrics narrower than 75 mm shall be tested at their full width.

7.2 Number

A minimum of eight specimens shall be prepared for each surface to be tested, viz. four with their long dimension parallel to the length of the fabric and four

with their long dimension parallel to the width of the fabric, except that fabrics less than 150 mm wide shall be tested in one direction only, i.e. in the length direction.

7.3 State of fabric

If a fabric with a raised fibre surface does not exhibit surface burning when prepared from the "as received" state, another sample from which specimens shall be cut shall be cleansed by an appropriate procedure as agreed by the interested parties. These specimens shall be so identified.

7.4 Conditioning of test specimens

The specimens shall be dried in a circulating air oven (5.7) at $105\text{ °C} \pm 2\text{ °C}$ for not less than 1 h and then cooled in a desiccator (5.8) for not less than 30 min. Each specimen shall be tested within 1 min of removal from the desiccator.

8 Procedure

8.1 Carry out the test in an atmosphere having a temperature within the range 10 °C to 30 °C and 15 % to 80 % relative humidity.

8.2 Light the burner and preheat it for 2 min. Adjust the flame height to $40\text{ mm} \pm 2\text{ mm}$ measured as the distance between the top of the burner tube and the tip of the yellow part of the flame when the burner is vertically oriented and the flame is viewed in dim light.

8.3 Position the burner perpendicular to the surface of the vertical specimen holder so that the end of the burner is 15 mm from the surface of the specimen and the flame contacts the ignition point marked on the backplate. Mark the locations of the burner and the specimen holder so that the locations may be regained.

NOTE 3 It is convenient to control the gas to the burner through a solenoid valve. In such circumstances, it is permissible to leave a small pilot light 5 mm long on the burner.

8.4 Cool the specimen holder to within 5 °C of ambient temperature, and clamp the dried specimen in the holder so that the pile or nap points towards the bottom on the holder, if the pile is oriented in the length direction of the specimen.

8.5 Brush the raised fibre surface of the specimen once downwards and then once upwards with the brushing device described in annex B.

8.6 Return the specimen and the holder to the position located in 8.3.

8.7 Apply the flame to the specimen for $1,0\text{ s} \pm 0,1\text{ s}$ if a timing device is used. If flame application time is controlled manually, the burner shall be positioned so that the flame contacts the specimen, and then withdrawn.

If more than 1 min has elapsed since the specimen was removed from the desiccator, the specimen shall be re-dried.

8.8 Observe and record whether the surface pile or nap propagates any flame or ignites and if so, measure the time taken to burn to the reference mark which is 75 mm below the ignition point.

8.9 Carry out the test on each of the other specimens, making sure the holder is cool (see 8.4), clean and dry before each test.

8.10 If only one of the eight specimens tested exhibits surface burning, test a further set of eight specimens.

9 Test report

The test report shall contain the following information:

- a) that the test was carried out in accordance with this International Standard and details of alterations to it, if any;
- b) the width of the specimen, if less than 75 mm;
- c) the state of the specimens, i.e. "as received" or "cleansed", and any cleansing procedure used;
- d) the number of specimens (if any) which failed to surface burn to the reference mark;
- e) whether the surface pile or nap of any specimen propagates any flame;
- f) the individual times for the surface pile or nap to burn to the reference mark, the direction of the fabric, and the minimum value obtained. (If after retest in accordance with 8.10, only one specimen has burned to the reference mark, no time is reported.) If the surface pile or nap burns to the reference mark during the flame application time, the surface burning time shall be reported as less than 1 s;
- g) if the flame on the pile or nap is extinguished before reaching the reference mark;
- h) ambient conditions of temperature, relative humidity and barometric pressure in the area in which the test is carried out;
- i) date of the test;
- j) an explanatory statement as follows:

“These test results considered on their own do not indicate the fire hazard of the textile fabric under actual fire conditions and conse-

quently should not be applied to the assessment of fire hazard without taking into account additional supportive information.”

iTeh STANDARD PREVIEW
(standards.iteh.ai)

ISO 10047:1993

<https://standards.iteh.ai/catalog/standards/sist/a76053f5-d596-406d-90ee-3a8c92455930/iso-10047-1993>

Annex A (normative)

Description and construction of the burner¹⁾

A.1 Description

The burner provides a flame of suitable dimensions, the length of which can be regulated from 10 mm to 60 mm.

A.2 Construction

The construction of the burner is shown in figure A.1 a). The burner consists of the following three parts.

A.2.1 Gas jet

The orifice diameter of the gas jet [see figure A.1 b)] shall be $0,19 \text{ mm} \pm 0,02 \text{ mm}$. The orifice shall be drilled and after drilling, all burrs shall be removed from both ends of the drilled hole without rounding the corners.

A.2.2 Burner tube

The burner tube [see figure A.1 d)] consists of the following four zones:

- a) air chamber;
- b) gas mixing zone;
- c) diffusion zone;
- d) gas outlet.

Within the air chamber the burner tube has four air holes of 4 mm diameter for air inlet. The forward edge of the air holes is approximately level with the tip of the jet.

The diffusion zone is of conical shape and has the dimensions indicated in figure A.1 d). The burner has a bore of 1,7 mm inside diameter and an outlet of 3,0 mm inside diameter.

A.2.3 Flame stabilizer

The flame stabilizer is as detailed in figure A.1 c).

1) Names of sources of supply of such burners are available from national standards organizations.

Dimensions in millimetres

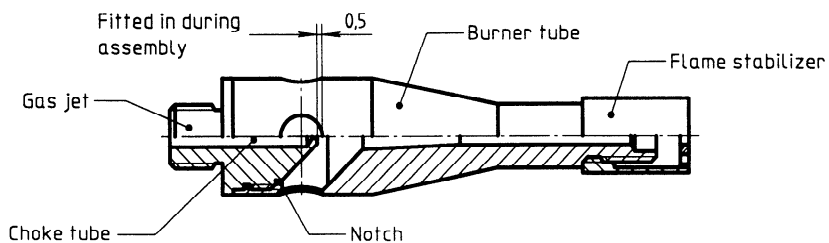

a) Gas burner arrangement

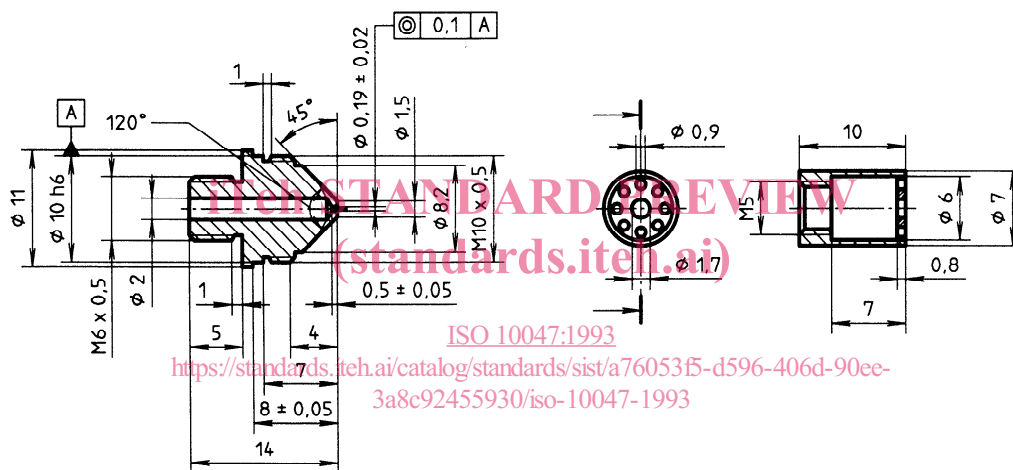

b) Gas jet

c) Flame stabilizer

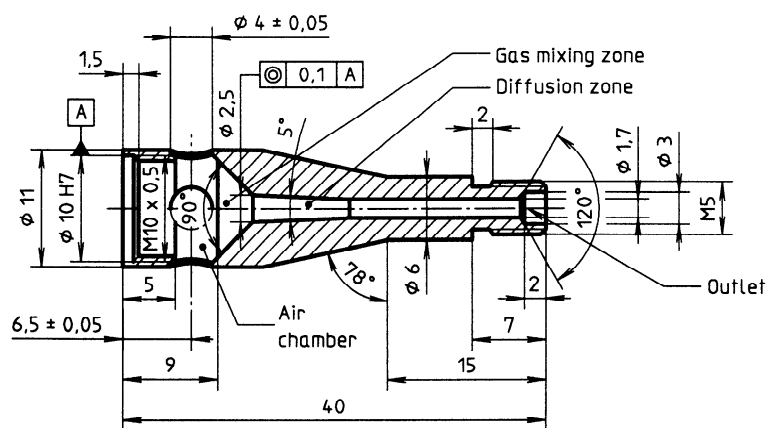

d) Burner tube

Figure A.1 — Gas burner