



## Standard Specification for Smooth-Wall Poly(Vinyl Chloride) (PVC) Conduit and Fittings for Underground Installation<sup>1</sup>

This standard is issued under the fixed designation F 512; the number immediately following the designation indicates the year of original adoption or, in the case of revision, the year of last revision. A number in parentheses indicates the year of last reapproval. A superscript epsilon ( $\epsilon$ ) indicates an editorial change since the last revision or reapproval.

### 1. Scope

1.1 This specification covers the requirements for smooth-wall poly(vinyl chloride) conduit and fittings for underground communication and electrical power wire and cables.

1.2 The values given in parentheses are for information only.

1.3 The following safety hazards caveat pertains only to the test method portion, Section 8, of this specification: *This standard does not purport to address all of the safety concerns, if any, associated with its use. It is the responsibility of the user of this standard to establish appropriate safety and health practices and determine the applicability of regulatory limitations prior to use.*

### 2. Referenced Documents

#### 2.1 ASTM Standards:

- D 618 Practice for Conditioning Plastics for Testing<sup>2</sup>
- D 1600 Terminology for Abbreviated Terms Relating to Plastics<sup>2,3</sup>
- D 1784 Specification for Rigid Poly(Vinyl Chloride) (PVC) Compounds and Chlorinated Poly(Vinyl Chloride) (CPVC) Compounds<sup>4,3</sup>
- D 2122 Test Method for Determining Dimensions of Thermoplastic Pipe and Fittings<sup>4</sup>
- D 2152 Test Method for Adequacy of Fusion of Extruded Poly(Vinyl Chloride) (PVC) Pipe and Molded Fittings by Acetone Immersion<sup>4</sup>
- D 2412 Test Method for Determination of External Loading Characteristics of Plastic Pipe by Parallel-Plate Loading<sup>4</sup>
- D 2444 Test Method for Determination of the Impact Resistance of Thermoplastic Pipe and Fittings by Means of a Tup (Falling Weight)<sup>4</sup>
- D 2466 Specification for Poly(Vinyl Chloride) (PVC) Plastic Pipe Fittings, Schedule 40<sup>4</sup>
- D 2564 Specification for Solvent Cements for Poly(Vinyl Chloride) (PVC) Plastic Piping Systems<sup>4</sup>
- D 2855 Practice for Making Solvent-Cemented Joints With

Poly(Vinyl Chloride) (PVC) Pipe and Fittings<sup>4</sup>  
F 412 Terminology Relating to Plastic Piping Systems<sup>4</sup>

### 3. Terminology

3.1 Definitions are in accordance with Terminology F 412 and abbreviations are in accordance with Terminology D 1600, unless otherwise specified. The abbreviation for poly(vinyl chloride) is PVC.

### 4. Classification

4.1 This specification covers four types of underground conduit. There are two having lesser pipe stiffness values, designed primarily for concrete encased burial (EB), and two with greater pipe stiffness values, designed primarily for direct burial (DB). The complete designations follow:

- Type EB-20 — Designed to be encased in concrete.
- Type EB-35 — Designed to be encased in concrete.
- Type DB-60 — Designed for direct burial without encasement in concrete.
- Type DB-100 — Designed for direct burial without encasement in concrete.
- Type DB-120 — Designed for direct burial without encasement in concrete.

4.2 This specification covers conduit with integral bells, or with either separate or attached couplings.

4.3 This specification covers molded and fabricated fittings intended for use with all types of conduit.

### 5. Materials

5.1 *Basic Materials*—The conduit shall be made of virgin homopolymer PVC compound having a cell classification of 12254-A or B, 12164-B<sup>5</sup> (with a minimum tensile strength of 4000 psi (28 MPa)), or 12264-A or B (with a minimum tensile modulus of 500 000 psi) as defined in Specification D 1784. Molded fittings shall be made from PVC compound having a cell classification of 12234-B, 12234-C, or 13343-C as defined in Specification D 1784. Homopolymer PVC compounds must equal or exceed the requirements of the listed cell classification numbers.

5.2 *Rework Materials*—Rework material from the manufacturer's own conduit or fittings production may be used by the same manufacturer, provided that the conduit or fittings produced meet all of the requirements of this specification.

5.3 *Solvent Cement*—The solvent cement shall meet the requirements of Specification D 2564.

<sup>1</sup> This specification is under the jurisdiction of ASTM Committee F17 on Plastic Piping and is the direct responsibility of Subcommittee F17.25 on Vinyl Based Pipe. Current edition approved Sept. 10, 1995. Published November 1995. Originally published as F 512 – 77. Last previous edition F 512 – 93.

<sup>2</sup> *Annual Book of ASTM Standards*, Vol 08.01.

<sup>3</sup> *Annual Book of ASTM Standards*, Vol 08.02.

<sup>4</sup> *Annual Book of ASTM Standards*, Vol 08.04.

<sup>5</sup> Supporting data are available at ASTM Headquarters. Request RR:F17-1002.

**6. Requirements**

6.1 *Workmanship*—The conduit and fittings shall be homogeneous throughout, and free from visible cracks, holes, foreign inclusions, or other injurious defects. The conduit and fittings shall be as uniform as is commercially practical in color, opacity, density, and other physical properties.

6.2 *Dimensions:*

6.2.1 Dimensions shall be determined in accordance with Test Method D 2122.

6.2.2 The dimensions and tolerances of the conduit shall be as specified in Table 1.

6.2.3 *Lengths*—Conduit shall be supplied in lengths of 20 or 25 ft, or as otherwise agreed upon between the purchaser and the seller. A length shall be considered to be the overall length of the conduit, including integral bell, or coupling if attached, unless otherwise specified. Tolerance on length shall be  $\pm 1$  in. ( $\pm 25$  mm).

6.2.4 *Integral Bell Dimensions:*

6.2.4.1 Two systems of fit for integral bells are in common use. Unless otherwise specified, the manufacturer may employ either of them.

6.2.4.2 *Interference Fit System*—The dimensions and tolerances listed in Columns A and B of Table 1 in Specification D 2466 provide a satisfactory interference fit system between pipe and socket.

6.2.4.3 *Clearance Fit System*—The dimensions and tolerances listed in Table 2 of this specification provide a satisfactory clearance fit system.

6.2.5 The wall thickness of integral bells and sweeps shall be considered satisfactory if formed from conduit which meets the minimum requirements of this specification.

6.2.6 Socket depths for integral bells shall conform to the requirements listed in Table 2.

6.2.7 Integral belled ends shall be centered to provide a visible shoulder around the entire circumference.

6.2.8 The inside diameters of spigot ends shall be chamfered as shown in Fig. 1.

6.2.9 *Fittings and Sweep Dimensions:*

6.2.9.1 The dimensions and types of conduit fittings shall be as specified in Tables 3-17.

6.2.9.2 Conduit fittings shall be capable of passing a ball  $\frac{1}{4}$  in. (6 mm) less in diameter than the nominal size of the conduit.

6.2.9.3 The dimensions of sweeps and bends shall be as specified in Table 17. Sweeps and bends shall be made from DB-60 or DB-120 conduit. Sweeps made from DB-60 conduit

are intended for use with EB-20 and DB-60 conduit. Sweeps made from DB-120 conduit are intended for use with EB-35 and DB-120 conduit.

6.3 *Minimum Pipe Stiffness:*

6.3.1 The minimum pipe stiffness ( $F/\Delta y$ ) values for conduit shall be in conformance with Table 18, when tested in accordance with 8.3. Three specimens shall be tested, all shall meet the requirements.

6.3.2 *Referee Test*—The minimum pipe stiffness ( $F/\Delta y$ ) values shall be in accordance with Table 18 when tested in accordance with Test Method D 2412 at 5 % deflection.

6.4 *Impact Strength*—The minimum drop weight impact strength values for conduit shall be as listed in Table 19, when tested in accordance with 8.1.

6.4.1 The impact test is a quality control test, to be performed at the time of manufacture.

6.5 *Joint Tightness (Referee Test)*—The joints shall not leak when tested in accordance with 8.2.

6.6 *Extrusion Quality*—The conduit shall not flake or disintegrate when tested in accordance with Test Method D 2152.

**7. Conditioning**

7.1 *Referee Testing*—When conditioning is required for referee tests, condition the specimens in accordance with Procedure A in Methods D 618 at  $23 \pm 2^\circ\text{C}$  and  $50 \pm 5\%$  relative humidity for not less than 40 h prior to test. Conduct tests under the same conditions of temperature and humidity, unless otherwise specified.

7.2 *Quality Control:*

7.2.1 For quality control tests, condition specimens for a minimum of 3 h in air, or 1 h in liquid at  $23 \pm 2^\circ\text{C}$  ( $70$  to  $77^\circ\text{F}$ ). Test the specimens at  $23 \pm 2^\circ\text{C}$  without regard to relative humidity.

7.2.2 For the impact test, condition specimens for at least 30 min at  $0$  to  $1.6^\circ\text{C}$  ( $32$  to  $35^\circ\text{F}$ ).

**8. Test Methods**

8.1 *Impact Resistance*—Test and evaluate five specimens, each  $6 \pm \frac{1}{16}$  in. ( $150 \pm 2$  mm) long, in accordance with Test Method D 2444, using a 20-lb Tup B, and the flat plate (Holder B). When testing is performed at temperatures above  $0^\circ\text{C}$ , no more than 15 s shall elapse from the time of removal of the specimen from the conditioning medium until completion of that test. Specimens may be positioned with a random surface uppermost, but must be located so that the contact point is centered. All five specimens shall pass. If one specimen fails, test another five specimens: nine out of ten specimens passing shall be acceptable.

8.2 *Joint Tightness (Referee Test)*—Cement a section of conduit to a bell, using the manufacturer's recommendations or, in their absence, the methods described in Practice D 2855. Unless otherwise specified, allow the assembly to stand for at least 6 h. Then subject the assembly to an internal pressure of at least 25 psi (170 kPa), using water as the test medium. Maintain the pressure for at least 1 h. There shall be no leakage.

8.3 *Pipe Stiffness*—Determine the pipe stiffness ( $F/\Delta y$ ) at 5 % deflection of inside diameter, as described in Test Method D 2412. Test three specimens each  $6 \pm \frac{1}{16}$  in. ( $150 \pm 2$  mm)

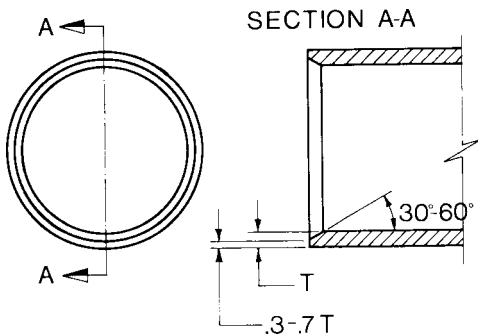

FIG. 1 Chamfer Detail

long. Place each specimen so that the minimum wall thickness is uppermost (adjacent to the top bearing plate). Measure the vertical inside diameter before compressing the specimen. Compress the specimen at the rate of ½ in. (13 mm)/min, and record the load at the point where the vertical inside diameter is equal to 95 % of the original inside diameter of the specimen.

### 9. Inspection

9.1 Inspection of the material shall be made as agreed upon between the purchaser and the seller as part of the purchase contract.

### 10. Retest and Rejection

10.1 If the results of any test(s) do not meet the requirements of this specification, the test(s) may be conducted again in accordance with an agreement between the purchaser and the seller. There shall be no agreement to lower the minimum requirement of the specification by such means as omitting tests that are a part of the specification, substituting or modifying a test method, or by changing the specification limits. In retesting, the product requirements of this specification shall be met, and the test methods designated in the specification shall be followed. If, upon retest, failure occurs, the quantity of product represented by the test(s) does not meet the requirements of this specification.

### 11. Certification

11.1 A manufacturer shall provide certification that the product was manufactured in accordance with the requirements of this specification signed by an authorized agent, provided that the user, purchaser, or specifying agency, or combination thereof, so request in the purchase order or contract. Furthermore, when agreed upon between the manufacturer and the user, purchaser, or specifying agency, or combination thereof, and preferably prior to the date of manufacture, the manufacturer shall provide test data and the date on which tests were conducted for a specific lot or shipment of product made under this specification.

### 12. Product Marking

12.1 Conduit shall be clearly marked with the manufacturer's name or trademark, PVC cell classification (that is: PVC 12254-A, PVC 12254-B, PVC 12164-B, PVC 12264-A, or

PVC 12264-B), size, type of conduit (for example, DB-60), the minimum wall thickness, code or control number, and this designation "ASTM F 512" at intervals of 5 ft (1.5 m) or less. Any additional marking deemed necessary by the manufacturer is permitted.

12.2 Sweeps and bends shall be made from conduit that is marked in accordance with 11.1. In addition, the bend radius and the degrees shall be marked (for example, 18" R —30° for 18-in. radius 30° bend).

12.3 Fittings shall be marked with the manufacturer's name or trademark, the conduit size, the phrase "PVC," and this designation "ASTM F 512." Where fitting size does not permit legible marking, the packaging shall carry the designated information.

12.4 The minimum letter size permitted on conduit, sweeps, and bends is ¼ in. (6 mm).

12.5 Upon agreement between the manufacturer and purchaser, or at the manufacturer's option, for sizes 2 through 6 in., the spigot end of each conduit length shall have a circumferential ring mark, or depth of entry mark, placed at a distance from the conduit end equal to ¼ in. (6 mm) more than the depth of the socket of the integral bell or attached coupling supplied on the conduit.

### 13. Packaging

13.1 Conduit sweeps and bends shall be packaged to protect them during shipment, handling, and subsequent storage.

13.2 Conduit shall be packaged in units not to exceed 5 ft in width, no less than 1 ft nor greater than 4 ft in height. Packaged units shall be capable of supporting no less than 10 ft in height of packaged units without damaging the packaged conduit. Packaged conduit units shall have provisions for fork lifting equipment.

13.3 Fittings and cement shall be packaged in suitable containers. Containers with volume greater than 30 ft<sup>3</sup> shall have provisions for fork lifting equipment.

### 14. Quality Assurance

14.1 When the product is marked with this designation, F 512, the manufacturer affirms that the product was manufactured, inspected, sampled, and tested in accordance with this specification and has been found to meet the requirements of this specification.

**TABLE 1 Conduit Dimensions and Tolerances, in.**

Nominal Size	Average Outside Diameter	Tolerance on		Minimum Wall Thickness <sup>A</sup>									
		Average	Out-of-Round <sup>B</sup>	Minimum Modulus 400 000 psi					Minimum Modulus 500 000 psi				
				EB-20	EB-35	DB-60	DB-100	DB-120	EB-20	EB-35	DB-60	DB-100	DB-120
1	1.315	±0.005	0.060	—	—	—	—	0.060	—	—	—	—	0.060
1½	1.900	±0.006	0.060	—	—	0.060	—	0.065	—	—	—	—	0.060
2	2.375	±0.006	0.060	—	0.060	0.065	—	0.083	0.060	—	0.060	—	0.077
3	3.500	±0.008	0.060	0.067	0.082	0.100	0.121	0.127	0.061	0.076	0.092	0.112	0.118
3½	4.000	±0.008	0.100	0.078	0.095	0.115	0.138	0.147	0.072	0.088	0.107	0.128	0.136
4	4.500	±0.009	0.100	0.089	0.109	0.131	0.155	0.166	0.082	0.100	0.121	0.145	0.154
5	5.563	±0.010	0.100	0.112	0.136	0.164	0.192	0.205	0.103	0.126	0.152	0.179	0.191
6	6.625	±0.011	0.100	0.135	0.164	0.196	0.229	0.244	0.125	0.152	0.182	0.213	0.227

<sup>A</sup> Tolerance on wall thickness is +12, -0 % or +0.030, -0.000 in. whichever is greater.

<sup>B</sup> "Out-of-round" is defined as maximum diameter minus minimum diameter.