



Standard Specification for Styrene-Rubber (SR) Plastic Drain Pipe and Fittings¹

This standard is issued under the fixed designation D 2852; the number immediately following the designation indicates the year of original adoption or, in the case of revision, the year of last revision. A number in parentheses indicates the year of last reapproval. A superscript epsilon (ϵ) indicates an editorial change since the last revision or reapproval.

This standard has been approved for use by agencies of the Department of Defense.

1. Scope

1.1 This specification covers requirements and test methods for materials, dimensions, workmanship, impact resistance, load-deflection properties, dimensional stability, and joint tightness of plain-end or bell-end styrene-rubber (SR) plastic drain pipe and fittings in sizes 2 through 6 in.

1.2 The values stated in inch-pound units are to be regarded as the standard. The values given in parentheses are for information only.

1.3 The following safety hazards caveat pertains only to the test methods portion, Section 8, of this specification: *This standard does not purport to address all of the safety problems, if any, associated with its use. It is the responsibility of the user of this standard to establish appropriate safety and health practices and determine the applicability of regulatory limitations prior to use.*

2. Referenced Documents

2.1 ASTM Standards:

- D 256 Test Methods for Impact Resistance of Plastics and Electrical Insulating Materials²
- D 618 Practice for Conditioning Plastics and Electrical Insulating Materials for Testing²
- D 638 Test Method for Tensile Properties of Plastics²
- D 648 Test Method for Deflection Temperature of Plastics Under Flexural Load²
- D 1600 Terminology for Abbreviated Terms Relating to Plastics^{2,3}
- D 2122 Test Method for Determining Dimensions of Thermoplastic Pipe and Fittings³
- D 2321 Practice for Underground Installation of Flexible Thermoplastic Sewer Pipe³
- D 2412 Test Method for Determination of External Loading Characteristics of Plastic Pipe by Parallel-Plate Loading³
- D 2444 Test Method for Impact Resistance of Thermoplastic Pipe and Fittings by Means of a Tup (Falling Weight)³

D 3122 Specification for Solvent Cements for Styrene-Rubber Plastic Pipe and Fittings³

F 412 Terminology Relating to Plastic Piping Systems³

2.2 Federal Standard:

Fed. Std. No. 123 Marking for Shipment (Civil Agencies)⁴

2.3 Military Standard:

MIL-STD-129 Marking for Shipment and Storage⁴

3. Terminology

3.1 *Definitions*—Definitions are in accordance with Terminology F 412, and abbreviations are in accordance with Terminology D 1600, unless otherwise specified. The abbreviation for styrene-rubber plastics is SR.

4. Significance and Use

4.1 The requirements for this specification are intended to provide pipe and fittings suitable for nonpressure underground drainage of sewage and certain other liquid wastes, in applications outside the building limits, where dimensional stability, resistance to aging, and strong eight joints are required. The plastic drain pipe and fittings described in this specification are intended for use in the following applications:

- 4.1.1 House connections to septic tanks.
- 4.1.2 Footing drains (foundation drains).
- 4.1.3 Storm drainage.

4.2 The pipe should be installed in accordance with Practice D 2321.

5. Materials and Manufacture

5.1 *Materials*—The pipe and fittings shall be made of styrene-rubber (SR) plastics meeting the following requirements:

5.1.1 The SR plastics compound shall contain at least 50 % styrene plastics, combined with rubbers to a minimum rubber content of 5 %, and compounding materials such as antioxidants and lubricants, and may contain up to 15 % acrylonitrile combined in the styrene plastics or rubbers, or both. The rubbers shall be of the polybutadiene or butadiene-styrene type, or both, with a maximum styrene content of 25 % or nitrile type. The combined styrene plastics and rubber content

¹ This specification is under the jurisdiction of ASTM Committee F-17 on Plastic Piping Systems and is the direct responsibility of Subcommittee F17.65 on Land Drainage.

Current edition approved Sept. 10, 1995. Published November 1995. Originally published as D 2852 – 69 T. Last previous edition D 2852 – 93.

² *Annual Book of ASTM Standards*, Vol 08.01.

³ *Annual Book of ASTM Standards*, Vol 08.04.

⁴ Available from Standardization Documents Order Desk, Bldg. 4 Section D, 700 Robbins Ave., Philadelphia, PA 19111-5094, Attn: NPODS.

shall be not less than 90 %. No fillers may be used.

5.1.2 The SR plastic compound shall meet the following minimum requirements when tested in accordance with Section 8:

Tensile strength at rupture,	3800 psi (26.2 MPa)
Elongation at rupture, %,	15
Modulus of elasticity in tension,	300 000 psi (2068 MPa)
Izod impact strength, notched	0.8 ft-lbf/in. (42.5 J/m)
Deflection temperature at 264 psi (1.82 MPa), ° F (°C)	149 (65)

5.1.3 *Rework Material*—Clean rework material, generated from the manufacturer’s own pipe or fittings production, may be used by the same manufacturer, provided that the pipe and fittings produced meet all of the requirements of this specification.

6. Workmanship, Finish, and Appearance

6.1 *Workmanship*—The pipe shall be homogeneous throughout and essentially uniform in color, opacity, density, and other properties. The inside and outside surfaces shall be semimatte or glossy in appearance and free of chalking, sticky, or tacky material. The pipe walls shall be free of cracks, holes, blisters, voids, foreign inclusion, or other defects that are visible to the naked eye and that may affect the wall integrity. Holes deliberately placed in perforated pipe are acceptable. The surfaces shall be free of excessive bloom. Bloom or chalking may develop in pipe exposed to direct rays of the sun (ultraviolet radiant energy) for extended periods and consequently these requirements do not apply to pipe after extended exposure to direct rays of the sun.

6.2 Pipe Dimensions:

6.2.1 *Pipe Diameters*—The outside and inside diameters of the pipe shall be within the tolerances given in Table 1 when tested in accordance with 8.6.1.

6.2.2 *Wall Thickness*—Pipe wall thickness shall meet the requirements of Table 1 when measured in accordance with 8.6.2.

6.2.3 *Laying Length*—The laying length shall be 10 ft with a tolerance of $-0 + \frac{1}{2}$ in., unless otherwise specified. The laying length shall be determined in accordance with 8.6.3.

6.3 Fitting and Bell-End Dimensions:

6.3.1 *Socket Diameters*—The inside diameters of the sockets shall comply with the dimensions in Table 2 when determined in accordance with 8.7.1.

6.3.2 Wall Thickness:

6.3.2.1 For belled pipe and fittings fabricated from pipe sections, the thickness of the belled section shall be considered satisfactory if the bell was formed from pipe meeting the requirements of Table 1.

6.3.2.2 For molded fittings, the wall thickness of the waterway and socket or bell shall be no less than the respective minimum thickness listed for the equivalent pipe wall in Table 2. For reducing fittings or those with smaller inlets, the minimum wall thickness of each inlet shall be no less than the minimum wall thickness for that size pipe.

6.3.3 *Socket Depth*—The socket depth shall be not less than that shown in Table 2 when measured in accordance with 8.7.3.

6.3.4 *Laying Length*—The laying length shall meet the requirements shown in Table 3. All dimensions are minimum with a negative tolerance of zero.

6.4 *Impact Strength*—The impact strength of the pipe and fittings shall not be less than the values given in Table 4 when tested in accordance with 8.9.

NOTE 1—This test is intended only as a quality control test, not as a simulated service test.

6.5 *Pipe Stiffness*—The pipe stiffness at 5 % deflection shall be not less than the values given in Table 5 when tested in accordance with 8.10. This requirement does not apply to fittings.

NOTE 2—The 5 % deflection criterion, which was arbitrarily selected for testing convenience, should not be considered as a limitation with respect to in-use deflection. The engineer is responsible for establishing the acceptable deflection limit.

NOTE 3—The strength and load-carrying capabilities of plastic drain and sewer pipe are measured and reported as Pipe Stiffness, which is determined in accordance with Test Method D 2412. The term “crush strength” is not applicable to plastic piping because (a) the values obtained can be significantly different, depending on the bedding, loading, or testing technique used; and (b) the term derives from rigid pipe and refers to its ultimate strength at rupture.

6.6 *Flattening*—The pipe shall show no evidence of splitting, cracking, or breaking at 20 % deflection when tested in accordance with 8.8.

6.7 *Dimensional Stability*—The average decrease in inside diameter of pipe and fittings shall not exceed 10 % when tested in accordance with 8.11.

6.8 *Solvent Cement*—Solvent cements shall meet the requirements of Specification D 3122.

6.9 *Joint Tightness*—Joints made with pipe and fittings shall not leak when tested in accordance with 8.12.

7. Retest and Rejection

7.1 If the results of any test(s) do not meet the requirements of this specification, the test(s) may be conducted again in accordance with an agreement between the purchaser and the seller. There shall be no agreement to lower the minimum requirement of the specification by such means as omitting

TABLE 1 Dimensions and Tolerances for SR Plastic Drain Pipe, in. (mm)

Nominal Size	Average Outside Diameter	Permissible Deviations of the Diameter from Measured Average (Out-of-roundness)	Minimum Average Inside Diameter	Minimum Wall Thickness
2	2.250 ± 0.006 (57.2 ± 0.15)	±0.030 (±0.76)	2.000 (50.8)	0.073 (1.85)
3	3.250 ± 0.008 (82.6 ± 0.20)	±0.040 (±1.02)	2.875 (73.0)	0.100 (2.54)
4	4.215 ± 0.009 (104.8 ± 0.23)	±0.050 (±1.27)	3.875 (98.4)	0.125 (3.18)
5	5.300 ± 0.010 (134.6 ± 0.25)	±0.060 (±1.52)	4.875 (123.8)	0.150 (3.81)
6	6.275 ± 0.011 (159.4 ± 0.28)	±0.070 (±1.78)	5.875 (149.2)	0.180 (4.57)

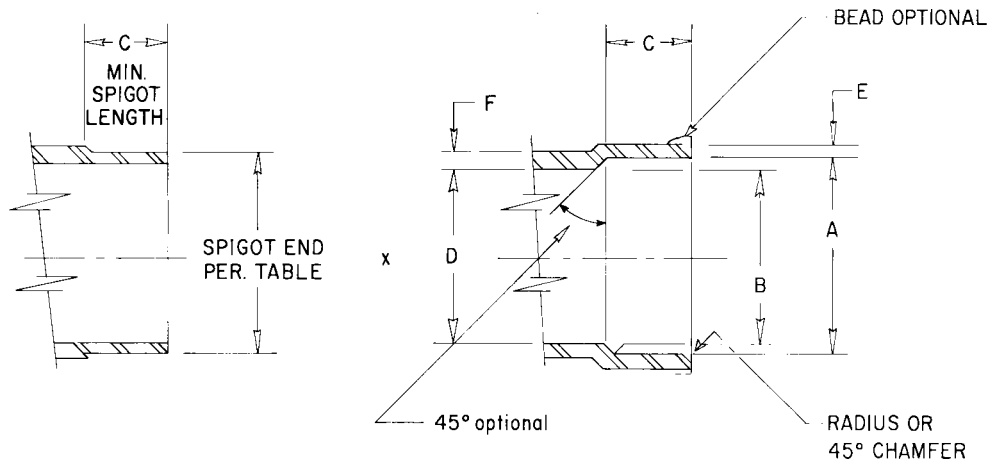

TABLE 2 Fitting Dimensions and Tolerances, in. (mm)

Nominal Size	A	B	C, min	D, min	E and F, min ^A
2	2.264 ± 0.006 (57.5 ± 0.15)	2.245 ± 0.006 (57.0 ± 0.15)	3/4(19.1)	2 (50.8)	0.073 (1.85)
3	3.271 ± 0.008 (83.1 ± 0.20)	3.245 ± 0.008 (82.4 ± 0.20)	1 1/2(38.1)	2 7/8 (73.0)	0.100 (2.54)
4	4.235 ± 0.009 (107.6 ± 0.23)	4.210 ± 0.009 (106.9 ± 0.23)	1 3/4 (44.5)	3 7/8 (98.4)	0.125 (3.18)
5	5.330 ± 0.010 (135.4 ± 0.25)	5.295 ± 0.010 (134.5 ± 0.25)	2 (50.8)	4 7/8 (123.8)	0.150 (3.81)
6	6.305 ± 0.011 (160.1 ± 0.28)	6.270 ± 0.011 (159.3 ± 0.28)	2 1/2 (63.5)	5 7/8 (149.2)	0.180 (4.57)

^AFitting Wall Thickness—The wall thickness is a minimum value except that a ±10% variation resulting from core shift is allowable. In such a case, the average of two opposite wall thicknesses shall equal or exceed the value shown in the table.

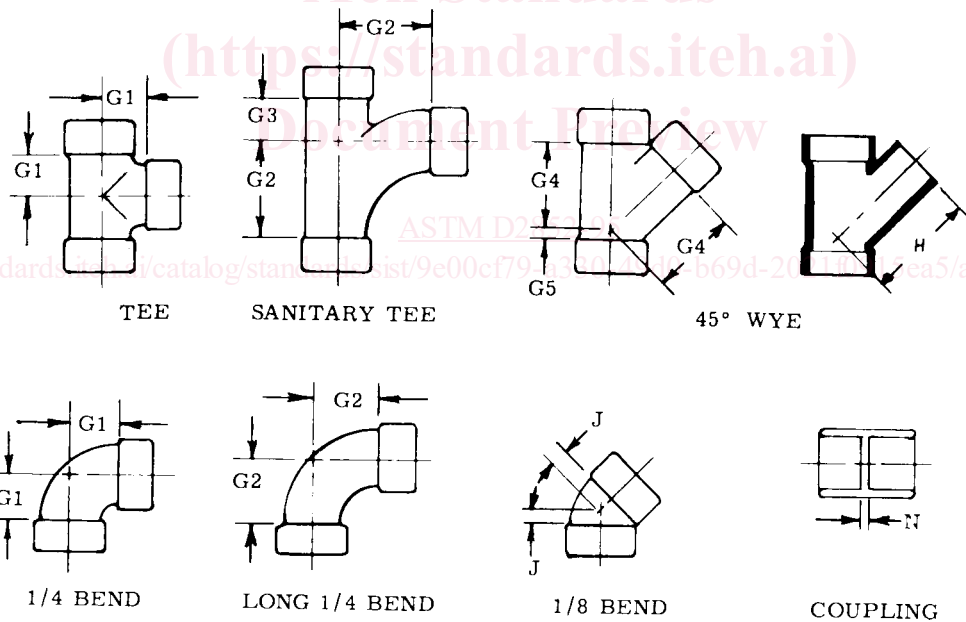

TABLE 3 Fitting Minimum Laying Length Dimensions, in. (mm)

Size	G1	G2	G3	G4	G5	H	J	N
2	1 5/32 (29.4)	1 3/4 (31.8)	1 5/16 (23.8)	2 3/4 (57.2)	1/2 (12.7)	3 7/8 (98.4)	9/16 (14.3)	3/32 (2.4)
3	1 21/32 (42.1)	2 7/8 (73.0)	1 3/8 (34.9)	3 1/4 (82.6)	9/16 (14.3)	6 (152.4)	1 1/16 (17.5)	1/8 (3.2)
4	2 5/32 (54.8)	3 1 1/16 (93.7)	1 3/4 (93.7)	5 (127.0)	1 5/16 (23.8)	7 1/16 (188.9)	7/8 (22.2)	1/8 (3.2)
5	2 11/16 (68.3)	—	—	—	—	—	—	1/8 (3.2)
6	3 3/16 (81.0)	—	—	7 7/8 (200.0)	1 5/16 (33.3)	—	1 3/8 (34.9)	1/8 (3.2)

tests that are a part of the specification, substituting or modifying a test method, or by changing the specification limits. In retesting, the product requirements of this specification shall be met and the test methods designated in the

specification shall be followed. If, upon retest, failure occurs, the quantity of product represented by the test(s) does not meet the requirements of this specification.