

JTC 1

INTERNATIONAL STANDARD

ISO/IEC
10173

First edition
1991-08-15

Information technology — Integrated Services Digital Network (ISDN) primary access connector at reference points S and T

iTeh STANDARD PREVIEW
Technologies de l'Information — Connecteur d'accès primaire au RNIS
aux points de référence S et T
(standards.iteh.ai)

ISO/IEC 10173:1991

<https://standards.iteh.ai/catalog/standards/sist/94c55465-db52-4c28-ac34-f2eca4d06451/iso-iec-10173-1991>



Reference number
ISO/IEC 10173:1991(E)

Foreword

ISO (the International Organization for Standardization) and IEC (the International Electrotechnical Commission) form the specialized system for worldwide standardization. National bodies that are members of ISO or IEC participate in the development of International Standards through technical committees established by the respective organization to deal with particular fields of technical activity. ISO and IEC technical committees collaborate in fields of mutual interest. Other international organizations, governmental and non-governmental, in liaison with ISO and IEC, also take part in the work.

In the field of information technology, ISO and IEC have established a joint technical committee, ISO/IEC JTC 1. Draft International Standards adopted by the joint technical committee are circulated to national bodies for voting. Publication as an International Standard requires approval by at least 75 % of the national bodies casting a vote.

International Standard ISO/IEC 10173 was prepared by Joint Technical Committee ISO/IEC JTC 1, *Information technology*.

Annexes A, B and C of this International Standard are for information only.

ISO/IEC 10173:1991
<https://standards.iteh.ai/catalog/standards/sist/94c55465-db52-4c28-ae34-f2eca4d06451/iso-iec-10173-1991>

Information technology — Integrated Services Digital Network (ISDN) primary access connector at reference points S and T

1 Scope

This International Standard specifies the 8-contact connector (plug and jack) and the assignments of its contact numbers for use in the physical interfaces of Integrated Services Digital Network (ISDN) primary rate access services conforming to CCITT Recommendation I.431.

In this International Standard, as in CCITT Recommendation I.431, the term "NT" is used to indicate the network terminating layer 1 aspects of NT1s and NT2s, and the term "TE" is used to indicate terminal layer 1 aspects of TE1s, TAs and NT2s.

NOTES

1 This International Standard specifies only those connector dimensions required to ensure intermatability of plug and jack. Complete detailed specifications of the connector are the subject of IEC 603-7, see annex C.

2 CCITT recognizes an alternative connection system which is not covered by this International Standard. It uses coaxial connectors as specified in IEC 169-8 (see annex C), and illustrated in annex B.

2 Normative references

The following standards contain provisions which, through reference in this text, constitute provisions of this International Standard. At the time of publication, the editions indicated were valid. All standards are subject to revision, and parties to agreements based on this International Standard are encouraged to investigate the possibility of applying the most recent editions of the standards indicated below. Members of IEC and ISO maintain registers of currently valid International Standards.

ISO 8877:1987, *Information processing systems — Interface connector and contact assignments for ISDN basic access interface located at reference points S and T.*

CCITT Recommendation I.431:1988, *Primary rate user-network interface — Layer 1 specification.*

3 Definitions

For the purposes of this International Standard, the following definitions apply.

3.1 contact: The conductive element in a component which mates with the corresponding element to provide an electrical path.

3.2 plug: Free male connector.

3.3 jack: Fixed or free female connector.

4 Connector

The connector specified in this International Standard has the same basic dimensions as the connector specified in ISO 8877, but contains additional keying features to prevent inadvertent connection to services using that connector.

Jacks for use in ISDN primary rate access applications shall conform to the dimensions specified in figures 4 and 5. However, as a national option, the provision for keying the jack may be modified to permit the insertion of either the plug specified in ISO 8877 (ISDN basic access) or the plug specified in this International Standard.

Plugs and jacks with up to eight contacts are specified for the interconnection of TEs and NTs. Unless the TE is directly connected to the interface cable, one plug and jack pair shall be used to connect the TE connecting cord to the interface cable at interface point 1a as specified in CCITT Recommendation I.431 (see figures A.1 and B.1). Unless the NT is directly connected to the interface cable, a plug and jack pair shall be used to connect the NT connecting cord at interface point 1b. In some countries, where the NT is a multi-port device such as a PABX, a different connector (such as one that accommodates multiple interfaces) may be used at interface

point 1b. A typical arrangement of connecting cords and an interface cable is shown in figure A.1 of this International Standard.

TE and NT connecting cords shall be terminated in plugs as specified below. Figure 1 illustrates the cord-terminating plug, which may have four, six, or eight contacts. The number of physical contacts required is dependent on the use by the associated equipment, TE or NT, of optional powering provisions across the interface, and of optional provisions for shield continuity. The optional powering capabilities are described in CCITT Recommendation I.431, Section 8, and both the powering and shield continuity options are summarized in annex A of this International Standard.

Unless intended for direct connection to the TE or NT, interface cables shall be terminated in jacks as

specified below. Figure 2 illustrates the jack, which can have four, six, or eight contacts. As with the plug, the number of contacts required is dependent on the use of powering and shield continuity options.

Connector dimensions necessary to ensure mating of plugs with jacks (see note 1) are specified in figures 3 to 5. Figure 3 gives the mechanical specifications of the 8-contact plug, and figure 5 that of the jack. Figure 4 gives the plug/jack specification for mating.

Plugs for use in ISDN primary rate applications shall conform to the dimensions specified in these figures. Physical contacts 3, 6, 7, and 8 are shown for illustrative purposes and may be omitted from the connector assembly if not required.

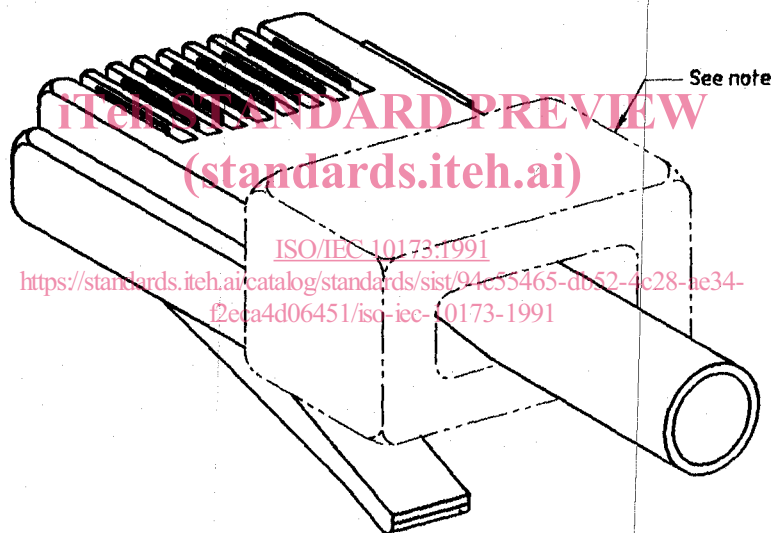

NOTE — This portion of the plug illustrates a structure necessary for securing the cordage and is not pertinent to proper mating with the jack.

Figure 1 — Plug, 8-pole

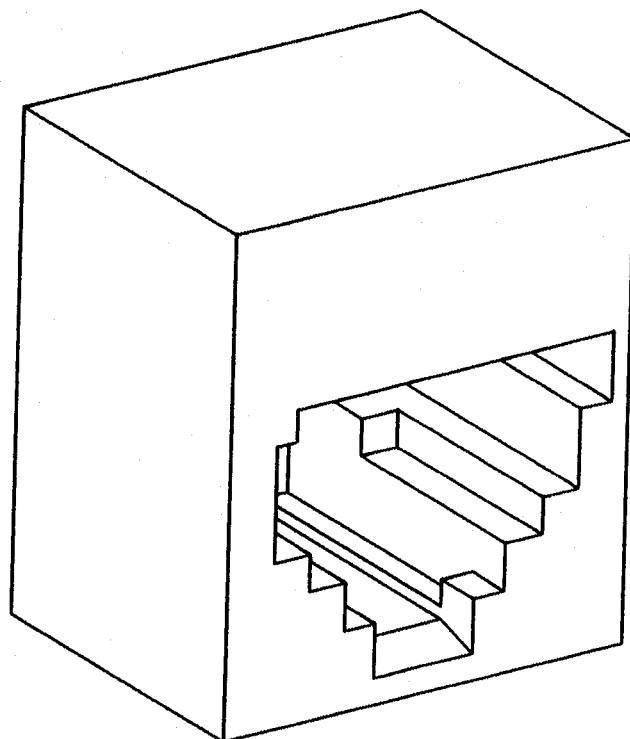

NOTE — Jack contacts not shown for clarity.

ITeH STANDARD PREVIEW
(standardsiteh.ai)

Figure 2 — Jack, 8-pole

ISO/IEC 10173:1991

<https://standards.iteh.ai/catalog/standards/sist/94c55465-db52-4c28-ae34-f2eca4d06451/iso-iec-10173-1991>

Dimensions in millimetres
(Inches in parentheses)

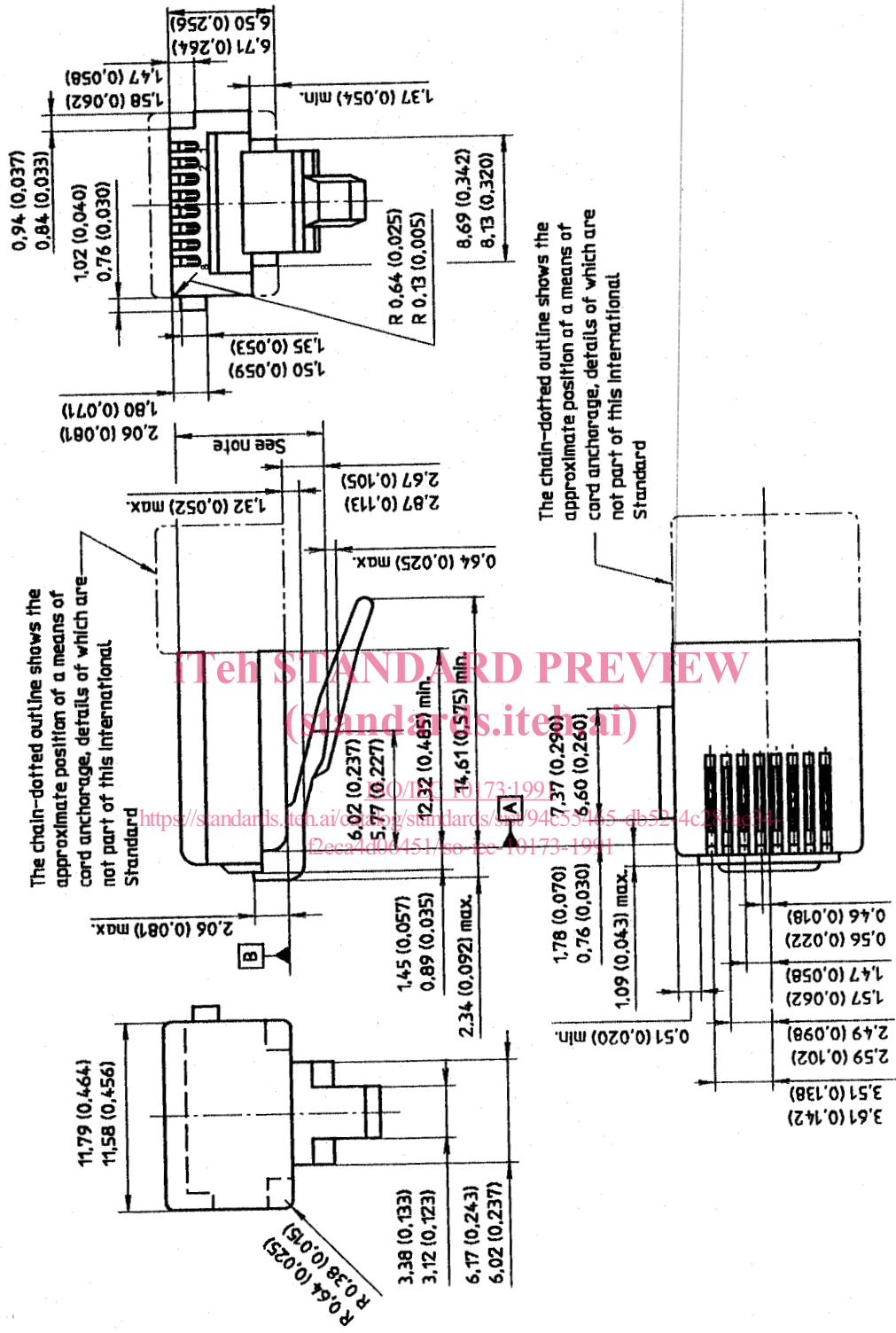

NOTES

- 1 With the latch depressed, this dimension shall be 8,36 (0,329) max.
- 2 Dimensions to be centrally located about the centreline within $\pm 0,08$ ($\pm 0,003$).

Figure 3 — Plug mechanical specification

Dimensions in millimetres
(inches in parentheses)

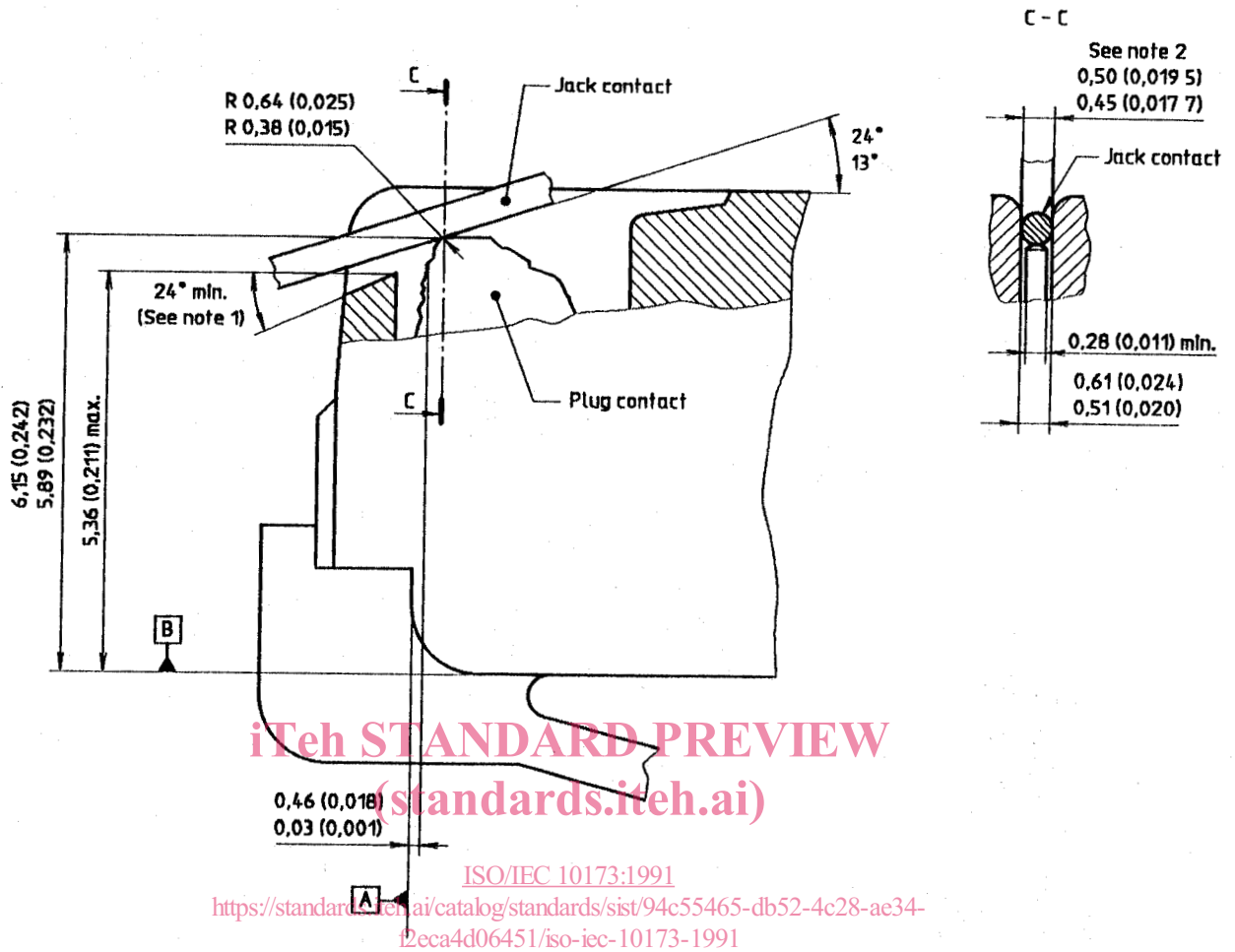

NOTES

- 1 The 24° min. angle applies only to plugs with front plastic walls higher than 4,83 (0,190).
- 2 Jack contacts may be rectangular with a width of 0,5 (0,019 5) max. and 0,36 (0,014) min.

Figure 4 — Plug/jack contact specification

Dimensions in millimetres
(Inches in parentheses)

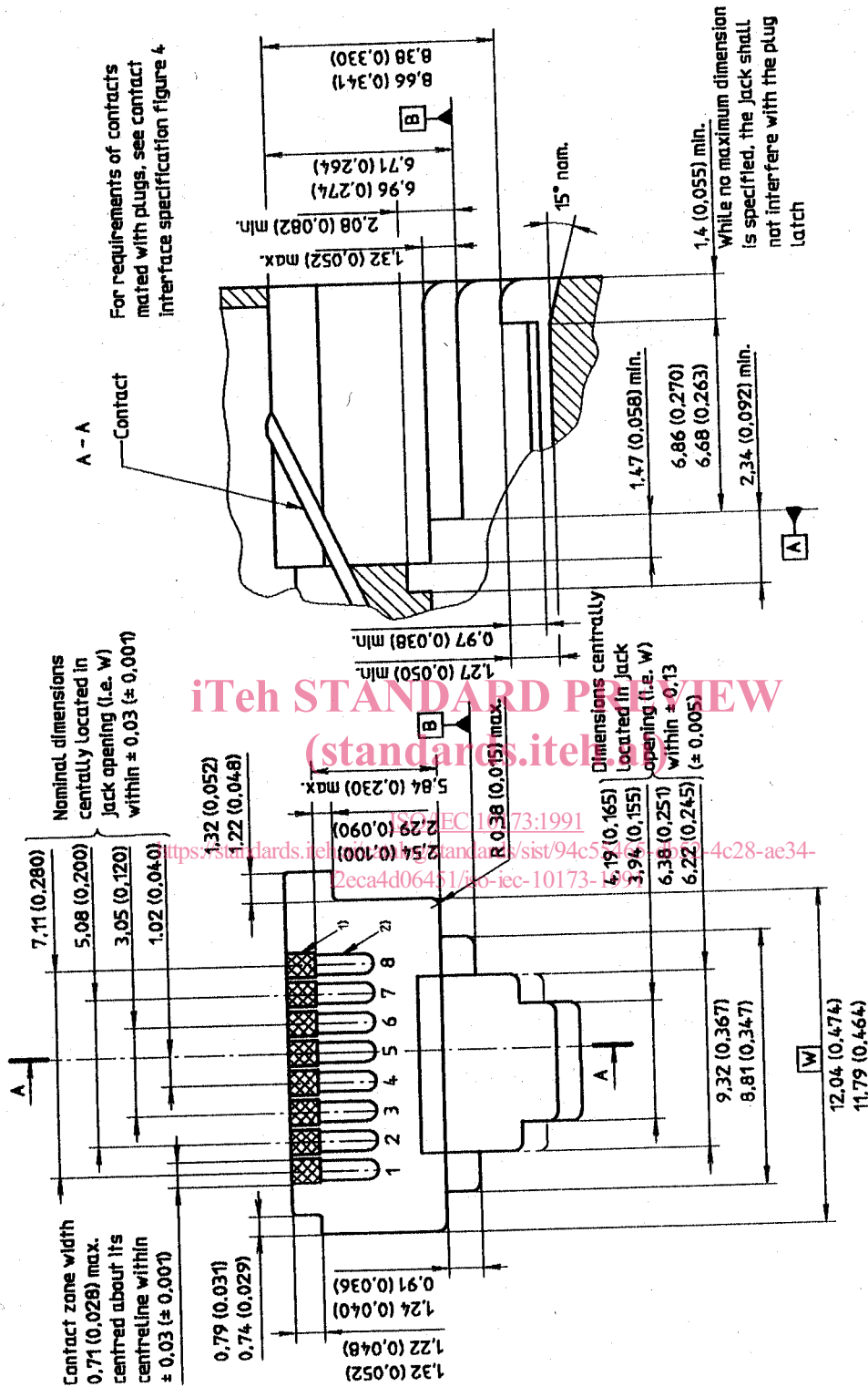

1) CONTACT ZONE - Contacts shall be completely within their individual contact zone to ensure proper mating as a plug is inserted.
2) Rear contact guide slots, see note.

NOTE - Guide slots shall prevent any individual contact from being displaced from its associated slot while permitting movement within individual slots.

Figure 5 - Jack mechanical specification

5 Assignment of contacts

Four contacts are assigned for the two conductor pairs for signal transmission NT to TE and TE to NT, two contacts each for TRANSMIT and RECEIVE. Contacts are also assigned for an optional pair used for powering, and for continuity of shields for individual pairs. The contact assignments applicable to the interface on the NT1 side of an NT2 shall be the same as for the interface at a TE. Where a shield to both pairs is provided, the two contacts may be used in parallel to provide continuity.

NOTE 3 This International Standard does not specify where shielding is required, but some information is given in A.3.

The use of twisted pairs for TRANSMIT and RECEIVE circuits shall conform to the applicable requirements of CCITT Recommendation I.431.

Table 1 — Contact assignments

Contact	TE	NT	Polarity
1	Receive	Transmit	
2	Receive	Transmit	
3	Shield (R) ¹⁾	Shield (T) ¹⁾	
4	Transmit	Receive	
5	Transmit	Receive	
6	Shield (T) ¹⁾	Shield (R) ¹⁾	
7	Power source ¹⁾	Power sink ¹⁾	—
8	Power source ¹⁾	Power sink ¹⁾	+

1) Optional, see A.2.

iTeh STANDARD PREVIEW (standards.iteh.ai)

ISO/IEC 10173:1991

<https://standards.iteh.ai/catalog/standards/sist/94c55465-db52-4c28-ac34-f2cca4d06451/iso-iec-10173-1991>