**Carbonaceous materials used in the
production of aluminium — Pitch for
electrodes — Determination of sulfur
content by an instrumental method**

*Produits carbonés utilisés pour la production de l'aluminium — Brai pour
électrodes — Dosage du soufre par une méthode instrumentale*

iTeh STANDARD PREVIEW
(standards.iteh.ai)

ISO 10238:1999

<https://standards.iteh.ai/catalog/standards/sist/c9938c70-2d11-42c8-aa32-1c1ad25eae3/iso-10238-1999>



PDF disclaimer

This PDF file may contain embedded typefaces. In accordance with Adobe's licensing policy, this file may be printed or viewed but shall not be edited unless the typefaces which are embedded are licensed to and installed on the computer performing the editing. In downloading this file, parties accept therein the responsibility of not infringing Adobe's licensing policy. The ISO Central Secretariat accepts no liability in this area.

Adobe is a trademark of Adobe Systems Incorporated.

Details of the software products used to create this PDF file can be found in the General Info relative to the file; the PDF-creation parameters were optimized for printing. Every care has been taken to ensure that the file is suitable for use by ISO member bodies. In the unlikely event that a problem relating to it is found, please inform the Central Secretariat at the address given below.

iTeh STANDARD PREVIEW
(standards.iteh.ai)

ISO 10238:1999

<https://standards.iteh.ai/catalog/standards/sist/c9938c70-2d11-42c8-aa32-1c1ad25eae3/iso-10238-1999>

© ISO 1999

All rights reserved. Unless otherwise specified, no part of this publication may be reproduced or utilized in any form or by any means, electronic or mechanical, including photocopying and microfilm, without permission in writing from either ISO at the address below or ISO's member body in the country of the requester.

ISO copyright office
Case postale 56 • CH-1211 Geneva 20
Tel. + 41 22 749 01 11
Fax + 41 22 734 10 79
E-mail copyright@iso.ch
Web www.iso.ch

Printed in Switzerland

Foreword

ISO (the International Organization for Standardization) is a worldwide federation of national standards bodies (ISO member bodies). The work of preparing International Standards is normally carried out through ISO technical committees. Each member body interested in a subject for which a technical committee has been established has the right to be represented on that committee. International organizations, governmental and non-governmental, in liaison with ISO, also take part in the work. ISO collaborates closely with the International Electrotechnical Commission (IEC) on all matters of electrotechnical standardization.

International Standards are drafted in accordance with the rules given in the ISO/IEC Directives, Part 3.

Draft International Standards adopted by the technical committees are circulated to the member bodies for voting. Publication as an International Standard requires approval by at least 75 % of the member bodies casting a vote.

Attention is drawn to the possibility that some of the elements of this International Standard may be the subject of patent rights. ISO shall not be held responsible for identifying any or all such patent rights.

International Standard ISO 10238 was prepared by Technical Committee ISO/TC 47, *Chemistry*, Subcommittee SC 7, *Aluminium oxide, cryolite, aluminium fluoride, sodium fluoride, carbonaceous products for the aluminium industry*.

iTeh STANDARD PREVIEW (standards.iteh.ai)

[ISO 10238:1999](https://standards.iteh.ai/catalog/standards/sist/c9938c70-2d11-42c8-aa32-1c1ad25eae3/iso-10238-1999)

<https://standards.iteh.ai/catalog/standards/sist/c9938c70-2d11-42c8-aa32-1c1ad25eae3/iso-10238-1999>

iTeh STANDARD PREVIEW
(standards.iteh.ai)

ISO 10238:1999

<https://standards.iteh.ai/catalog/standards/sist/c9938c70-2d11-42c8-aa32-1c1ad25eae3/iso-10238-1999>

Carbonaceous materials used in the production of aluminium — Pitch for electrodes — Determination of sulfur content by an instrumental method

1 Scope

This International Standard describes a method for determining the sulfur content of pitch used in the production of aluminium. The method is applicable to pitches of both coal tar and petroleum origin, provided that they contain between 0,1 % and 4,0 % by mass of sulfur.

2 Normative references

The following normative documents contain provisions which, through reference in this text, constitute provisions of this International Standard. For dated references, subsequent amendments to, or revisions of, any of these publications do not apply. However, parties to agreements based on this International Standard are encouraged to investigate the possibility of applying the most recent editions of the normative documents indicated below. For undated references, the latest edition of the normative document referred to applies. Members of ISO and IEC maintain registers of currently valid International Standards.

ISO 565, *Test sieves — Metal wire cloth, perforated metal plate and electroformed sheet — Nominal sizes of openings.*

<https://standards.iteh.ai/catalog/standards/sist/c9938c70-2d11-42c8-aa32-1c1ad25eae3/iso-10238-1999>

ISO 3696, *Water for analytical laboratory use — Specification and test methods.*

ISO 4793, *Laboratory sintered (fritted) filters — Porosity grading, classification and designation.*

ISO 6257, *Carbonaceous materials used in the production of aluminium — Pitch for electrodes — Sampling.*

3 Principle

A known mass of the sample is burned in a stream of oxygen at a temperature of 1 350 °C. The oxides of sulfur formed, together with any chlorine present, are absorbed in neutral hydrogen peroxide and determined volumetrically. A correction is made to take account of the chlorine content of the sample. Aluminium oxide is added to the sample to prevent the retention of sulfur in the ash.

4 Reagents

Unless otherwise specified, use reagents of analytical reagent grade and water conforming to grade 3 of ISO 3696.

4.1 Disodium tetraborate solution, $c(\frac{1}{2}\text{Na}_2\text{B}_4\text{O}_7 \cdot 10\text{H}_2\text{O}) = 0,025 \text{ mol/l}$.

4.2 Sulfuric acid solution, $c(\frac{1}{2}\text{H}_2\text{SO}_4) = 0,025 \text{ mol/l}$.

4.3 Hydrogen peroxide solution, consisting of 3 % by volume of H_2O_2 and 97 % by volume of water, neutralized with the disodium tetraborate solution (4.1) to the screened indicator (4.4).

4.4 Screened indicator, consisting of equal volumes of a) and b) prepared as follows and mixed immediately before use:

- a) 0,125 g of methyl red dissolved in 100 ml of 95 % by volume ethanol solution;
- b) 0,083 g of methylene blue dissolved in 100 ml of 95 % by volume ethanol solution.

Store in a dark glass bottle.

4.5 Mercury(II) oxycyanide solution, consisting of approximately 100 ml of water saturated with mercury(II) oxycyanide ($3\text{Hg}(\text{CN})_2 \cdot \text{HgO}$).

Agitate thoroughly, filter and neutralize the filtrate with the sulfuric acid solution (4.2) to the screened indicator. Store the solution in a dark glass bottle. Do not keep longer than 4 days.

WARNING — This compound and its solution are toxic and should be handled with appropriate care.

4.6 Aluminium oxide, finely divided, particle size approximately 0,1 mm.

4.7 Oxygen.

4.8 Sodium hydroxide on an inert base, preferably of coarse grading, for example 1,7 mm to 1,2 mm, and preferably of the self-indicating type.

5 Apparatus

iTeh STANDARD PREVIEW
(standards.iteh.ai)

Ordinary laboratory apparatus and the following.

5.1 Combustion furnace and absorption train, as shown in Figure 1, and consisting of the following.

5.1.1 Furnace, electrically heated, designed to carry a tube of 28,5 mm outside diameter and to heat it over a length of about 125 mm to give a temperature of 1 350 °C at the centre of the hot zone and a temperature distribution curve similar to that shown in Figure 2.

5.1.2 Combustion tube, of 22 mm internal diameter and 28,5 mm outside diameter and 0,65 m long, made of refractory aluminous porcelain that is not permeable to gases at 1 400 °C.

5.1.3 Combustion boat, of iron-free unglazed porcelain, 70 mm long, 12,5 mm wide and 10 mm deep, that does not blister, discolour or change in mass on heating at 1 350 °C in oxygen for 3 h.

5.1.4 Silica pusher, comprising a sealed tube or rod of silica, 6 mm in diameter and approximately 450 mm long, flattened at one end to form a disc of 12 mm diameter for pushing the combustion boat into the furnace.

The pusher passes loosely through a glass or metal T-piece, one end of which fits into the rubber stopper that closes the inlet end of the combustion tube, the other being sealed with a rubber sleeve through which the pusher slides (see Figure 1). Oxygen is admitted through the limb of the T-piece.

The pusher is marked in millimetres from the disc end for convenience in measuring how far the combustion boat is pushed into the combustion tube.

5.1.5 Hook, comprising a length of stiff nickel chromium wire with a hooked end, to extract the combustion boat from the furnace on to a piece of refractory tile.

5.1.6 Flowmeter, capable of measuring rates of flow of oxygen of up to 300 ml/min.

5.1.7 Pressure gauge, to measure the back pressure on the system, normally 0,5 kPa to 0,7 kPa.

5.1.8 Heat-resistant stopper, of acrylonitrile or chloroprene rubber, for attaching the absorption train to the combustion tube.

5.1.9 Silica adapter, comprising a translucent silica tube, 10 mm outside diameter and approximately 250 mm long, terminating at one end in a funnel of 20 mm outside diameter.

5.1.10 Purification train, comprising a tower containing sodium hydroxide on an inert base (see 4.8) for removing any oxides of sulfur from the oxygen supply.

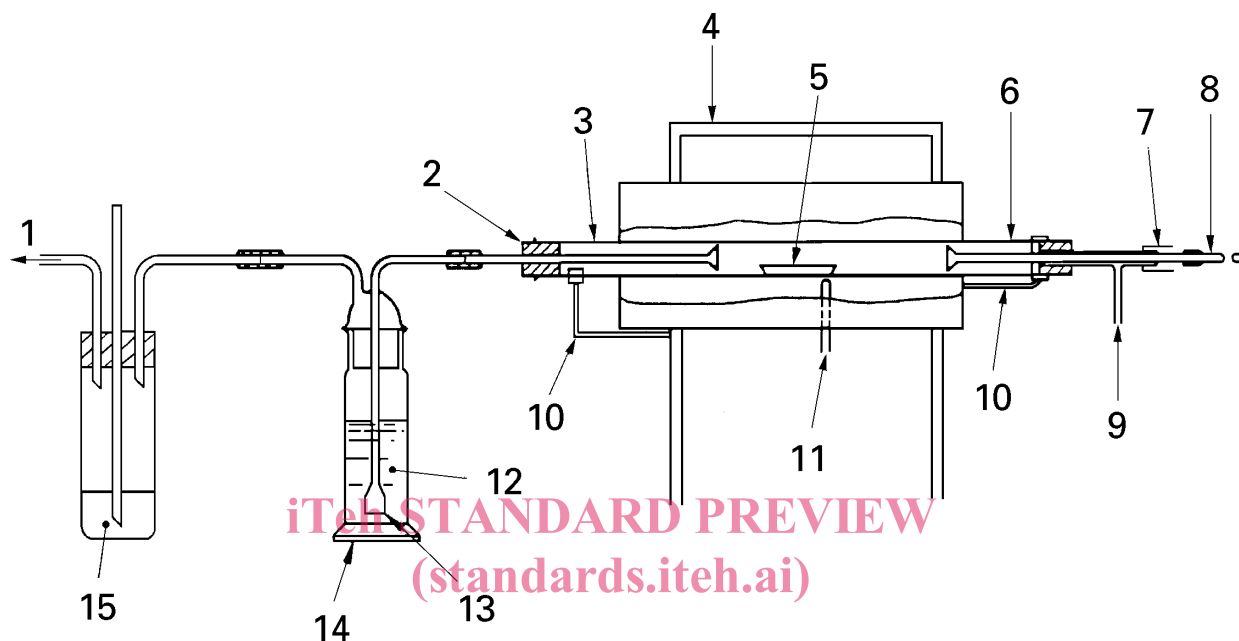

ITe STANDARD PREVIEW
(standards.iteh.ai)

ISO 10238:1999

<https://standards.iteh.ai/catalog/standards/sist/c9938c70-2d11-42c8-aa32-1c1ad25eae3/iso-10238-1999>

Key

1 To vacuum pump	6 Combustion tube	11 Thermocouple
2 Heat-resistant stopper	7 Rubber sleeve	12 Hydrogen peroxide solution
3 Silica adapter	8 Silica pusher	13 15 μm to 40 μm porosity grade P40 sintered disc
4 Furnace	9 Oxygen inlet	14 Gas washing bottle
5 Combustion boat	10 Tube support	15 Mercury

Figure 1 — Absorption train and furnace

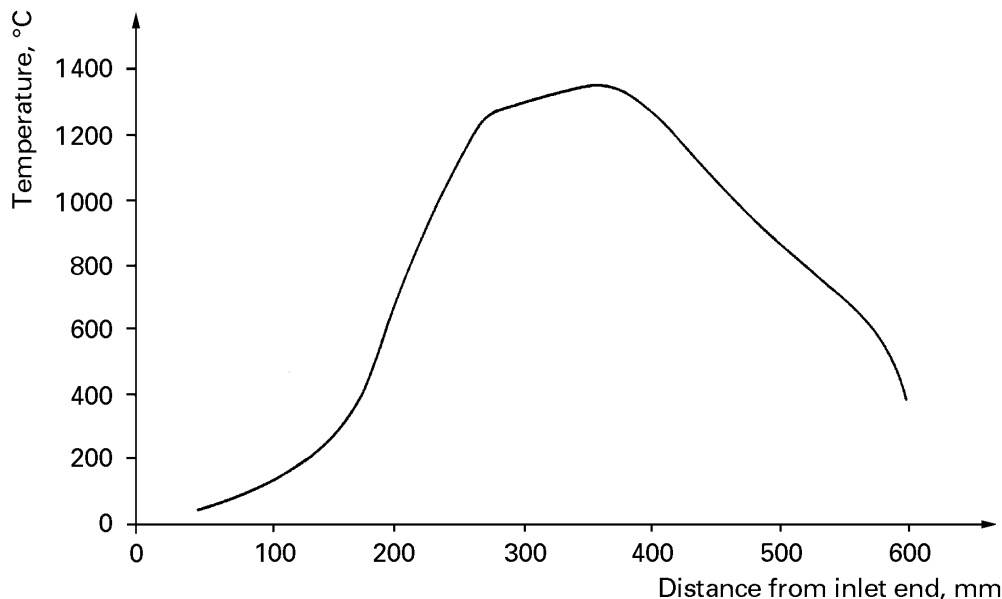

Figure 2 — Temperature distribution curve

5.1.11 Absorption vessel, comprising a gas washing tube or bottle with a sintered disc of porosity grade P40 conforming to the requirements of ISO 4793, of such a size that a 90 mm seal of liquid is obtained with 100 ml of liquid in the vessel.

5.1.12 Pressure regulator, comprising a bottle containing mercury, fitted with inlet and outlet tubes and a third tube capable of being moved up or down to regulate the suction on the system.

5.1.13 Vacuum pump, or other suitable pump.

6 Preparation of apparatus

Insert the combustion tube (5.1.2) into the furnace (5.1.1) so that it projects 100 mm at the exit end. Insert at this end the heat-resistant stopper (5.1.8) carrying the silica adapter (5.1.9) and adjust the latter so that the open end of the funnel is approximately 150 mm into the combustion tube. Insert the rubber stopper carrying the silica pusher (5.1.4) at the inlet end of the combustion tube and connect the oxygen supply through the purification train (5.1.10) to the limb of the T-piece.

7 Sampling and preparation of the test sample

7.1 Sampling

Sample the pitch in accordance with ISO 6257.

7.2 Preparation of test sample

Prepare the test sample immediately before the determination.

In the case of hard pitches, grind the sample so that it passes through a sieve of nominal aperture size 212 μm using a sieve conforming to the requirements of ISO 565.

If the pitch is too soft for grinding, melt and mix the sample in a covered vessel ensuring that its temperature does not exceed 150 °C and that the melting period does not exceed 10 min.

Take the material for the test portion from the molten sample.

8 Procedure

Raise the temperature of the furnace (5.1.1) to 1 350 °C and pass the oxygen (4.7) through the combustion tube (5.1.2). Weigh about 0,5 g of the test sample (7.2) to the nearest 0,1 mg, spread uniformly in the combustion boat (5.1.3) and cover with 0,5 g of the aluminium oxide (4.6). Measure 100 ml of the hydrogen peroxide solution (4.3) to the nearest 1 ml into the absorption vessel (5.1.11) and assemble the apparatus. Adjust the rate of gas flow by means of the vacuum pump (5.1.13) and the depth of seal in the pressure regulator (5.1.12) to maintain a slight suction in the combustion tube with oxygen entering at 300 ml/min as shown on the flowmeter (5.1.6).

Remove the rubber stopper carrying the silica pusher and insert the charged combustion boat into the combustion tube to a position such that its centre is 240 mm from the centre of the hottest zone. With the silica pusher fully withdrawn, replace the rubber stopper and continue to pass oxygen at 300 ml/min. At the end of each of the next 12 one-minute periods, push the combustion boat forward 20 mm, withdrawing the silica pusher each time, if necessary, to prevent its distortion. Allow the combustion boat to remain in the hottest zone for a further 4 min. Alternatively, continuous mechanical pushing of the combustion boat may be used provided that the heating schedule specified is maintained. Disconnect the absorption vessel and remove the silica adapter. Withdraw the combustion boat on to a refractory tile using the hook (5.1.5).

NOTE 1 If the sample combusts too quickly for the gases to be absorbed by the washer bottle, the combustion boat should be pushed forward 10 mm at the end of each of 24 one-minute periods.

Wash the silica adapter with water, collecting the washings in a 250 ml flask. Transfer the contents of the absorption vessel to the flask, washing the vessel with water and collecting the washings in the same flask.

NOTE 2 The total bulk of liquid should not exceed 150 ml.

Add two or three drops of the screened indicator (4.4) and titrate with the disodium tetraborate solution (4.1), using a suitable burette, to the neutral steel-grey colour. Add 10 ml of the mercury(II) oxycyanide solution (4.5) (sufficient excess for pitches containing up to 0,5 % chlorine) and titrate with the sulfuric acid solution (4.2) using a suitable burette to the neutral steel-grey colour.

NOTE 3 Titration against a white background is strongly recommended.

9 Determination of the blank

Carry out a blank determination under the same conditions as the actual determination but omitting the sample.

10 Calculation of result

Calculate the sulfur content, w_S , expressed as a percentage by mass using the equation:

$$w_S = \frac{0,0401}{m} [V_1 - V_2 - (V_3 - V_4)]$$

where

m is the mass, in grams, of sample taken;

V_1 is the volume, in millilitres, of disodium tetraborate solution (4.1) used in the determination;