

INTERNATIONAL STANDARD

ISO
10242-2

First edition
1991-12-01

Tools for pressing — Punch holder shanks —

Part 2:
Type C

iTeh STANDARD PREVIEW
(standards.iteh.ai)

Outillage de presse — Nez de presse —

Partie 2: Type C

[ISO 10242-2:1991](https://standards.iteh.ai/catalog/standards/sist/c92f6c24-aaf5-4b19-b671-e2e9544a6026/iso-10242-2:1991)

<https://standards.iteh.ai/catalog/standards/sist/c92f6c24-aaf5-4b19-b671-e2e9544a6026/iso-10242-2-1991>



Reference number
ISO 10242-2:1991(E)

Foreword

ISO (the International Organization for Standardization) is a worldwide federation of national standards bodies (ISO member bodies). The work of preparing International Standards is normally carried out through ISO technical committees. Each member body interested in a subject for which a technical committee has been established has the right to be represented on that committee. International organizations, governmental and non-governmental, in liaison with ISO, also take part in the work. ISO collaborates closely with the International Electrotechnical Commission (IEC) on all matters of electrotechnical standardization.

Draft International Standards adopted by the technical committees are circulated to the member bodies for voting. Publication as an International Standard requires approval by at least 75 % of the member bodies casting a vote.

International Standard ISO 10242-2 was prepared by Technical Committee ISO/TC 29, *Small tools*, Sub-Committee SC 8, *Tools for pressing and moulding*.

ISO 10242 consists of the following parts, under the general title *Tools for pressing — Punch holder shanks*:

- Part 1: Types A and B
- Part 2: Type C
- Part 3: Type D

Annex A of this part of ISO 10242 is for information only.

Tools for pressing — Punch holder shanks —

Part 2: Type C

1 Scope

This part of ISO 10242 specifies the interchangeability dimensions and tolerances, in millimetres, of punch holder shanks type C, intended for use in press tools.

It gives guidance on the materials, and specifies the hardness and designation of punch holder shanks in accordance with this part of ISO 10242.

2 Dimensions

See figure 1 and table 1.

3 Material and corresponding hardness

The material is left to the manufacturer's discretion and the hardness shall be at least 140 HB.

4 Designation

A punch holder shank in accordance with this part of ISO 10242 shall be designated by

- a) "Punch holder shank";
- b) reference to this part of ISO 10242;
- c) its type;
- d) its body diameter, D_1 , in millimetres.

EXAMPLE

A punch holder shank of type C and of body diameter $D_1 = 20$ mm is designated as follows:

Punch holder shank ISO 10242-2 C-20

Surface roughness values in micrometres

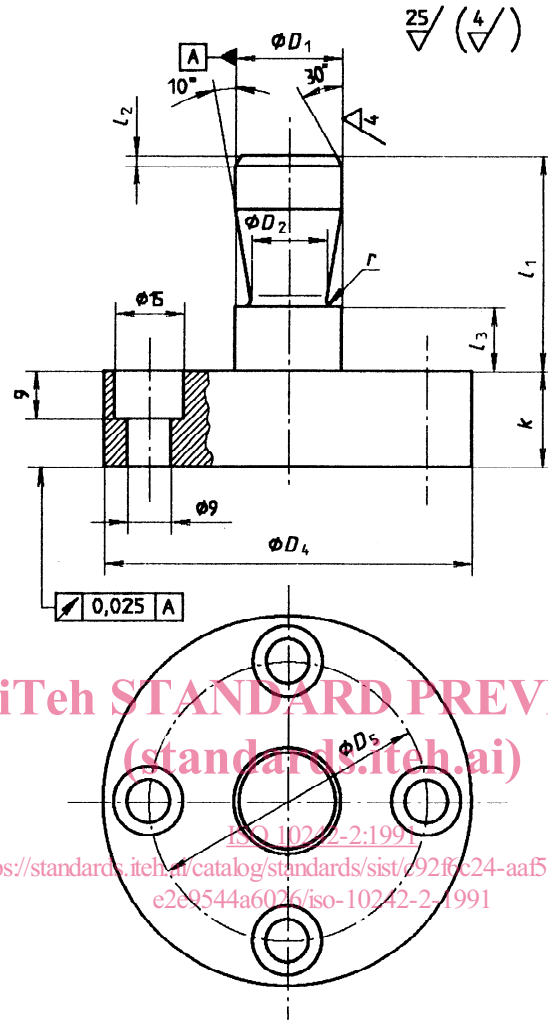

iTeh STANDARD PREVIEW
(standard.itteh.ai)

ISO 10242-2:1991
<https://standards.itteh.ai/catalog/standards/sist/92f6e24-aaf5-4b19-b671-e2e9544a6026/iso-10242-2-1991>

Figure 1

Table 1

D_1 19	D_2	D_4	D_5	k	l_1	l_2	l_3	r
20	15	67	50	18	40	2	12	2,5
25	20	82	65	18	45	2,5	16	2,5
32	25	97	80	23	56	3	16	2,5
40	32	122	105	23	70	4	26	4

Annex A
(informative)

Bibliography

[1] ISO 6506:1981, *Metallic materials — Hardness test — Brinell test.*

iTeh STANDARD PREVIEW
(standards.iteh.ai)

[ISO 10242-2:1991](https://standards.iteh.ai/catalog/standards/sist/c92f6c24-aaf5-4b19-b671-e2e9544a6026/iso-10242-2-1991)

<https://standards.iteh.ai/catalog/standards/sist/c92f6c24-aaf5-4b19-b671-e2e9544a6026/iso-10242-2-1991>

iTeh STANDARD PREVIEW
(standards.iteh.ai)

This page intentionally left blank

[ISO 10242-2:1991](#)

<https://standards.iteh.ai/catalog/standards/sist/c92f6c24-aaf5-4b19-b671-e2e9544a6026/iso-10242-2-1991>

iTeh STANDARD PREVIEW
(standards.iteh.ai)

This page intentionally left blank

[ISO 10242-2:1991](#)

<https://standards.iteh.ai/catalog/standards/sist/c92f6c24-aaf5-4b19-b671-e2e9544a6026/iso-10242-2-1991>

iTeh STANDARD PREVIEW
(standards.iteh.ai)

ISO 10242-2:1991

<https://standards.iteh.ai/catalog/standards/sist/c92f6c24-aaf5-4b19-b671-e2e9544a6026/iso-10242-2-1991>

UDC 621.979.07

Descriptors: presses, tools, punch holders, shanks, specifications, dimensions, designation.

Price based on 3 pages
