

# INTERNATIONAL STANDARD

# NORME INTERNATIONALE

**Arc welding equipment –**  
**Part 12: Coupling devices for welding cables**  
**(standards.iteh.ai)**

**Matériel de soudage à l'arc –**  
**Partie 12 : Dispositifs de connexion pour câbles de soudage**  
**IEC 60974-12:2011**  
**https://standards.iteh.ai/catalog/standards/sist/1260da4-3191-4d9c-b93d-a5aaf9a80c82/iec-60974-12-2011**



## THIS PUBLICATION IS COPYRIGHT PROTECTED

Copyright © 2011 IEC, Geneva, Switzerland

All rights reserved. Unless otherwise specified, no part of this publication may be reproduced or utilized in any form or by any means, electronic or mechanical, including photocopying and microfilm, without permission in writing from either IEC or IEC's member National Committee in the country of the requester.

If you have any questions about IEC copyright or have an enquiry about obtaining additional rights to this publication, please contact the address below or your local IEC member National Committee for further information.

Droits de reproduction réservés. Sauf indication contraire, aucune partie de cette publication ne peut être reproduite ni utilisée sous quelque forme que ce soit et par aucun procédé, électronique ou mécanique, y compris la photocopie et les microfilms, sans l'accord écrit de la CEI ou du Comité national de la CEI du pays du demandeur.

Si vous avez des questions sur le copyright de la CEI ou si vous désirez obtenir des droits supplémentaires sur cette publication, utilisez les coordonnées ci-après ou contactez le Comité national de la CEI de votre pays de résidence.

IEC Central Office  
3, rue de Varembe  
CH-1211 Geneva 20  
Switzerland  
Email: [inmail@iec.ch](mailto:inmail@iec.ch)  
Web: [www.iec.ch](http://www.iec.ch)

### About the IEC

The International Electrotechnical Commission (IEC) is the leading global organization that prepares and publishes International Standards for all electrical, electronic and related technologies.

### About IEC publications

The technical content of IEC publications is kept under constant review by the IEC. Please make sure that you have the latest edition, a corrigenda or an amendment might have been published.

- Catalogue of IEC publications: [www.iec.ch/searchpub](http://www.iec.ch/searchpub)

The IEC on-line Catalogue enables you to search by a variety of criteria (reference number, text, technical committee,...). It also gives information on projects, withdrawn and replaced publications.

- IEC Just Published: [www.iec.ch/online\\_news/justpub](http://www.iec.ch/online_news/justpub)

Stay up to date on all new IEC publications. Just Published details twice a month all new publications released. Available on-line and also by email.

[www.iec.ch/online\\_news/justpub](http://www.iec.ch/online_news/justpub)

- Electropedia: [www.electropedia.org](http://www.electropedia.org)

The world's leading online dictionary of electronic and electrical terms containing more than 20 000 terms and definitions in English and French, with equivalent terms in additional languages. Also known as the International Electrotechnical Vocabulary online.

- Customer Service Centre: [www.iec.ch/webstore/custserv](http://www.iec.ch/webstore/custserv)

If you wish to give us your feedback on this publication or need further assistance, please visit the Customer Service Centre FAQ or contact us:

Email: [csc@iec.ch](mailto:csc@iec.ch)

Tel.: +41 22 919 02 11

Fax: +41 22 919 03 00

### A propos de la CEI

La Commission Electrotechnique Internationale (CEI) est la première organisation mondiale qui élabore et publie des normes internationales pour tout ce qui a trait à l'électricité, à l'électronique et aux technologies apparentées.

### A propos des publications CEI

Le contenu technique des publications de la CEI est constamment revu. Veuillez vous assurer que vous possédez l'édition la plus récente, un corrigendum ou amendement peut avoir été publié.

- Catalogue des publications de la CEI: [www.iec.ch/searchpub/cur\\_fut-f.htm](http://www.iec.ch/searchpub/cur_fut-f.htm)

Le Catalogue en-ligne de la CEI vous permet d'effectuer des recherches en utilisant différents critères (numéro de référence, texte, comité d'études,...). Il donne aussi des informations sur les projets et les publications retirées ou remplacées.

- Just Published CEI: [www.iec.ch/online\\_news/justpub](http://www.iec.ch/online_news/justpub)

Restez informé sur les nouvelles publications de la CEI. Just Published détaille deux fois par mois les nouvelles publications parues. Disponible en-ligne et aussi par email.

- Electropedia: [www.electropedia.org](http://www.electropedia.org)

Le premier dictionnaire en ligne au monde de termes électroniques et électriques. Il contient plus de 20 000 termes et définitions en anglais et en français, ainsi que les termes équivalents dans les langues additionnelles. Egalement appelé Vocabulaire Electrotechnique International en ligne.

- Service Clients: [www.iec.ch/webstore/custserv/custserv\\_entry-f.htm](http://www.iec.ch/webstore/custserv/custserv_entry-f.htm)

Si vous désirez nous donner des commentaires sur cette publication ou si vous avez des questions, visitez le FAQ du Service clients ou contactez-nous:

Email: [csc@iec.ch](mailto:csc@iec.ch)

Tél.: +41 22 919 02 11

Fax: +41 22 919 03 00



IEC 60974-12

Edition 3.0 2011-05

# INTERNATIONAL STANDARD

## NORME INTERNATIONALE

**Arc welding equipment –**  
**Part 12: Coupling devices for welding cables**  
**STANDARD PREVIEW**  
**(standards.iteh.ai)**

**Matériel de soudage à l'arc –**  
**Partie 12 : Dispositifs de connexion pour câbles de soudage**  
IEC 60974-12:2011  
a5aa19a80c82/iec-60974-12-2011

INTERNATIONAL  
ELECTROTECHNICAL  
COMMISSION

COMMISSION  
ELECTROTECHNIQUE  
INTERNATIONALE

PRICE CODE  
CODE PRIX

**M**

ICS 25.160.30

ISBN 978-2-88912-502-9

## CONTENTS

FOREWORD.....	3
1 Scope.....	5
2 Normative references .....	5
3 Terms and definitions .....	5
4 Environmental conditions.....	6
5 Type tests .....	6
5.1 Test conditions .....	6
5.2 Test sequence.....	6
6 Designation .....	6
7 Protection against electric shock .....	7
7.1 Voltage rating.....	7
7.2 Insulation resistance.....	7
7.3 Dielectric strength .....	8
7.3.1 General requirement.....	8
7.3.2 Additional requirements for striking and stabilizing voltage rating .....	8
7.4 Protection of live parts against unintentional contact .....	8
8 Thermal rating .....	9
8.1 Temperature rise.....	9
8.2 Resistance to hot objects .....	9
9 Mechanical requirements.....	10
9.1 Retaining means .....	10
9.2 Welding cable entry.....	10
9.3 Penetration of the welding cable insulation.....	10
9.4 Welding cable connection.....	10
9.5 Crush strength.....	10
9.6 Dimensions .....	11
10 Marking .....	11
11 Instructions for use .....	11
Annex A (normative) Dimensions .....	12
Figure 1 – Device for testing the resistance to hot objects .....	9
Figure A.1 – Male element .....	12
Figure A.2 – Female element.....	12
Table 1 – Relation between coupling device test current and welding cables' cross-sectional area .....	7
Table 2 – Voltage rating of coupling devices .....	7
Table 3 – Crush force .....	11
Table A.1 – Dimensions for Figures A.1 and A.2 .....	13

## INTERNATIONAL ELECTROTECHNICAL COMMISSION

## ARC WELDING EQUIPMENT –

## Part 12: Coupling devices for welding cables

## FOREWORD

- 1) The International Electrotechnical Commission (IEC) is a worldwide organization for standardization comprising all national electrotechnical committees (IEC National Committees). The object of IEC is to promote international co-operation on all questions concerning standardization in the electrical and electronic fields. To this end and in addition to other activities, IEC publishes International Standards, Technical Specifications, Technical Reports, Publicly Available Specifications (PAS) and Guides (hereafter referred to as "IEC Publication(s)"). Their preparation is entrusted to technical committees; any IEC National Committee interested in the subject dealt with may participate in this preparatory work. International, governmental and non-governmental organizations liaising with the IEC also participate in this preparation. IEC collaborates closely with the International Organization for Standardization (ISO) in accordance with conditions determined by agreement between the two organizations.
- 2) The formal decisions or agreements of IEC on technical matters express, as nearly as possible, an international consensus of opinion on the relevant subjects since each technical committee has representation from all interested IEC National Committees.
- 3) IEC Publications have the form of recommendations for international use and are accepted by IEC National Committees in that sense. While all reasonable efforts are made to ensure that the technical content of IEC Publications is accurate, IEC cannot be held responsible for the way in which they are used or for any misinterpretation by any end user.
- 4) In order to promote international uniformity, IEC National Committees undertake to apply IEC Publications transparently to the maximum extent possible in their national and regional publications. Any divergence between any IEC Publication and the corresponding national or regional publication shall be clearly indicated in the latter.
- 5) IEC itself does not provide any attestation of conformity. Independent certification bodies provide conformity assessment services and, in some areas, access to IEC marks of conformity. IEC is not responsible for any services carried out by independent certification bodies.
- 6) All users should ensure that they have the latest edition of this publication.
- 7) No liability shall attach to IEC or its directors, employees, servants or agents including individual experts and members of its technical committees and IEC National Committees for any personal injury, property damage or other damage of any nature whatsoever, whether direct or indirect, or for costs (including legal fees) and expenses arising out of the publication, use of, or reliance upon, this IEC Publication or any other IEC Publications.
- 8) Attention is drawn to the Normative references cited in this publication. Use of the referenced publications is indispensable for the correct application of this publication.
- 9) Attention is drawn to the possibility that some of the elements of this IEC Publication may be the subject of patent rights. IEC shall not be held responsible for identifying any or all such patent rights.

International Standard IEC 60974-12 has been prepared by IEC technical committee 26: Electric welding.

This third edition cancels and replaces the second edition published in 2005. This edition constitutes a technical revision.

This edition includes the following significant technical changes with respect to the previous edition:

- dimensions given in Annex A become normative;
- designation is based on the range of cross-sectional area of the welding cable intended to be connected.

The text of this standard is based on the following documents:

FDIS	Report on voting
26/441/FDIS	26/446/RVD

Full information on the voting for the approval of this standard can be found in the report on voting indicated in the above table.

This publication has been drafted in accordance with the ISO/IEC Directives, Part 2.

A list of all parts of the IEC 60974 series can be found, under the general title *Arc welding equipment*, on the IEC website.

In this standard, the following print types are used:

- *conformity statements: in italic type.*

The committee has decided that the contents of this publication will remain unchanged until the stability date indicated on the IEC web site under "<http://webstore.iec.ch>" in the data related to the specific publication. At this date, the publication will be

- reconfirmed,
- withdrawn,
- replaced by a revised edition, or
- amended.

**ITeH STANDARD PREVIEW**  
**(standards.iteh.ai)**

[IEC 60974-12:2011](https://standards.iteh.ai/catalog/standards/sist/f200dfa4-3191-4d9e-a93d-a5aaf9a80c82/iec-60974-12-2011)

<https://standards.iteh.ai/catalog/standards/sist/f200dfa4-3191-4d9e-a93d-a5aaf9a80c82/iec-60974-12-2011>

## ARC WELDING EQUIPMENT –

### Part 12: Coupling devices for welding cables

#### 1 Scope

This part of IEC 60974 is applicable to coupling devices for cables used in arc welding and allied processes, designed for connection and disconnection without using tools.

This part of IEC 60974 specifies safety and performance requirements of coupling devices.

This part of IEC 60974 is not applicable to coupling devices for underwater welding.

#### 2 Normative references

The following referenced documents are indispensable for the application of this document. For dated references, only the edition cited applies. For undated references, the latest edition of the referenced document (including any amendments) applies.

IEC 60050-151, *International Electrotechnical Vocabulary (IEV) – Part 151: Electrical and magnetic devices*

IEC 60529, *Degrees of protection provided by enclosures (IP Code)*

IEC 60974-1, *Arc welding equipment – Part 1: Welding power sources*

#### 3 Terms and definitions

For the purposes of this document, the terms and definitions given in the IEC 60050-151, the IEC 60974-1, as well as the following apply.

##### 3.1

##### **coupling device**

device connecting two welding cables together or connecting a welding cable to welding equipment

##### 3.2

##### **retaining means**

mechanical arrangement that holds the coupling device in position and prevents an unintentional withdrawal, when properly connected

##### 3.3

##### **arc striking and stabilizing voltage**

voltage superimposed on the welding circuit to initiate or maintain the arc

## 4 Environmental conditions

The coupling device shall be capable of operation when the following environmental conditions prevail:

- a) range of ambient air temperature:
  - during operation: –10 °C to + 40 °C;
- b) relative humidity of the air: up to 90 % at 20 °C.

The coupling device shall withstand storage and transport at an ambient air temperature of –20 °C to + 55 °C without any damage to function and performance.

## 5 Type tests

### 5.1 Test conditions

All type tests shall be carried out on the same new and completely assembled coupling device.

All type tests shall be carried out at an ambient air temperature between 10 °C and 40 °C.

The accuracy of measuring instruments shall be:

- a) electrical measuring instruments: class 1 ( $\pm 1$  % of full-scale reading), except for the measurement of insulation resistance and dielectric strength where the accuracy of the instruments is not specified, but shall be taken into account for the measurement;
- b) temperature measuring devices:  $\pm 2$  K.

### 5.2 Test sequence

The type tests given below shall be carried out in the following sequence:

- a) general visual inspection;
- b) temperature rise, see 8.1;
- c) crush strength, see 9.5;
- d) insulation resistance, see 7.2;
- e) dielectric strength, see 7.3.

The other type tests in this part of IEC 60974 not mentioned above may be carried out in any convenient sequence.

## 6 Designation

Coupling devices shall be designated by the range of cross-sectional area of the welding cable intended to be connected. The test current at an ambient air temperature of 40 °C is given in Table 1 based on maximum cross-section area. The welding coupling device shall accept the minimum cross-sectional area as given in Table 1. Minimum cross-sectional area may be reduced to extend the coupling device fitting range.



**Table 1 – Relation between coupling device test current and welding cables' cross-sectional area**

Range of cross-sectional area mm <sup>2</sup>	Coupling device test current at 60 % duty cycle A
up to 10	125
10 to 16	150
16 to 25	200
25 to 35	250
35 to 50	300
50 to 70	400
70 to 95	500

NOTE Welding cables are rated based on cross-sectional area. Test current is defined in order that coupling device withstands the rated current of the welding cable.

Conformity shall be checked by measurement.

## 7 Protection against electric shock

### 7.1 Voltage rating

Coupling devices shall be rated in accordance with the process as given in Table 2 and the arc striking and stabilizing voltage if applicable.

IEC 60974-12:2011

<https://standards.iteh.ai/catalog/standards/sist/200df4-3191-419e-a93d-a5aa19a80c82/iec-60974-12-2011>

**Table 2 – Voltage rating of coupling devices**

Process	Voltage rating V peak	Insulation resistance MΩ	Dielectric strength V r.m.s.	Degree of protection in accordance with IEC 60529
All processes except plasma cutting	113	2,5	1 000	IP 3X
Plasma cutting	500	2,5	2 100	IP 3X

### 7.2 Insulation resistance

The insulation resistance of a new coupling device shall, after the humidity treatment, be not less than 2,5 MΩ.

Conformity shall be checked by the following test.

#### a) Humidity treatment

A humidity cabinet is maintained at a temperature  $t$  between 20 °C and 30 °C and a relative humidity between 91 % and 95 %.

The coupling device without cables fitted is brought to a temperature between  $t$  and  $t + 4$  K and is then placed for 48 h in the humidity cabinet.

#### b) Insulation resistance measurement

Immediately after the humidity treatment, the coupling device is wiped clean and tightly wrapped in a metal foil covering the external surface of the insulation.

The insulation resistance is measured by application of a d.c. voltage of 500 V between the live parts and the metal foil, the reading being made after stabilization of the measurement.

### 7.3 Dielectric strength

#### 7.3.1 General requirement

The insulation shall withstand an a.c. test voltage of 1 000 V r.m.s. without flashover or breakdown. Any discharges unaccompanied by a voltage drop are disregarded.

*Conformity shall be checked by the following test.*

The coupling device is wiped clean and tightly wrapped in a metal foil covering the external surface of the insulation.

The a.c. test voltage shall be of an approximate sine waveform with a peak value not exceeding 1,45 times the r.m.s. value, having a frequency of 50 Hz or 60 Hz, applied for 1 min between the live parts and the metal foil.

#### 7.3.2 Additional requirements for striking and stabilizing voltage rating

For couplers for use with arc striking and stabilizing voltage, the insulation shall withstand the rated peak arc striking and stabilizing voltage as rated by the manufacturer. The insulation shall withstand a high frequency voltage of pulse width 0,2  $\mu$ s to 8  $\mu$ s, a repetition frequency of 50 Hz to 300 Hz and shall be 20 % higher than the rated peak arc striking and stabilizing voltage as determined by the manufacturer.

*Conformity shall be checked by the following test.*

<https://standards.iteh.ai/catalog/standards/sist/f200dfa4-3191-4d9e-a93d->

For couplers intended for use with arc striking and stabilizing voltage, the couplers shall be subjected to the high-frequency test voltage. The full value of the high-frequency voltage is applied for 2 s between the electrode circuit and

- a) conductive surfaces;
- b) other isolated circuits.

Flashover or breakdown shall not occur. Any discharges unaccompanied by a voltage drop (corona) are disregarded.

Alternatively, for couplers intended for use with arc striking and stabilizing voltage, an a.c. test voltage of approximately sine waveform at 50 Hz or 60 Hz may be used.

### 7.4 Protection of live parts against unintentional contact

Parts designed to carry welding current and likely to be live after disconnection shall be recessed to a depth of at least 10 % of the internal diameter of the insulation with a minimum depth of 2 mm with respect to the insulating body.

As a consequence, insulation has to be able to withstand normal service conditions so that the protecting length is maintained during the life of the coupling device.

*Conformity shall be checked by linear measurement and visual inspection.*

## 8 Thermal rating

### 8.1 Temperature rise

The temperature rise caused by the current passing through a coupling device normally coupled and fitted with an untinned copper welding cable of maximum cross-sectional area as indicated in Table 1 shall not exceed 45 K at the hottest spot of the external surface.

*Conformity shall be checked by the following test.*

The coupling device is normally coupled and fitted with at least 2 m long welding cables. The coupling device is suspended by its welding cables from two wooden laths 1 m apart, hanging between the two laths in the horizontal plane about 200 mm above the ground in a draught-free area.

A continuous d.c. current equal to 75 % of the test current (equivalent to approximately 60 % duty cycle) is passed through the coupling device until the rate of the temperature rise does not exceed 2 K/h. During the total test time, the d.c. current shall be kept constant with a tolerance of  $\pm 2$  %.

### 8.2 Resistance to hot objects

The insulation shall be capable of withstanding hot objects and the effects of a normal amount of weld spatter without being ignited or becoming unsafe.

*Conformity shall be checked with a device in accordance with Figure 1.*

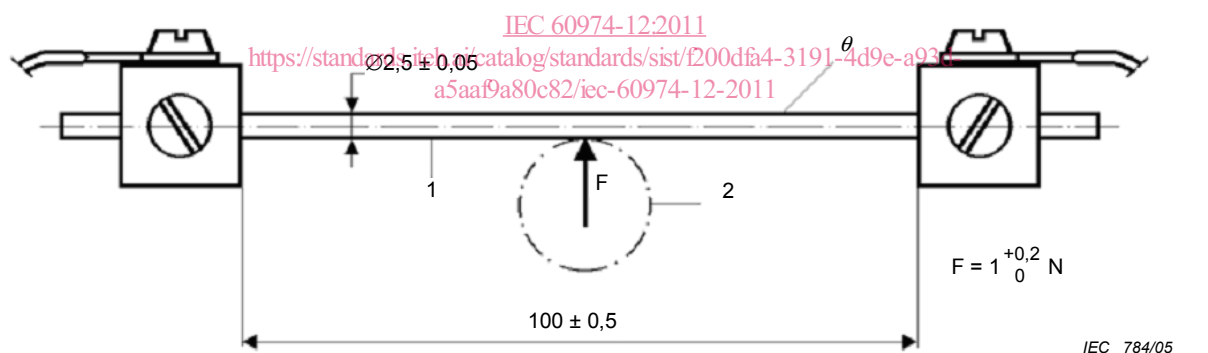

#### Key

- 1 18/8 chrome-nickel steel
  - 2 coupling device
- $\theta$  test temperature

Dimensions in millimetres

**Figure 1 – Device for testing the resistance to hot objects**

An electric current (of approximately 25 A) is passed through the rod until a steady-state temperature  $\theta$  of  $300^{+5}_0$  °C is reached. During the test, the temperature of the heated rod shall be maintained. This temperature will be measured by a contact thermometer or thermocouple.

The heated rod in a horizontal position is then applied for 2 min to the insulation at the weakest point (for example, minimum insulation thickness and closest distance to live parts). The heated rod shall not penetrate through the insulation and contact live parts.

An attempt is made to ignite any gases which may be emitted in the region of the contact point by means of an electric spark or small flame. If the gases are flammable, the burning shall stop as soon as the heated rod is removed.

## 9 Mechanical requirements

### 9.1 Retaining means

A retaining means shall be provided to prevent the unintentional separation of the coupling device as a result of a longitudinal pull.

NOTE If possible, indicating marks, for example two lines opposite each other, should show by visual inspection that the retaining means has functioned.

*Conformity shall be checked by manual operation and visual inspection.*

### 9.2 Welding cable entry

The cable entries of cable couplers shall be designed so as to prevent damage to the cable due to flexing.

*Conformity shall be checked by visual inspection.*

### 9.3 Penetration of the welding cable insulation

The design of cable couplers shall be such that the insulation of the cables can enter to a depth of at least twice the outer diameter of the welding cable with a minimum of 30 mm.

*Conformity shall be checked by measurement with a welding cable of the maximum cross-sectional area as specified by the manufacturer.*

### 9.4 Welding cable connection

The design of the coupling device shall be such that welding cables with a cross-sectional area within the range as specified by the manufacturer can be replaced. The connection shall withstand the mechanical stress of the tensile test without separation.

*Conformity shall be checked by visual inspection and by the following test.*

A plug, a connector or a plug connector is fitted in accordance with the manufacturer's instructions, with a welding cable of maximum cross-sectional area. The connection is subjected to 10 pulls with a force of 40 N/mm<sup>2</sup> of the cross-sectional area with a maximum of 2 000 N applied to the welding cable. The force of each pull is gradually increased from zero to the specified value in 1 s and maintained for 1 s.

After the test, the conductor shall not have been noticeably displaced.

This test shall be repeated with a welding cable having the minimum permissible cross-sectional area as specified by the manufacturer.

If more than one method of cable fixing is provided, all methods shall be tested.

### 9.5 Crush strength

Coupling devices shall withstand the mechanical stress of the crush test without the insulation being destroyed or the mechanical functioning being impaired.

*Conformity shall be checked by the following test, manual operation and visual inspection.*