

INTERNATIONAL STANDARD

NORME INTERNATIONALE

**Industrial communication networks – High availability automation networks –
Part 2: Media Redundancy Protocol (MRP)**

**Réseaux industriels de communication – Réseaux de haute disponibilité pour
l'automatisation –
Partie 2: Protocole de redondance du support (MRP)**

IEC 62439-2:2010

<https://standards.iteh.ai/catalog/standards/iec/597a367b-fbdc-4228-9452-51f554ea87df/iec-62439-2-2010>



THIS PUBLICATION IS COPYRIGHT PROTECTED
Copyright © 2010 IEC, Geneva, Switzerland

All rights reserved. Unless otherwise specified, no part of this publication may be reproduced or utilized in any form or by any means, electronic or mechanical, including photocopying and microfilm, without permission in writing from either IEC or IEC's member National Committee in the country of the requester.
If you have any questions about IEC copyright or have an enquiry about obtaining additional rights to this publication, please contact the address below or your local IEC member National Committee for further information.

Droits de reproduction réservés. Sauf indication contraire, aucune partie de cette publication ne peut être reproduite ni utilisée sous quelque forme que ce soit et par aucun procédé, électronique ou mécanique, y compris la photocopie et les microfilms, sans l'accord écrit de la CEI ou du Comité national de la CEI du pays du demandeur.

Si vous avez des questions sur le copyright de la CEI ou si vous désirez obtenir des droits supplémentaires sur cette publication, utilisez les coordonnées ci-après ou contactez le Comité national de la CEI de votre pays de résidence.

IEC Central Office
3, rue de Varembe
CH-1211 Geneva 20
Switzerland

Tel.: +41 22 919 02 11
Fax: +41 22 919 03 00
info@iec.ch
www.iec.ch

About the IEC

The International Electrotechnical Commission (IEC) is the leading global organization that prepares and publishes International Standards for all electrical, electronic and related technologies.

About IEC publications

The technical content of IEC publications is kept under constant review by the IEC. Please make sure that you have the latest edition, a corrigenda or an amendment might have been published.

Useful links:

IEC publications search - www.iec.ch/searchpub

The advanced search enables you to find IEC publications by a variety of criteria (reference number, text, technical committee,...).

It also gives information on projects, replaced and withdrawn publications.

IEC Just Published - webstore.iec.ch/justpublished

Stay up to date on all new IEC publications. Just Published details all new publications released. Available on-line and also once a month by email.

Electropedia - www.electropedia.org

The world's leading online dictionary of electronic and electrical terms containing more than 30 000 terms and definitions in English and French, with equivalent terms in additional languages. Also known as the International Electrotechnical Vocabulary (IEV) on-line.

Customer Service Centre - webstore.iec.ch/csc

If you wish to give us your feedback on this publication or need further assistance, please contact the Customer Service Centre: csc@iec.ch.

A propos de la CEI

La Commission Electrotechnique Internationale (CEI) est la première organisation mondiale qui élabore et publie des Normes internationales pour tout ce qui a trait à l'électricité, à l'électronique et aux technologies apparentées.

A propos des publications CEI

Le contenu technique des publications de la CEI est constamment revu. Veuillez vous assurer que vous possédez l'édition la plus récente, un corrigendum ou amendement peut avoir été publié.

Liens utiles:

Recherche de publications CEI - www.iec.ch/searchpub

La recherche avancée vous permet de trouver des publications CEI en utilisant différents critères (numéro de référence, texte, comité d'études,...).

Elle donne aussi des informations sur les projets et les publications remplacées ou retirées.

Just Published CEI - webstore.iec.ch/justpublished

Restez informé sur les nouvelles publications de la CEI. Just Published détaille les nouvelles publications parues. Disponible en ligne et aussi une fois par mois par email.

Electropedia - www.electropedia.org

Le premier dictionnaire en ligne au monde de termes électroniques et électriques. Il contient plus de 30 000 termes et définitions en anglais et en français, ainsi que les termes équivalents dans les langues additionnelles. Egalement appelé Vocabulaire Electrotechnique International (VEI) en ligne.

Service Clients - webstore.iec.ch/csc

Si vous désirez nous donner des commentaires sur cette publication ou si vous avez des questions contactez-nous: csc@iec.ch.

INTERNATIONAL STANDARD

NORME INTERNATIONALE

**Industrial communication networks – High availability automation networks –
Part 2: Media Redundancy Protocol (MRP)**

**Réseaux industriels de communication – Réseaux de haute disponibilité pour
l'automatisation –
Partie 2: Protocole de redondance du support (MRP)**

INTERNATIONAL
ELECTROTECHNICAL
COMMISSION

COMMISSION
ELECTROTECHNIQUE
INTERNATIONALE

PRICE CODE **XB**
CODE PRIX

ICS 25.040, 35.040

ISBN 978-2-88912-000-0

**Warning! Make sure that you obtained this publication from an authorized distributor.
Attention! Veuillez vous assurer que vous avez obtenu cette publication via un distributeur agréé.**

CONTENTS

FOREWORD.....	5
INTRODUCTION.....	7
1 Scope.....	8
2 Normative references.....	8
3 Terms, definitions, abbreviations, acronyms, and conventions.....	8
3.1 Terms and definitions.....	8
3.2 Abbreviations and acronyms.....	8
3.3 Conventions.....	9
4 MRP Overview.....	9
5 MRP Media redundancy behavior.....	10
5.1 Ring ports.....	10
5.2 Media Redundancy Manager (MRM).....	11
5.3 Media Redundancy Client (MRC).....	12
5.4 Redundancy domain.....	12
5.5 Usage with diagnosis and alarms.....	12
5.6 Ring diagnosis.....	13
5.7 Multiple MRM in a single ring.....	13
5.8 BLOCKED not supported (option).....	13
6 MRP Class specification.....	14
6.1 General.....	14
6.2 Template.....	14
6.3 Attributes.....	14
7 MRP service specification.....	17
7.1 Start MRM.....	17
7.2 Stop MRM.....	18
7.3 State Change.....	19
7.4 Start MRC.....	20
7.5 Stop MRC.....	21
7.6 Read MRM.....	22
7.7 Read MRC.....	24
8 MRP protocol specification.....	25
8.1 PDU description.....	25
8.1.1 Basic data types.....	25
8.1.2 DLPDU abstract syntax reference.....	25
8.1.3 Coding of the DLPDU field SourceAddress.....	26
8.1.4 Coding of the DLPDU field DestinationAddress.....	26
8.1.5 Coding of the field TagControlInformation.....	27
8.1.6 Coding of the field LT.....	27
8.1.7 MRP APDU abstract syntax.....	27
8.1.8 Coding of the field MRP_TLVHeader.....	28
8.1.9 Coding of the field MRP_Version.....	29
8.1.10 Coding of the field MRP_SequenceID.....	29
8.1.11 Coding of the field MRP_SA.....	29
8.1.12 Coding of the field MRP_Prio.....	29
8.1.13 Coding of the field MRP_PortRole.....	29
8.1.14 Coding of the field MRP_RingState.....	29

8.1.15	Coding of the field MRP_Interval	30
8.1.16	Coding of the field MRP_Transition	30
8.1.17	Coding of the field MRP_TimeStamp	30
8.1.18	Coding of the field MRP_Blocked	30
8.1.19	Coding of the field MRP_ManufacturerOUI	31
8.1.20	Coding of the field MRP_ManufacturerData	31
8.1.21	Coding of the field MRP_DomainUUID	31
8.2	Protocol machines	31
8.2.1	MRM protocol machine	31
8.2.2	MRC protocol machine	41
8.2.3	MRM and MRC functions	48
8.2.4	FDB clear timer	51
8.2.5	Topology change timer	51
9	MRP installation, configuration and repair	51
9.1	Ring port parameters	51
9.2	Ring topology parameters	52
9.3	MRM parameters	52
9.4	MRC parameters and constraints	52
9.5	Calculation of MRP ring recovery time	53
9.5.1	Overview	53
9.5.2	Deduction of formula	53
9.5.3	Worst case calculation for recovery time of 10 ms	55
9.5.4	Worst case calculation for 50 devices	56
10	MRP Management Information Base (MIB)	56
10.1	General	56
10.2	MRP MIB with a monitoring view	56
10.3	MRP MIB with a management and monitoring view	64
Bibliography	73
Figure 1	– MRP stack	10
Figure 2	– MRP ring topology with one manager and clients	11
Figure 3	– MRP open ring with MRM	11
Figure 4	– MRP ring with more than one MRM	13
Figure 5	– MRP protocol machine for MRM	32
Figure 6	– MRP protocol machine for MRC	42
Table 1	– MRP Start MRM	17
Table 2	– MRP Stop MRM	18
Table 3	– MRP Change State	19
Table 4	– MRP Start MRC	20
Table 5	– MRP Stop MRC	21
Table 6	– MRP Read MRM	22
Table 7	– MRP Read MRC	24
Table 8	– MRP DLPDU syntax for ISO/IEC 8802-3 (IEEE 802.3)	26
Table 9	– MRP OUI	26
Table 10	– MRP MulticastMACAddress	27

Table 11 – MRP TagControllInformation.Priority field.....	27
Table 12 – MRP LT field	27
Table 13 – MRP APDU syntax	28
Table 14 – MRP Substitutions.....	28
Table 15 – MRP_TLVHeader.Type.....	28
Table 16 – MRP_Version	29
Table 17 – MRP_Prio.....	29
Table 18 – MRP_PortRole	29
Table 19 – MRP_RingState.....	30
Table 20 – MRP_Interval	30
Table 21 – MRP_Transition.....	30
Table 22 – MRP_TimeStamp	30
Table 23 – MRP_Blocked.....	31
Table 24 – MRP_DomainUUID.....	31
Table 25 – MRP Local variables of MRM protocol machine.....	33
Table 26 – MRM State machine	34
Table 27 – MRP Local variables of MRC protocol machine.....	43
Table 28 – MRC state machine	43
Table 29 – MRP functions.....	49
Table 30 – MRP FDB clear timer.....	51
Table 31 – MRP topology change timer.....	51
Table 32 – MRP Network/Connection parameters	52
Table 33 – MRP MRM parameters	52
Table 34 – MRP MRC parameters.....	53

INTERNATIONAL ELECTROTECHNICAL COMMISSION

**INDUSTRIAL COMMUNICATION NETWORKS –
HIGH AVAILABILITY AUTOMATION NETWORKS –****Part 2: Media Redundancy Protocol (MRP)**

FOREWORD

- 1) The International Electrotechnical Commission (IEC) is a worldwide organization for standardization comprising all national electrotechnical committees (IEC National Committees). The object of IEC is to promote international co-operation on all questions concerning standardization in the electrical and electronic fields. To this end and in addition to other activities, IEC publishes International Standards, Technical Specifications, Technical Reports, Publicly Available Specifications (PAS) and Guides (hereafter referred to as "IEC Publication(s)"). Their preparation is entrusted to technical committees; any IEC National Committee interested in the subject dealt with may participate in this preparatory work. International, governmental and non-governmental organizations liaising with the IEC also participate in this preparation. IEC collaborates closely with the International Organization for Standardization (ISO) in accordance with conditions determined by agreement between the two organizations.
- 2) The formal decisions or agreements of IEC on technical matters express, as nearly as possible, an international consensus of opinion on the relevant subjects since each technical committee has representation from all interested IEC National Committees.
- 3) IEC Publications have the form of recommendations for international use and are accepted by IEC National Committees in that sense. While all reasonable efforts are made to ensure that the technical content of IEC Publications is accurate, IEC cannot be held responsible for the way in which they are used or for any misinterpretation by any end user.
- 4) In order to promote international uniformity, IEC National Committees undertake to apply IEC Publications transparently to the maximum extent possible in their national and regional publications. Any divergence between any IEC Publication and the corresponding national or regional publication shall be clearly indicated in the latter.
- 5) IEC itself does not provide any attestation of conformity. Independent certification bodies provide conformity assessment services and, in some areas, access to IEC marks of conformity. IEC is not responsible for any services carried out by independent certification bodies.
- 6) All users should ensure that they have the latest edition of this publication.
- 7) No liability shall attach to IEC or its directors, employees, servants or agents including individual experts and members of its technical committees and IEC National Committees for any personal injury, property damage or other damage of any nature whatsoever, whether direct or indirect, or for costs (including legal fees) and expenses arising out of the publication, use of, or reliance upon, this IEC Publication or any other IEC Publications.
- 8) Attention is drawn to the Normative references cited in this publication. Use of the referenced publications is indispensable for the correct application of this publication.

International Standard 62439-2 has been prepared by subcommittee 65C: Industrial Networks, of IEC technical committee 65: Industrial-process measurement, control and automation.

This standard cancels and replaces IEC 62439 published in 2008. This first edition constitutes a technical revision.

This edition includes the following significant technical changes with respect to IEC 62439 (2008):

- adding a calculation method for RSTP (rapid spanning tree protocol, IEEE 802.1Q),
- adding two new redundancy protocols: HSR (High-availability Seamless Redundancy) and DRP (Distributed Redundancy Protocol),
- moving former Clauses 1 to 4 (introduction, definitions, general aspects) and the Annexes (taxonomy, availability calculation) to IEC 62439-1, which serves now as a base for the other documents,
- moving Clause 5 (MRP) to IEC 62439-2 with minor editorial changes,
- moving Clause 6 (PRP) was to IEC 62439-3 with minor editorial changes,
- moving Clause 7 (CRP) was to IEC 62439-4 with minor editorial changes, and

- moving Clause 8 (BRP) was to IEC 62439-5 with minor editorial changes,
- adding a method to calculate the maximum recovery time of RSTP in a restricted configuration (ring) to IEC 62439-1 as Clause 8,
- adding specifications of the HSR (High-availability Seamless Redundancy) protocol, which shares the principles of PRP to IEC 62439-3 as Clause 5, and
- introducing the DRP protocol as IEC 62439-6.

This bilingual version (2012-12) corresponds to the English version, published in 2010-02.

The text of this standard is based on the following documents:

FDIS	Report on voting
65C/583/FDIS	65C/589/RVD

Full information on the voting for the approval of this standard can be found in the report on voting indicated in the above table.

The French version of this standard has not been voted upon.

This International Standard is to be read in conjunction with IEC 62439-1:2010, *Industrial communication networks – High availability automation networks – Part 1: General concepts and calculation methods*.

A list of the IEC 62439 series can be found, under the general title *Industrial communication networks – High availability automation networks*, on the IEC website.

This publication has been drafted in accordance with ISO/IEC Directives, Part 2.

The committee has decided that the contents of this amendment and the base publication will remain unchanged until the stability date indicated on the IEC web site under "<http://webstore.iec.ch>" in the data related to the specific publication. At this date, the publication will be

- reconfirmed,
- withdrawn,
- replaced by a revised edition, or
- amended.

INTRODUCTION

The IEC 62439 series specifies relevant principles for high availability networks that meet the requirements for industrial automation networks.

In the fault-free state of the network, the protocols of the IEC 62439 series provide ISO/IEC 8802-3 (IEEE 802.3) compatible, reliable data communication, and preserve determinism of real-time data communication. In cases of fault, removal, and insertion of a component, they provide deterministic recovery times.

These protocols retain fully the typical Ethernet communication capabilities as used in the office world, so that the software involved remains applicable.

The market is in need of several network solutions, each with different performance characteristics and functional capabilities, matching diverse application requirements. These solutions support different redundancy topologies and mechanisms which are introduced in IEC 62439-1 and specified in the other Parts of the IEC 62439 series. IEC 62439-1 also distinguishes between the different solutions, giving guidance to the user.

The IEC 62439 series follows the general structure and terms of IEC 61158 series.

The International Electrotechnical Commission (IEC) draws attention to the fact that it is claimed that compliance with this document may involve the use of a patent concerning ring protocol given in Clause 5.

IEC takes no position concerning the evidence, validity and scope of this patent right.

The holder of this patent right has assured the IEC that he/she is willing to negotiate licences either free of charge or under reasonable and non-discriminatory terms and conditions with applicants throughout the world. In this respect, the statement of the holder of this patent right is registered with IEC. Information may be obtained from:

Siemens AG A&D
Gleiwitzerstr. 555
Nürnberg 90475
Germany

and

Hirschmann Automation and Control GmbH
Stuttgarter Strasse 45-51
Neckartenzlingen 72654
Germany

Attention is drawn to the possibility that some of the elements of this document may be the subject of patent rights other than those identified above. IEC shall not be held responsible for identifying any or all such patent rights.

ISO (www.iso.org/patents) and IEC (http://www.iec.ch/tctools/patent_decl.htm) maintain on-line data bases of patents relevant to their standards. Users are encouraged to consult the data bases for the most up to date information concerning patents.

INDUSTRIAL COMMUNICATION NETWORKS – HIGH AVAILABILITY AUTOMATION NETWORKS –

Part 2: Media Redundancy Protocol (MRP)

1 Scope

The IEC 62439 series is applicable to high-availability automation networks based on the ISO/IEC 8802-3 (IEEE 802.3) (Ethernet) technology.

This part of the IEC 62439 series specifies a recovery protocol based on a ring topology, designed to react deterministically on a single failure of an inter-switch link or switch in the network, under the control of a dedicated media redundancy manager node.

2 Normative references

The following referenced documents are indispensable for the application of this document. For dated references, only the edition cited applies. For undated references, the latest edition of the referenced document (including any amendments) applies.

IEC 60050-191:1990, *International Electrotechnical Vocabulary – Chapter 191: Dependability and quality of service*

IEC 61158-6-10, *Industrial communication networks – Fieldbus specifications – Part 6-10: Application layer protocol specification – Type 10 elements*

IEC 62439-1:2010, *Industrial communication networks – High availability automation networks – Part 1: General concepts and calculation methods*

ISO/IEC 8802-3:2000, *Information technology – Telecommunications and information exchange between systems – Local and metropolitan area networks – Specific requirements – Part 3: Carrier sense multiple access with collision detection (CSMA/CD) access method and physical layer specifications*

IEEE 802.1Q, *IEEE standards for local and metropolitan area network. Virtual bridged local area networks*

IEEE 802.1D:2004, *IEEE standard for local Local and metropolitan area networks Media Access Control (MAC) Bridges*

3 Terms, definitions, abbreviations, acronyms, and conventions

3.1 Terms and definitions

For the purposes of this document, the terms and definitions given in IEC 60050-191, as well as in IEC 62439-1, apply.

3.2 Abbreviations and acronyms

For the purposes of this document, the abbreviations and acronyms given in IEC 62439-1 apply, in addition to the following.

MRC Media Redundancy Client

MRM Media Redundancy Manager

MRP Media Redundancy Protocol

3.3 Conventions

This document follows the conventions defined in IEC 62439-1.

4 MRP Overview

The Media Redundancy Protocol (MRP) specifies a recovery protocol based on a ring topology.

MRP is designed to react deterministically on a single failure of an inter-switch link or switch in the network.

MRP is based on functions of ISO/IEC 8802-3 (IEEE 802.3) and IEEE 802.1D including the Filtering Data Base (FDB) and is located between the Data Link Layer and Application Layer (see Figure 1).

NOTE 1 Layering is assumed to be according to IEC 61158-1.

A compliant network shall have a ring topology with multiple nodes.

One of the nodes has the role of a media redundancy manager (MRM). The function of the MRM is to observe and to control the ring topology in order to react on network faults. The MRM does this by sending frames on one ring port over the ring and receiving them from the ring over its other ring port, and vice-versa in the other direction.

The other nodes in the ring have the role of media redundancy clients (MRC). An MRC reacts on received reconfiguration frames from the MRM and can detect and signal link changes on its ring ports.

A compliant node shall have the ability to perform as one of the following:

- media redundancy manager (MRM),
- media redundancy client (MRC), or
- both MRM and MRC (but both roles shall not be active at the same time).

Each MRP compliant node requires a switch element with two ring ports connected to the ring.

NOTE 2 Additional ring ports may be used to connect to another ring.

Each node in the ring is able to detect the failure or recovery of an inter-switch link or the failure or recovery of a neighboring node (see 5.1).

The MRP consists of a service and a protocol entity, see stack model in Figure 1.

The service entity specifies, in an abstract way, the externally visible service provided by the Data Link Layer in terms of:

- primitive actions and events of the service,
- parameters associated with each primitive action and event, and the form which they take, and
- interrelationship between these actions and events, and their valid sequences.

MRP defines the services provided to

- the Application Layer at the boundary between the Application Layer and the Data Link Layer, and
- the MRP Management at the boundary between the Data Link Layer and the MRP Management.

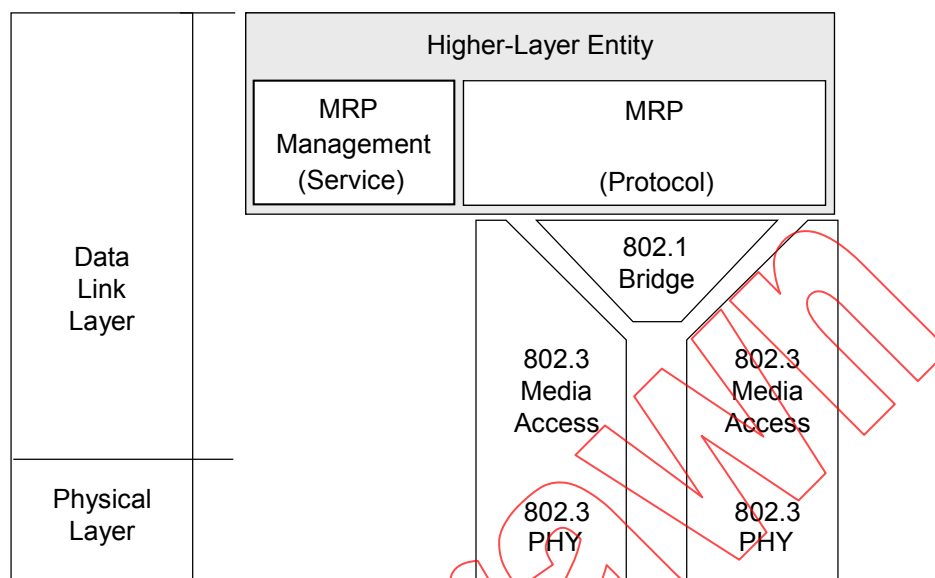

Figure 1 – MRP stack

IEC 350/10

5 MRP Media redundancy behavior

5.1 Ring ports

The MRM and the MRC shall have two ring ports.

The MRM and MRC shall be able to detect the failure or recovery of a link on a ring port with mechanisms based on ISO/IEC 8802-3 (IEEE 802.3).

The MRM and MRC shall not forward MRP_Test frames, MRP_TopologyChange frames, and MRP_LinkChange frames to non-ring ports.

A ring port shall take one of the following port states:

- **DISABLED:**
All frames shall be dropped.
- **BLOCKED:**
All frames shall be dropped except the following:
 - MRP_TopologyChange frames and MRP_Test frames.
 - MRP_LinkChange frames from an MRC.
 - Frames specified in IEEE 802.1D (2004) Table 7-10 to pass ports in “Discarding” state (e.g. LLDP, IEC 61588 (IEEE 1588) PTP).
 - Frames only produced or consumed by the higher layer entities of this node and never forwarded.
- **FORWARDING:**
All frames shall be passed through according to the forwarding behavior of IEEE 802.1D.

NOTE IEEE 802.1D refers to the port state corresponding to BLOCKED as “Discarding”.

5.2 Media Redundancy Manager (MRM)

The first ring port of the MRM shall be connected to a ring port of an MRC. The other ring port of that MRC shall be connected to a ring port of another MRC or to the second ring port of the MRM, thereby forming a ring topology as shown in Figure 2.

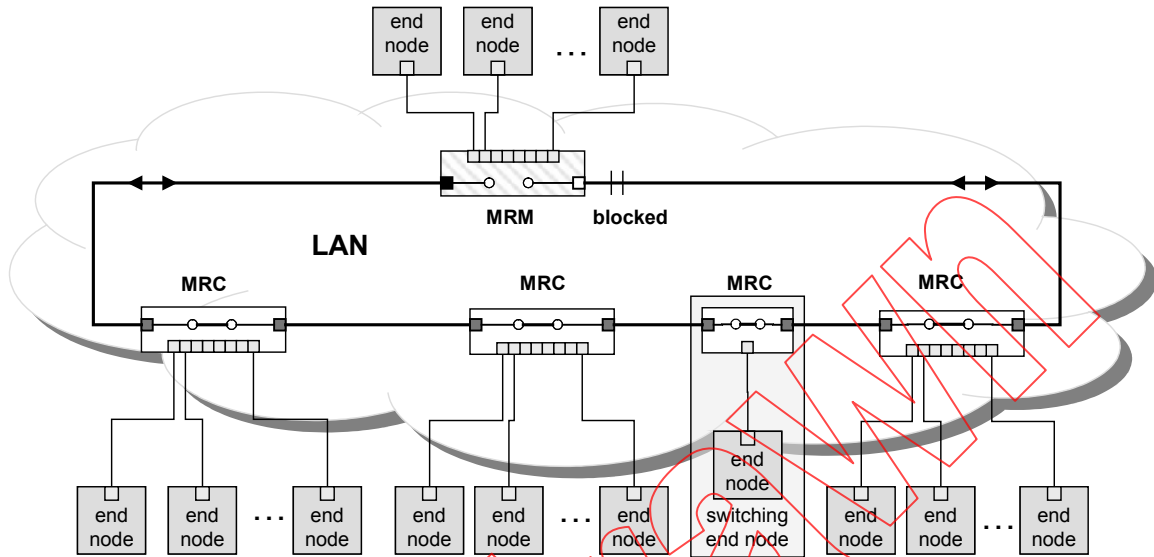

Figure 2 – MRP ring topology with one manager and clients

IEC 351/10

The MRM shall control the ring state by:

- sending MRP_Test frames at a configured time period in both directions of the ring;
- setting one ring port in FORWARDING state and the other ring port in BLOCKED state if it receives its own MRP_Test frames (this means that the ring is closed, see Figure 2);
- setting both ring ports in FORWARDING state if it does not receive its own MRP_Test frames within a configured time according to MRP_TSTdefaultT, MRP_TSTshortT and MRP_TSTNRmax in Table 33 (this means that the ring is open, see Figure 3).

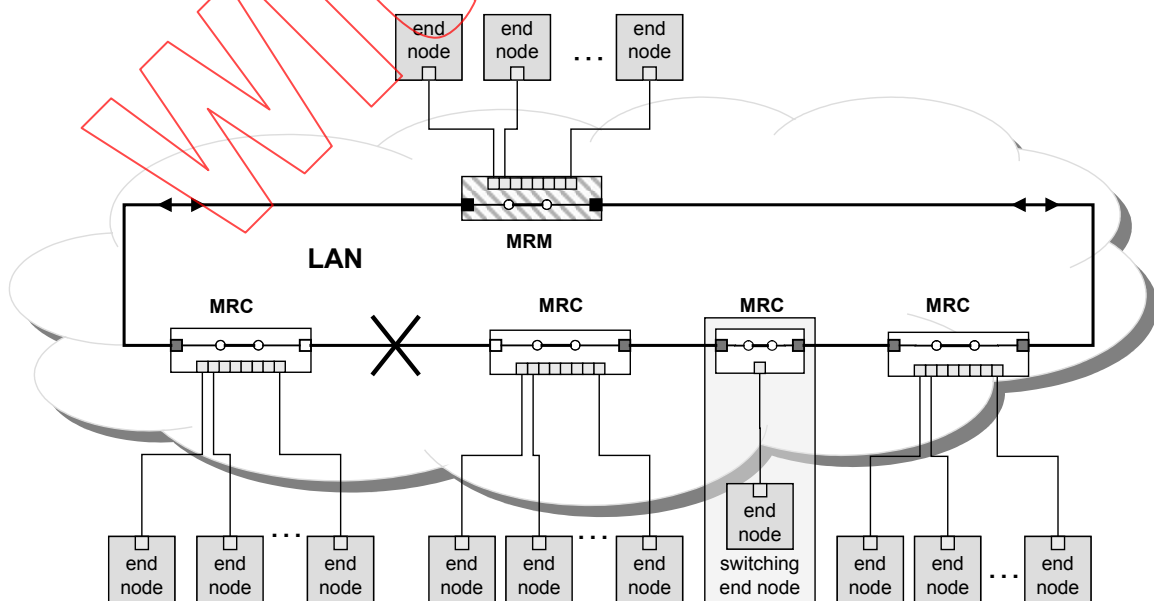

Figure 3 – MRP open ring with MRM

IEC 352/10

The following mechanism supports synchronization between MRM and MRC in ring topology changes.

The MRM shall indicate changes in the ring state to the MRCs by means of MRP_TopologyChange frames.

The MRM shall not forward MRP specific frames (MRP_Test frames, MRP_TopologyChange frames, MRP_LinkChange frames) between its ring ports.

If the MRM receives an MRP_LinkUp or MRP_LinkDown frame, then the MRM shall reduce its test monitoring time according to Table 33 to accelerate the detection of the open ring. When the open ring is detected then the MRM shall send the MRP_TopologyChange frames through both its ring ports.

Optionally the MRM shall send the MRP_TopologyChange frames through its ring ports. This option is selected by setting the parameter REACT_ON_LINK_CHANGE, see Table 26.

The MRM shall send to the MRCs an MRP_TopologyChange frame with the delay, after which the ring topology change will be performed. The parameter carrying this delay is called MRP_Interval. When this time has expired, all MRCs shall clear their filtering database (FDB).

Each MRC shall send the configured delay in MRP_Interval to the MRM in the MRP_LinkUp and MRP_LinkDown frames to tell the MRM after which time the MRC will change its port state from BLOCKED to FORWARDING (MRP_LinkUp frame) or to DISABLED (MRP_LinkDown frame).

Measures shall be included to prevent the MRM from remaining stuck in the closed state in case of node failure.

5.3 Media Redundancy Client (MRC)

Each MRC shall forward MRP_Test frames received on one ring port to the other ring port and vice versa.

If the MRC detects a failure or recovery of a ring port link, the MRC may optionally notify the change by sending MRP_LinkChange frames through both of its ring ports. Each MRC shall forward MRP_LinkChange frames received on one ring port to the other ring port and vice versa.

Each MRC shall forward MRP_TopologyChange frames received on one ring port to the other ring port and vice versa. Each MRC shall process these frames. It shall clear its FDB if requested by an MRP_TopologyChange frame in a given time interval (see Table 33, MRP_TOPchgT).

5.4 Redundancy domain

The redundancy domain represents a ring. By default, all MRM and MRCs belong to the default domain. A unique domain ID can be allocated as a key attribute, especially if an MRM or an MRC is member of multiple rings. A node shall assign exactly two unique ring ports per redundancy domain.

NOTE 1 A device may have other ports than the two assigned to MRP. These other ports are not influenced by MRP.

NOTE 2 MRP ports should behave as if RSTP is disabled.

5.5 Usage with diagnosis and alarms

If the attribute Check Media Redundancy has the value TRUE, media redundancy events shall cause diagnosis events and alarm notifications.