

INTERNATIONAL STANDARD



**Industrial communication networks – High availability automation networks –
Part 3: Parallel Redundancy Protocol (PRP) and High-availability Seamless
Redundancy (HSR)**

WITHDRAWN

<https://standards.iteh.ai/>
IEC 62439-3:2010
<https://standards.iteh.ai/en/standards/iec/8ee1ed8-b9bf-4218-86fa-decbe7b0ff30/iec-62439-3-2010>



THIS PUBLICATION IS COPYRIGHT PROTECTED

Copyright © 2010 IEC, Geneva, Switzerland

All rights reserved. Unless otherwise specified, no part of this publication may be reproduced or utilized in any form or by any means, electronic or mechanical, including photocopying and microfilm, without permission in writing from either IEC or IEC's member National Committee in the country of the requester.

If you have any questions about IEC copyright or have an enquiry about obtaining additional rights to this publication, please contact the address below or your local IEC member National Committee for further information.

IEC Central Office
3, rue de Varembe
CH-1211 Geneva 20
Switzerland
Email: inmail@iec.ch
Web: www.iec.ch

About the IEC

The International Electrotechnical Commission (IEC) is the leading global organization that prepares and publishes International Standards for all electrical, electronic and related technologies.

About IEC publications

The technical content of IEC publications is kept under constant review by the IEC. Please make sure that you have the latest edition, a corrigenda or an amendment might have been published.

- Catalogue of IEC publications: www.iec.ch/searchpub

The IEC on-line Catalogue enables you to search by a variety of criteria (reference number, text, technical committee,...). It also gives information on projects, withdrawn and replaced publications.

- IEC Just Published: www.iec.ch/online_news/justpub

Stay up to date on all new IEC publications. Just Published details twice a month all new publications released. Available on-line and also by email.

- Electropedia: www.electropedia.org

The world's leading online dictionary of electronic and electrical terms containing more than 20 000 terms and definitions in English and French, with equivalent terms in additional languages. Also known as the International Electrotechnical Vocabulary online.

- Customer Service Centre: www.iec.ch/webstore/custserv

If you wish to give us your feedback on this publication or need further assistance, please visit the Customer Service Centre FAQ or contact us:

Email: csc@iec.ch

Tel.: +41 22 919 02 11

Fax: +41 22 919 03 00

<https://standards.iec.org/standards/iec/8ec1ed8-b9bf-4218-86fa-decbe7b0ff30/iec-62439-3-2010>



IEC 62439-3

Edition 1.0 2010-02

INTERNATIONAL STANDARD



**Industrial communication networks – High availability automation networks –
Part 3: Parallel Redundancy Protocol (PRP) and High-availability Seamless
Redundancy (HSR)**

INTERNATIONAL
ELECTROTECHNICAL
COMMISSION

PRICE CODE **XA**

ICS 25.040, 35.040

ISBN 978-2-88910-706-3

CONTENTS

FOREWORD.....	5
INTRODUCTION.....	7
1 Scope.....	8
2 Normative references.....	8
3 Terms, definitions, abbreviations, acronyms, and conventions.....	8
3.1 Terms and definitions.....	8
3.2 Abbreviations and acronyms.....	9
3.3 Conventions.....	9
4 Parallel Redundancy Protocol (PRP).....	9
4.1 PRP principle of operation.....	9
4.1.1 PRP network topology.....	9
4.1.2 PRP LANs with linear or bus topology.....	10
4.1.3 PRP LANs with ring topology.....	11
4.1.4 DANP node structure.....	11
4.1.5 PRP attachment of singly attached nodes.....	12
4.1.6 Compatibility between singly and doubly attached nodes.....	12
4.1.7 Network management.....	12
4.1.8 Implication on configuration.....	13
4.1.9 Transition to non-redundant networks.....	13
4.1.10 Duplicate handling.....	14
4.1.11 Configuration check.....	18
4.1.12 Network supervision.....	18
4.1.13 Redundancy management interface.....	19
4.2 PRP protocol specifications.....	19
4.2.1 Installation, configuration and repair guidelines.....	19
4.2.2 MAC addresses.....	20
4.2.3 Multicast MAC addresses.....	20
4.2.4 IP addresses.....	20
4.2.5 Nodes.....	20
4.2.6 Duplicate accept mode.....	21
4.2.7 Duplicate discard mode.....	21
4.3 PRP service specification.....	27
4.3.1 Arguments.....	27
4.3.2 NodesTable.....	28
4.3.3 PRP write.....	29
4.3.4 PRP read.....	30
5 High-availability Seamless Redundancy (HSR).....	31
5.1 HSR objectives.....	31
5.2 HSR principle of operation.....	31
5.2.1 Basic operation with a ring topology.....	31
5.2.2 DANH node structure.....	33
5.2.3 Topology.....	34
5.2.4 RedBox structure.....	40
5.3 HSR node specifications.....	42
5.3.1 Host sequence number.....	42
5.3.2 DANH receiving from its link layer interface.....	42

5.3.3	DANH receiving from an HSR port.....	42
5.3.4	DANH forwarding rules.....	43
5.3.5	CoS.....	44
5.3.6	Clock synchronization.....	44
5.3.7	Deterministic medium access.....	44
5.4	HSR RedBox specifications.....	44
5.4.1	RedBox properties.....	44
5.4.2	RedBox receiving from interlink.....	45
5.4.3	RedBox forwarding on the ring.....	46
5.4.4	RedBox receiving from an HSR port.....	46
5.4.5	Redbox proxy node table handling.....	47
5.4.6	RedBox CoS.....	47
5.4.7	RedBox clock synchronization.....	47
5.4.8	RedBox medium access.....	47
5.5	QuadBox specification.....	47
5.6	Association definition.....	47
5.7	Frame format for HSR.....	47
5.7.1	HSR-tagged frame format.....	47
5.7.2	HSR_Supervision frame.....	48
5.7.3	Constants.....	50
6	Protocol Implementation Conformance Statement (PICS).....	51
7	PRP/HSR Management Information Base (MIB).....	51
	Bibliography.....	58
	Figure 1 – PRP example of general redundant network.....	10
	Figure 2 – PRP example of redundant network as two LANs (bus topology).....	10
	Figure 3 – PRP example of redundant ring with SANs and DANPs.....	11
	Figure 4 – PRP with two DANPs communicating.....	11
	Figure 5 – PRP RedBox, transition from single to double LAN.....	13
	Figure 6 – PRP frame extended by an RCT.....	15
	Figure 7 – PRP VLAN-tagged frame extended by an RCT.....	15
	Figure 8 – PRP constructed, padded frame closed by an RCT.....	16
	Figure 9 – PRP drop window on LAN_A.....	17
	Figure 10 – PRP drop window reduction after a discard.....	17
	Figure 11 – PRP frame from LAN_B was not discarded.....	18
	Figure 12 – PRP synchronized LANs.....	18
	Figure 13 – HSR example of ring configuration for multicast traffic.....	32
	Figure 14 – HSR example of ring configuration for unicast traffic.....	33
	Figure 15 – HSR structure of a DANH.....	34
	Figure 16 – HSR example of topology using two independent networks.....	35
	Figure 17 – HSR example of peer coupling of two rings.....	36
	Figure 18 – HSR example of connected rings.....	37
	Figure 19 – HSR example of coupling two redundant PRP LANs to a ring.....	38
	Figure 20 – HSR example of coupling from a ring node to redundant PRP LANs.....	39
	Figure 21 – HSR example of meshed topology.....	40
	Figure 22 – HSR structure of a RedBox.....	41

Figure 23 – HSR frame without VLAN tag 48

Figure 24 – HSR frame with VLAN tag 48

Table 1 – PRP_Supervision frame with VLAN tag 25

Table 2 – PRP constants 27

Table 3 – PRP arguments 28

Table 4 – PRP arguments 29

Table 5 – PRP write 29

Table 6 – PRP read 30

Table 7 – HSR_Supervision frame with optional VLAN tag 49

Table 8 – HSR Constants 50

Withdrawing

iTech Standards
(<https://standards.iteh.ai>)
Document Preview

IEC 62439-3:2010

<https://standards.iteh.ai/standards/iec/8ec1ed8-b9bf-4218-86fa-decbe7b0ff30/iec-62439-3-2010>

INTERNATIONAL ELECTROTECHNICAL COMMISSION

**INDUSTRIAL COMMUNICATION NETWORKS –
HIGH AVAILABILITY AUTOMATION NETWORKS –****Part 3: Parallel Redundancy Protocol (PRP) and
High-availability Seamless Redundancy (HSR)**

FOREWORD

- 1) The International Electrotechnical Commission (IEC) is a worldwide organization for standardization comprising all national electrotechnical committees (IEC National Committees). The object of IEC is to promote international co-operation on all questions concerning standardization in the electrical and electronic fields. To this end and in addition to other activities, IEC publishes International Standards, Technical Specifications, Technical Reports, Publicly Available Specifications (PAS) and Guides (hereafter referred to as "IEC Publication(s)"). Their preparation is entrusted to technical committees; any IEC National Committee interested in the subject dealt with may participate in this preparatory work. International, governmental and non-governmental organizations liaising with the IEC also participate in this preparation. IEC collaborates closely with the International Organization for Standardization (ISO) in accordance with conditions determined by agreement between the two organizations.
- 2) The formal decisions or agreements of IEC on technical matters express, as nearly as possible, an international consensus of opinion on the relevant subjects since each technical committee has representation from all interested IEC National Committees.
- 3) IEC Publications have the form of recommendations for international use and are accepted by IEC National Committees in that sense. While all reasonable efforts are made to ensure that the technical content of IEC Publications is accurate, IEC cannot be held responsible for the way in which they are used or for any misinterpretation by any end user.
- 4) In order to promote international uniformity, IEC National Committees undertake to apply IEC Publications transparently to the maximum extent possible in their national and regional publications. Any divergence between any IEC Publication and the corresponding national or regional publication shall be clearly indicated in the latter.
- 5) IEC itself does not provide any attestation of conformity. Independent certification bodies provide conformity assessment services and, in some areas, access to IEC marks of conformity. IEC is not responsible for any services carried out by independent certification bodies.
- 6) All users should ensure that they have the latest edition of this publication.
- 7) No liability shall attach to IEC or its directors, employees, servants or agents including individual experts and members of its technical committees and IEC National Committees for any personal injury, property damage or other damage of any nature whatsoever, whether direct or indirect, or for costs (including legal fees) and expenses arising out of the publication, use of, or reliance upon, this IEC Publication or any other IEC Publications.
- 8) Attention is drawn to the Normative references cited in this publication. Use of the referenced publications is indispensable for the correct application of this publication.

International Standard 62439-3 has been prepared by subcommittee 65C: Industrial Networks, of IEC technical committee 65: Industrial-process measurement, control and automation.

This standard cancels and replaces IEC 62439 published in 2008. This first edition constitutes a technical revision.

This edition includes the following significant technical changes with respect to IEC 62439 (2008):

- adding a calculation method for RSTP (rapid spanning tree protocol, IEEE 802.1Q),
- adding two new redundancy protocols: HSR (High-availability Seamless Redundancy) and DRP (Distributed Redundancy Protocol),
- moving former Clauses 1 to 4 (introduction, definitions, general aspects) and the Annexes (taxonomy, availability calculation) to IEC 62439-1, which serves now as a base for the other documents,
- moving Clause 5 (MRP) to IEC 62439-2 with minor editorial changes,

- moving Clause 6 (PRP) was to IEC 62439-3 with minor editorial changes,
- moving Clause 7 (CRP) was to IEC 62439-4 with minor editorial changes, and
- moving Clause 8 (BRP) was to IEC 62439-5 with minor editorial changes,
- adding a method to calculate the maximum recovery time of RSTP in a restricted configuration (ring) to IEC 62439-1 as Clause 8,
- adding specifications of the HSR (High-availability Seamless Redundancy) protocol, which shares the principles of PRP to IEC 62439-3 as Clause 5, and
- introducing the DRP protocol as IEC 62439-6.

The text of this standard is based on the following documents:

FDIS	Report on voting
65C/583/FDIS	65C/589/RVD

Full information on the voting for the approval of this standard can be found in the report on voting indicated in the above table.

This International Standard is to be read in conjunction with IEC 62439-1:2010, *Industrial communication networks – High availability automation networks – Part 1: General concepts and calculation methods*.

A list of the IEC 62439 series can be found, under the general title *Industrial communication networks – High availability automation networks*, on the IEC website.

This publication has been drafted in accordance with ISO/IEC Directives, Part 2.

The committee has decided that the contents of this amendment and the base publication will remain unchanged until the stability date indicated on the IEC web site under "http://webstore.iec.ch" in the data related to the specific publication. At this date, the publication will be

- reconfirmed,
- withdrawn,
- replaced by a revised edition, or
- amended.

A bilingual version of this standard may be issued at a later date.

IMPORTANT – The “colour inside” logo on the cover page of this publication indicates that it contains colours which are considered to be useful for the correct understanding of its contents. Users should therefore print this publication using a colour printer.

INTRODUCTION

The IEC 62439 series specifies relevant principles for high availability networks that meet the requirements for industrial automation networks.

In the fault-free state of the network, the protocols of the IEC 62439 series provide ISO/IEC 8802-3 (IEEE 802.3) compatible, reliable data communication, and preserve determinism of real-time data communication. In cases of fault, removal, and insertion of a component, they provide deterministic recovery times.

These protocols retain fully the typical Ethernet communication capabilities as used in the office world, so that the software involved remains applicable.

The market is in need of several network solutions, each with different performance characteristics and functional capabilities, matching diverse application requirements. These solutions support different redundancy topologies and mechanisms which are introduced in IEC 62439-1 and specified in the other Parts of the IEC 62439 series. IEC 62439-1 also distinguishes between the different solutions, giving guidance to the user.

The IEC 62439 series follows the general structure and terms of IEC 61158 series.

The International Electrotechnical Commission (IEC) draws attention to the fact that it is claimed that compliance with this document may involve the use of a patent concerning detection of redundant frames given in 4.1.10.3, and concerning coupling of PRP and HSR LANs given in 5.4 (patent pending).

IEC takes no position concerning the evidence, validity and scope of this patent right.

The holder of this patent right has assured the IEC that he/she is willing to negotiate licences either free of charge or under reasonable and non-discriminatory terms and conditions with applicants throughout the world. In this respect, the statement of the holder of this patent right is registered with IEC. Information may be obtained from:

ABB Switzerland Ltd
Corporate Research
Segelhofstr 1K
5405 Baden
Switzerland

Attention is drawn to the possibility that some of the elements of this document may be the subject of patent rights other than those identified above. IEC shall not be held responsible for identifying any or all such patent rights.

ISO (www.iso.org/patents) and IEC (http://www.iec.ch/tctools/patent_decl.htm) maintain on-line data bases of patents relevant to their standards. Users are encouraged to consult the data bases for the most up to date information concerning patents.

INDUSTRIAL COMMUNICATION NETWORKS – HIGH AVAILABILITY AUTOMATION NETWORKS –

Part 3: Parallel Redundancy Protocol (PRP) and High-availability Seamless Redundancy (HSR)

1 Scope

The IEC 62439 series is applicable to high-availability automation networks based on the ISO/IEC 8802-3 (IEEE 802.3) (Ethernet) technology.

This part of the IEC 62439 series specifies two redundancy protocols based on the duplication of the LAN, resp. duplication of the transmitted information, designed to provide seamless recovery in case of single failure of an inter-switch link or switch in the network.

2 Normative references

The following referenced documents are indispensable for the application of this document. For dated references, only the edition cited applies. For undated references, the latest edition of the referenced document (including any amendments) applies.

IEC 60050-191:1990, *International Electrotechnical Vocabulary – Chapter 191: Dependability and quality of service*

IEC 62439-1:2010, *Industrial communication networks – High availability automation networks – Part 1: General concepts and calculation methods*

ISO/IEC 8802-3:2000, *Information technology – Telecommunications and information exchange between systems – Local and metropolitan area networks – Specific requirements – Part 3: Carrier sense multiple access with collision detection (CSMA/CD) access method and physical layer specifications*

IEEE 802.1D:2004, *IEEE standard for local Local and metropolitan area networks Media Access Control (MAC) Bridges*

IEEE 802.1Q, *IEEE standards for local and metropolitan area network. Virtual bridged local area networks*

3 Terms, definitions, abbreviations, acronyms, and conventions

3.1 Terms and definitions

For the purposes of this document, the terms and definitions given in IEC 60050-191, as well as in IEC 62439-1, apply, in addition to the following.

3.1.1

extended frame

frame that has been extended by a Redundancy Control Trailer

3.1.2

interlink

link that connects two network hierarchies

3.1.3

RedBox

device allowing to attach single attached nodes to a redundant network

3.1.4

QuadBox

Quadruple port device connecting two peer HSR rings, which behaves as an HSR node in each ring and is able to filter the traffic and forward it from ring to ring

3.1.5

HSR frame

frame that carries the HSR EtherType

3.2 Abbreviations and acronyms

For the purposes of this document, the following abbreviations and acronyms apply, in addition to those given in IEC 62439-1:

DANH	Double attached node implementing HSR
DANP	Double attached node implementing PRP
ICMP	Internet Control Message Protocol (part of the Internet protocol suite)
RCT	Redundancy Check Tag
SRP	Serial Redundancy Protocol
VDAN	Virtual Doubly Attached Node (SAN as visible through a RedBox)

3.3 Conventions

This document follows the conventions defined in IEC 62439-1.

4 Parallel Redundancy Protocol (PRP)

4.1 PRP principle of operation

4.1.1 PRP network topology

This redundancy protocol implements redundancy in the devices, through doubly attached nodes operating according to PRP (DANPs).

A DANP is attached to two independent LANs of similar topology, named LAN_A and LAN_B, which operate in parallel. A source DANP sends the same frame over both LANs and a destination DANP receives it from both LANs within a certain time, consumes the first frame and discards the duplicate.

Figure 1 shows a redundant network consisting of two switched LANs, which can have any topology, e.g. tree, ring or meshed.

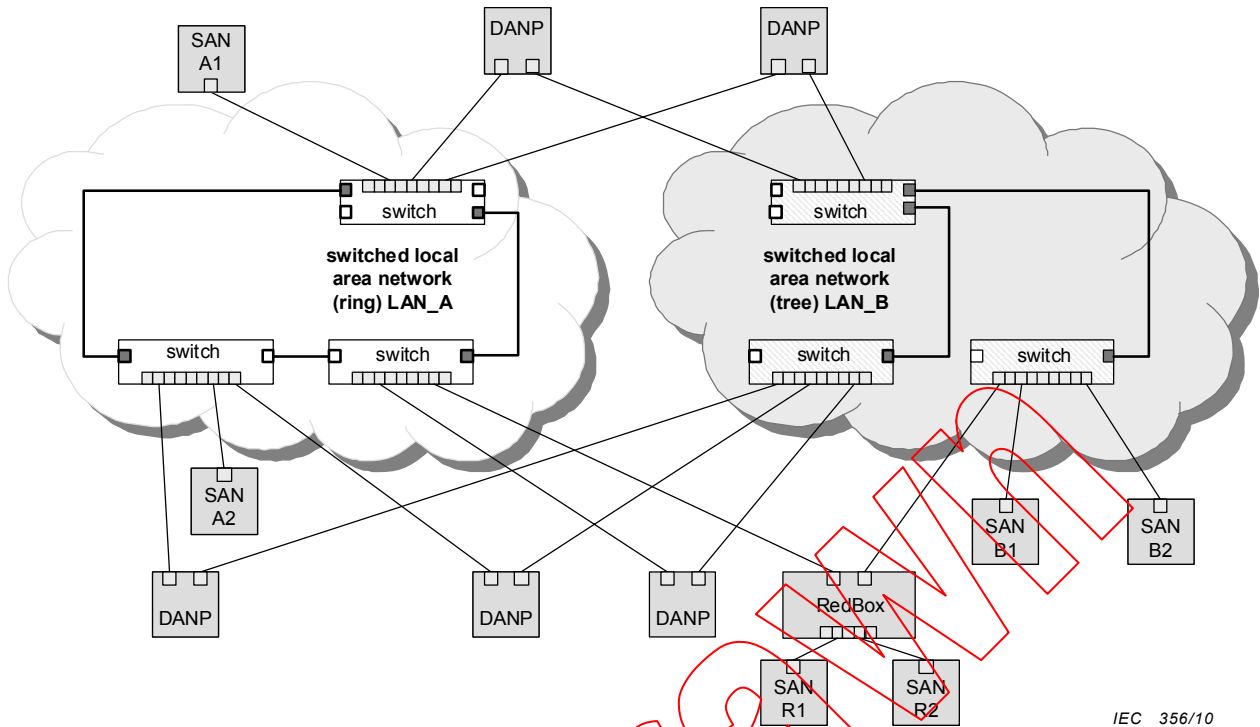

IEC 356/10

Figure 1 – PRP example of general redundant network

The two LANs are identical in protocol at the MAC-LLC level, but they can differ in performance and topology. Transmission delays may also be different, especially if one of the networks reconfigures itself, e.g. using RSTP, to overcome an internal failure.

The two LANs follow configuration rules that allow the network management protocols such as Address Resolution Protocol (ARP) to operate correctly.

The two LANs have no connection between them and are assumed to be fail-independent. Redundancy can be defeated by single points of failure, such as a common power supply or a direct connection whose failure brings both networks down. Installation guidelines in this document provide guidance to the installer to achieve fail-independence.

4.1.2 PRP LANs with linear or bus topology

As an example of a simpler configuration,

Figure 2 draws a PRP network as two LANs in linear topology, which may also be a bus topology.

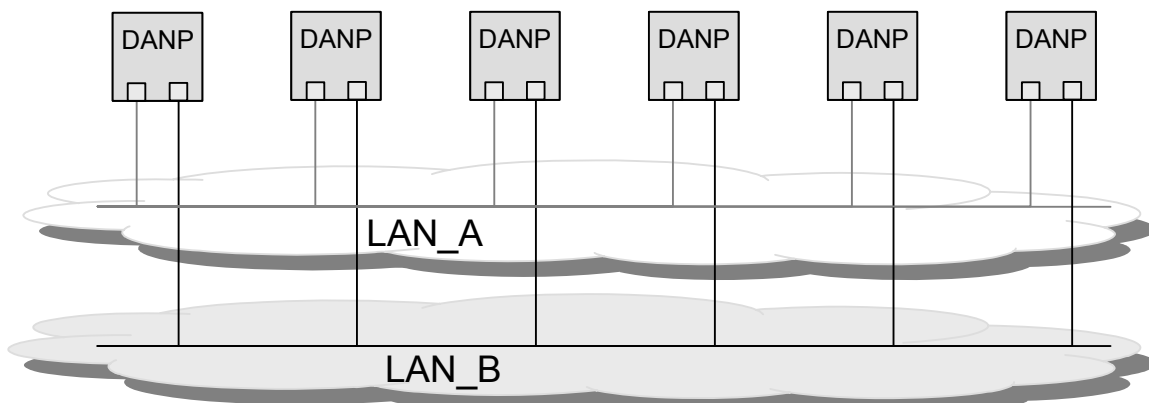

IEC 357/10

Figure 2 – PRP example of redundant network as two LANs (bus topology)

4.1.3 PRP LANs with ring topology

The two LANs can have a ring topology, as Figure 3 shows.

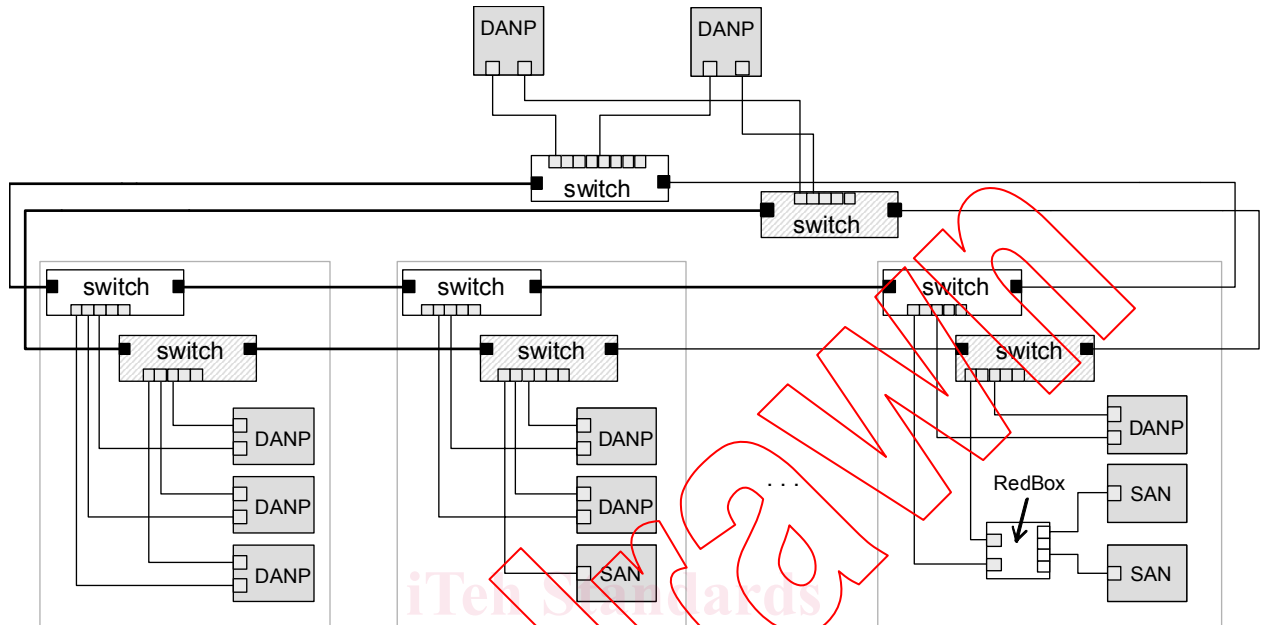

Figure 3 – PRP example of redundant ring with SANs and DANPs

IEC 358/10

4.1.4 DANP node structure

Each node has two ports that operate in parallel and that are attached to the same upper layers of the communication stack through the Link Redundancy Entity (LRE), as Figure 4 shows.

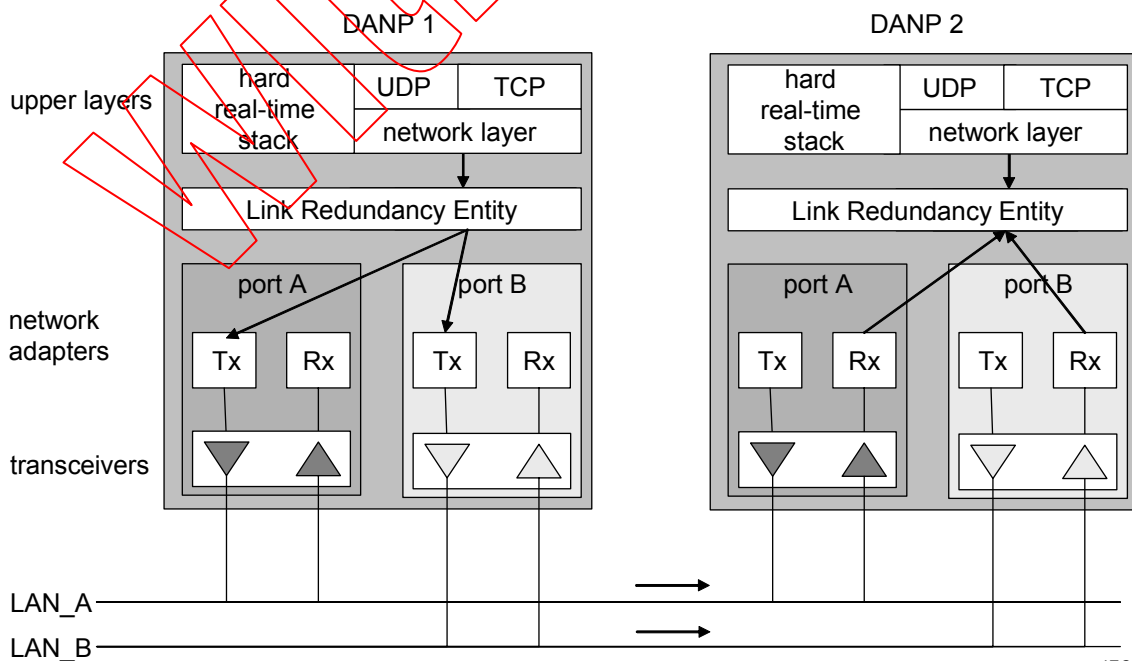

Figure 4 – PRP with two DANPs communicating

IEC 359/10

The Link Redundancy Entity (LRE) has two tasks: handling of duplicates and management of redundancy. This layer presents toward its upper layers the same interface as the network adapter of a non-redundant adapter.

When receiving a frame from the node's upper layers, the LRE sends the frame through both its ports at nearly the same time.

The two frames transit through the two LANs with different delays, ideally they arrive at the same time at the destination node.

When receiving frames from the network, the LRE forwards the first received frame of a pair to the node's upper layers and discards the duplicate frame (if it arrives).

For management of redundancy, the LRE can append a Redundancy Check Trailer (RCT) including a sequence number to the frames it sends to keep track of duplicates. In addition, the LRE periodically sends PRP_Supervision frames and evaluates the PRP_Supervision frames of the other DANPs.

4.1.5 PRP attachment of singly attached nodes

Singly attached nodes (SANs) can be attached in two ways:

- SANs can be attached directly to one LAN only. SANs can only communicate with other SANs on the same LAN. For instance, in Figure 1, SAN A1 can communicate with SAN A2, but not with SAN B1 or SAN B2. SANs can communicate with all DANPs.
- SANs can be attached over a RedBox (redundancy box) to both LANs, as Figure 1 shows for R1 and R2 (see also 4.1.9). Such SANs can communicate with all SANs, for instance SAN A1 and SAN R1 can communicate.

NOTE SANs do not need to be aware of PRP, they can be off-the-shelf computers.

In some applications, only availability-critical devices need a double attachment, for instance the operator workplaces, while the majority of the devices are SANs. Taking advantage of the basic infrastructure of PRP, a DANP can be attached to two different switches of the same LAN (e.g. a ring) and use protocols different from PRP to reconfigure the network in case of failure. The DANP then behaves as a switch element according to IEEE 802.1D. For instance, the switch element may implement the MRP protocol, the RSTP protocol, or a subset of RSTP, where there is no forwarding of traffic between the ports. These abilities are optional and not detailed in this International Standard. The supported mode is specified in the PICS (see 6).

4.1.6 Compatibility between singly and doubly attached nodes

Singly attached nodes (SAN), for instance maintenance laptops or printers that belong to one LAN, can be connected to any LAN. A SAN connected to one LAN cannot communicate directly to a SAN connected to the other LAN. Switches are always SANs. These SANs are not aware of PRP redundancy, so DANPs generate a traffic that these SANs understand. The condition is however that the SANs ignore the RCT in the frames, which should be the case since a SAN cannot distinguish the RCT from ISO/IEC 8802-3 (IEEE 802.3) padding. Conversely, DANPs understand the traffic generated by SANs, since these do not append a RCT. They only forward one frame to their upper layers since the SAN traffic uses one LAN only. If a DANP cannot positively identify that the remote device is a DANP, it considers it as a SAN.

4.1.7 Network management

A node has the same MAC address on both ports, and only one set of IP addresses assigned to that address. This makes redundancy transparent to the upper layers. Especially, this allows the Address Resolution Protocol (ARP) to work the same as with a SAN. Switches in a LAN are not doubly attached devices, and therefore all managed switches have different IP addresses. A network management tool is preferably a DANP and can access nodes and