



Designation: D 1051 – 95 (Reapproved 2000)

Standard Specification for Rubber Insulating Sleeves¹

This standard is issued under the fixed designation D 1051; the number immediately following the designation indicates the year of original adoption or, in the case of revision, the year of last revision. A number in parentheses indicates the year of last reapproval. A superscript epsilon (ϵ) indicates an editorial change since the last revision or reapproval.

1. Scope

1.1 This specification covers acceptance testing of rubber insulating sleeves for protection of workers from electrical shock.

1.2 Two types of sleeves are provided and are designated as Type I, nonresistant to ozone, and Type II, resistant to ozone.

1.3 Five classes of sleeves, differing in electrical characteristics, are provided and are designated as Class 0, Class 1, Class 2, Class 3, and Class 4.

1.4 Two styles of sleeves, differing in configuration, are provided and are designated as Style A, straight taper, and Style B, curved elbow.

1.5 All type I sleeves may be provided with or without a surface halogenation treatment.

1.6 The following safety hazards caveat pertains only to the test methods portion, Sections 16-19, of this specification: *This standard does not purport to address all of the safety concerns, if any, associated with its use. It is the responsibility of the user of this standard to establish appropriate safety and health practices and determine the applicability of regulatory limitations prior to use.* Specific safety hazards statements are given in 18.2.

2. Referenced Documents

2.1 ASTM Standards:

- D 149 Test Method for Dielectric Breakdown Voltage and Dielectric Strength of Solid Electrical Insulating Materials at Commercial Power Frequencies²
- D 297 Test Methods for Rubber Products—Chemical Analysis³
- D 412 Test Methods for Vulcanized Rubber and Thermoplastic Elastomers—Tension³
- D 518 Test Method for Rubber Deterioration—Surface Cracking³
- D 570 Test Method for Water Absorption of Plastics⁴
- D 573 Test Method for Rubber—Deterioration in an Air Oven³

¹ This specification is under the jurisdiction of ASTM Committee F18 on Electrical Protective Equipment for Workers and is the direct responsibility of Subcommittee F18.15 on Worker Personal Equipment. This standard replaces ANSI Standard J6.5, which is no longer available.

Current edition approved June 15, 1995. Published August 1995. Originally published as D 1051 – 49 T. Last previous edition D 1051 – 94.

² Annual Book of ASTM Standards, Vol 10.01.

³ Annual Book of ASTM Standards, Vol 09.01.

⁴ Annual Book of ASTM Standards, Vol 08.01.

D 624 Test Method for Tear Strength of Conventional Vulcanized Rubber and Thermoplastic Elastomers³

D 1149 Test Method for Rubber Deterioration—Surface Ozone Cracking in a Chamber³

D 1415 Test Method for Rubber Property—International Hardness³

D 2240 Test Method for Rubber Property—Durometer Hardness³

F 819 Definitions of Terms Relating to Electrical Protective Equipment for Workers⁵

F 1236 Guide for Visual Inspection of Electrical Protection Rubber Products⁵

2.2 ANSI Standard:

C84.1 Voltage Ratings for Electric Power Systems and Equipment⁶

3. Terminology

3.1 Definitions of Terms Specific to This Standard:

3.1.1 *color splash*—a splash, smear or streak of contrasting color evident on the inside or outside of the sleeves that was deposited during the dripping operation and is vulcanized into the sleeve as part of the homogeneous compound.

3.1.2 *halogenation treatment*—exposure of the entire sleeve surface area to a halogen for the purpose of reducing surface friction.

3.1.3 *user*—the employer or entity purchasing the equipment to be utilized by workers for their protection; in the absence of such an employer or entity, the individual purchasing and utilizing the protective equipment.

3.1.4 *voltage, maximum use*—the a-c voltage (rms) rating of the protective equipment that designates the maximum nominal design voltage of the energized system that may be safely worked. The nominal design voltage is equal to the phase to phase voltage on multiphase circuits.

3.1.4.1 If there is no multiphase exposure in a system area and the voltage exposure is limited to phase (polarity on d-c systems) to ground potential, the phase (polarity on d-c systems) to ground potential shall be considered to be the nominal design voltage. If electrical equipment and devices are insulated, or isolated or both, such that the multiphase exposure on a grounded wye circuit is removed, then the nominal design

⁵ Annual Book of ASTM Standards, Vol 10.03.

⁶ Available from American National Standards Institute, Inc., 11 West 42nd Street, 13th Floor, New York, NY 10036.

voltage may be considered as the phase-to-ground voltage on that circuit.

3.1.5 *voltage, nominal design*—a nominal value consistent with the latest revision on ANSI C84.1, assigned to the circuit or system for the purpose of conveniently designating its voltage class.

4. Significance and Use

4.1 This specification covers the minimum electrical, chemical, and physical properties guaranteed by the manufacturer and the detailed procedures by which such properties are to be determined. The purchaser at his option may perform or have performed any of these tests in order to verify the guarantee. Claims for failure to meet the specification are subject to verification by the manufacturer.

4.2 Sleeves are used for personal protection; therefore, when authorizing their use, a margin of safety shall be allowed between the maximum voltage on which they are used and the proof-test voltage at which they are tested. The relationship between proof-test voltage and the maximum voltage at which the sleeves shall be used is shown in Table 1.

4.3 Work practices vary from user to user, dependent upon many factors. These may include but are not limited to, operating system voltages, construction design, work procedure techniques, weather conditions, etc. Therefore, except for the restrictions set forth in this specification because of design limitations, the use and maintenance of this equipment is beyond the scope of this specification.

4.4 It is common practice and the responsibility of the user of this type of protective equipment to prepare complete instructions and regulations to govern the correct and safe use of such equipment.

5. Classification

5.1 Sleeves covered under this specification shall be designated as Type I or Type II; Class 0, Class 1, Class 2, Class 3, and Class 4; and Style A or Style B.

5.1.1 *Type I*, nonresistant to ozone, made from a high-grade *cis*-1,4-polyisoprene rubber compound of natural or synthetic origin, properly vulcanized.

5.1.2 *Type II*, resistant to ozone, made of any elastomer or combination of elastomeric compounds.

5.1.3 The class designation shall be based on the electrical properties as shown in Table 1.

5.1.4 *Style A*, straight taper design.

5.1.5 *Style B*, curved elbow design.

TABLE 1 Proof Test/Use Voltage Relationship

Class of Sleeve	A-C Proof-Test Voltage rms V	D-C Proof-Test Voltage avg, V	Maximum Use Voltage ^A a-c (rms), V
0	5 000	20 000	1 000
1	10 000	40 000	7 500
2	20 000	50 000	17 000
3	30 000	60 000	26 500
4	40 000	70 000	36 000

^AExcept for Class 0 sleeves, the maximum use voltage is based on the following formula:

Maximum use voltage (maximum nominal design voltage) = 0.95 a-c proof-test voltage – 2000 V

6. Ordering Information

6.1 Orders for sleeves under this specification should include the following information:

6.1.1 Type,

6.1.2 Class,

6.1.3 Style,

6.1.4 Size,

6.1.5 Color, and

6.1.6 With or without halogenation treatment.

6.2 The listing of types, classes, styles, sizes, and colors is not intended to mean that all shall necessarily be available from manufacturers; it signifies only that, if made, they shall conform to the details of this specification.

7. Manufacture and Marking

7.1 The sleeves shall be produced by a seamless process.

7.2 Sleeves shall have a smooth finish and self-reinforced edges.

7.3 The holes provided in sleeves for the purposes of strap or harness attachments shall have non-metallic reinforced edges and shall be nominally 8 mm (⁵/₁₆ in.) in diameter.

7.4 Each sleeve shall be marked clearly and permanently with the name of the manufacturer or supplier, ASTM D1051, type, class, size, and right or left. All such marking shall be confined to the shoulder flap area and shall be nonconducting and applied in such a manner as to not impair the required properties of the sleeves.

7.4.1 A label shall be used to identify the voltage class: Class 0—red, Class 1—white, Class 2—yellow, Class 3—green, and Class 4—orange. The other required information may be placed on the label or molded directly into the sleeve.

7.4.2 To minimize problems of marking and identification, the following standard abbreviations may be used: Regular (Rg), Large (Lg), Extra Large (XLg), and Class 1 (1), Class 2 (2), etc. Right or left shall not be abbreviated.

7.4.3 At the request of the user, the sleeves may be given a halogenation treatment to reduce surface friction. This treatment shall have no detrimental effect upon the electrical, chemical or physical properties of the sleeves.

8. Chemical and Physical Requirements

8.1 The sleeve material shall conform to the physical requirements in Table 2, the accelerated aging in 19.2.5, and, for Type I sleeves, the determination of rubber polymer in accordance with 19.1.1.

9. Electrical Requirements

9.1 Each sleeve shall be given a proof test and shall

TABLE 2 Physical Requirements

Property	Type I	Type II
Tensile strength, min, Die C, MPa (psi)	17.2 (2500)	10.3 (1500)
Tensile stress at 200 %, max, MPa (psi)	2.1 (300)	2.1 (300)
Ultimate elongation, min, %	600	500
Tension set, max at 400 %, %	25	25
Tear resistance, min, kN/m (lbf/in.)	21 (120)	14 (80)
Puncture resistance, min, kN/m (lbf/in.)	18 (100)	18 (100)
Hardness, Shore A, max	47	47
Moisture absorption, max, %	1.5	1.5

withstand the 60-Hz a-c proof-test voltage (rms value) or the d-c proof-test voltage (average value) specified in Table 1. The proof test shall be performed in accordance with Section 18. The voltage shall be applied continuously for 3 min.

9.2 The sleeve material, when tested between 50-mm (2-in.) disk electrodes with edges rounded to a radius of 6 mm (0.25 in.), shall show a 60-Hz dielectric strength of not less than 14.8 MV/m (375 V rms/mil) of specimen thickness for each individual test.

9.3 The Type II sleeve material shall show no visible effects from ozone when tested in accordance with 18.7. Any visible signs of ozone deterioration of the sleeve material such as checking, cracking, breaks, pitting, etc., shall be considered as evidence of failure to meet the requirements of Type II sleeves. In case of dispute, Method A of the ozone resistance test shall be the referee test.

10. Dimensions and Permissible Variations

10.1 The thicknesses shall fall within the limits specified in Table 3 when measured in accordance with 17.1.

10.2 The dimensions for each style and size shall fall within the limits specified in Table 4 when measured in accordance with 17.2 in conjunction with Fig. 1 and Fig. 2. Variations in sleeve length and wrist dimensions are acceptable when required to meet special physical requirements.

10.2.1 The taper of sleeves should be uniform as this is significant because of the advent of dry-form electrical testing.

11. Workmanship and Finish

11.1 Sleeves shall be free on both inner and outer surface of harmful physical irregularities that can be detected by thorough test and inspection.

11.1.1 Harmful physical irregularities may be defined as any feature that disrupts the uniform, smooth surface contour and represents a potential hazard to the user, such as pinholes, cracks, blisters, cuts, conductive imbedded foreign matter, creases, pinch marks, voids (entrapped air), prominent ripples, and prominent mold marks.

11.2 Nonharmful physical irregularities may be defined as surface irregularities present on the inner and outer surfaces of the rubber sleeve due to imperfections on forms or molds and inherent difficulties in the manufacturing process. These irregularities may appear as mold marks that look like cuts even though they are actually a raised ridge of rubber, indentations, protuberances, or imbedded foreign material that are acceptable provided that:

11.2.1 The indentations, protuberance or mold marks tend to blend into a smooth slope upon stretching of the material.

11.2.2 The rubber thickness at any irregularity conforms to the thickness requirements.

11.2.3 Foreign material remains in place when the sleeve is folded and stretched with the material surrounding it.

11.2.4 Color splashes are no longer than 3 mm in any direction on a surface of the sleeve.

12. Guarantee

12.1 The manufacturer or supplier shall replace, without charge to the purchaser, unused sleeves which, at any time within a period of 9 months from date of initial delivery of shipment to the purchaser or designee, fail to pass the tests in this specification. This guarantee will be binding on the manufacturer or supplier only if the sleeves have been properly stored and have not been subjected to more than an original acceptance test and one retest.

12.2 Any acceptance test made by the purchaser’s designee, shall be performed within the first 2 months of the guarantee period unless otherwise specified.

NOTE 1—Proper storage means that sleeves are stored right side out, not distorted and not stored directly above or in proximity to steam pipes, radiators, or other sources of artificial heat, or exposed to direct sunlight or other sources of ozone. It is desirable that the ambient storage temperature shall not exceed 35°C (95°F).

13. Sampling

13.1 Each sleeve in a lot or shipment shall be subject to inspection and test to meet the requirements of Sections 7, 10, 11, 15, and 9.1.

13.2 An original sample of 1 % of the lot or shipment or not less than two sleeves, whichever is greater, shall be selected at random from the lot or shipment for the test requirements of Sections 8, 9.2 and 9.3. Where a failure occurs in the first sample, a second sample of the same quantity shall be selected and tested.

14. Rejection

14.1 Individual sleeves shall be rejected if they fail to meet requirements of Sections 7 and 11, 9.1 and the minimum requirement of 10.1.

14.2 Individual sleeves may be rejected at the option of the purchaser if they fail to meet the requirements of Sections 15 and 10.2.

14.3 The entire lot or shipment of sleeves shall be rejected under any of the following conditions:

14.3.1 If 5 % or more, but not less than two sleeves, in a lot or shipment fail to meet the requirements of 9.1.

14.3.2 If two dielectric breakdowns that do not meet the requirements of 9.2 occur in the sample.

14.3.3 If one dielectric breakdown in the original sample and one or more dielectric breakdowns in the second sample fail to meet the requirements of 9.2.

14.3.4 If the sample of Type II sleeves using the sampling methods of 13.2 fails to meet the requirements of 9.3.

14.4 The testing shall be terminated and the manufacturer or supplier notified if, during the course of testing, the sleeves in a lot or shipment fail to meet the requirements of 9.1, 9.2, or 9.3, as determined by the rejection criteria of 14.3.1, 14.3.2, 14.3.3, or 14.3.4. The manufacturer or supplier may in such a case require the purchaser to submit proof that the test procedure and equipment conform to the appropriate paragraphs of Section 18. When such proof has been furnished, the

TABLE 3 Thickness

Class of Sleeve	Minimum		Maximum	
	mm	in.	mm	in.
0	0.51	0.020	1.02	0.040
1	0.76	0.030	1.52	0.060
2	1.27	0.050	2.54	0.100
3	1.90	0.075	2.92	0.115
4	2.54	0.100	3.56	0.140

TABLE 4 Dimensions and Tolerances

Style	Size	Dimensions ^A							
		A		B		C		D	
		mm	in.	mm	in.	mm	in.	mm	in.
Straight taper (Fig. 1)	regular	667	26¼	394	15½	286	11¼	140	5½
	large	724	28½	432	17	327	12⅞	175	6⅞
	extra large	762	30	483	19	337	13¼	175	6⅞
Curved elbow (Fig. 2)	regular	673	26½	394	15½	311	12¼	146	5¼
	large	705	27¾	406	16	327	12⅞	175	6⅞
	extra large	749	29½	445	17½	327	12⅞	178	7

^ATolerances shall be as follows:
 A—±13 mm (±½ in.)
 B—Minimum allowable length
 C—±13 mm (±½ in.)
 D—±6 mm (±¼ in.)

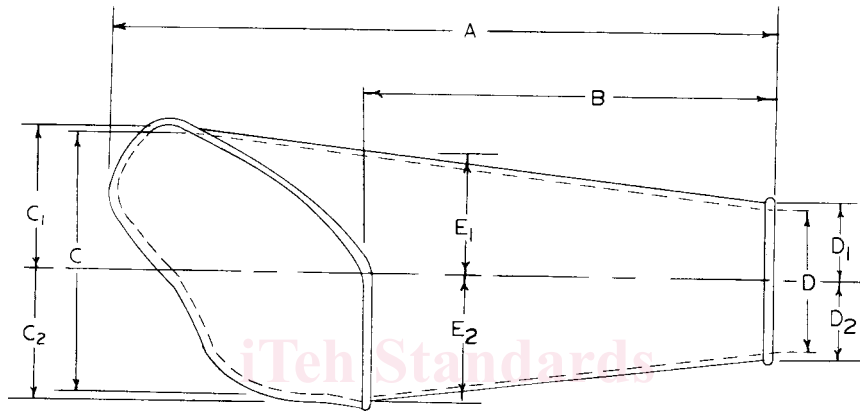

FIG. 1 Style A, Straight Taper Sleeve

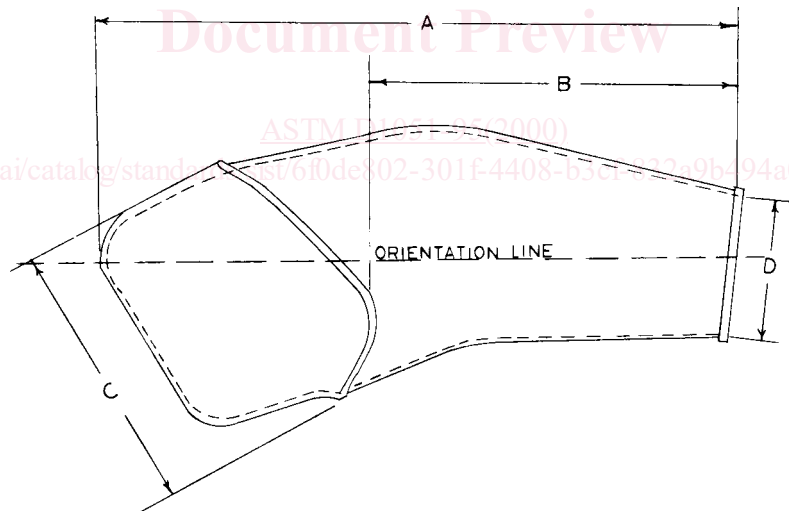

FIG. 2 Style B, Curved Elbow Sleeve

manufacturer or supplier may request that his representative witness the testing of additional sleeves from the shipment.

14.5 The entire lot or shipment may be rejected at the option of the purchaser, if two specimens of the first sample and one of the second sample, selected in accordance with 13.2, fail any of the separate requirements outlined in Section 8.

14.6 The entire lot or shipment of sleeves may be rejected at the option of the purchaser if 25 % of the sleeves in the lot or shipment fail to meet the requirements of Section 10 or 11.

14.7 All rejected material shall be returned as directed by the manufacturer, at his or the supplier's request, without being

defaced by rubber stamp or other permanent marking. However, those sleeves punctured when tested under 9.1 and 9.2 shall be stamped, punched, or cut prior to being returned to the supplier to indicate that they are unfit for electrical use.

15. Packaging

15.1 Each pair of sleeves shall be packed in an individual container of sufficient strength to properly protect the sleeves from damage in transit. The end of the container shall be marked with the name of the manufacturer or supplier, type, class, style, size, and color.