

IEC 61076-2-101
(Second edition – 2008)

Connectors for electronic equipment – Product requirements –
Part 2-101: Circular connectors – Detail specification for M12 connectors with screw-locking

CORRIGENDUM 1

1.3 Ratings and characteristics

Instead of:

Rated voltage	C-coding	5 and 6 contacts	250 V d.c. or a.c.
---------------	----------	------------------	--------------------

read:

Rated voltage	C-coding	5 contacts	60 V d.c. or a.c.
		6 contacts	30 V d.c. or a.c.

3.2.1 Pin front view A-coding

Replace existing Figure 21 – Pin front view A-coding by the following:

(<https://standards.iteh.ai>)
Document Preview

<https://standards.iteh.ai/catalog/standards/iec/c97/44b2-a25f-4268-acdd-e2df7a5dc2b9/iec-61076-2-101-2008-cor1-2010>

3.2.3 Pin front view C-coding

Replace existing **Figure 27 – Pin front view 5 way with C-coding**, by the following:

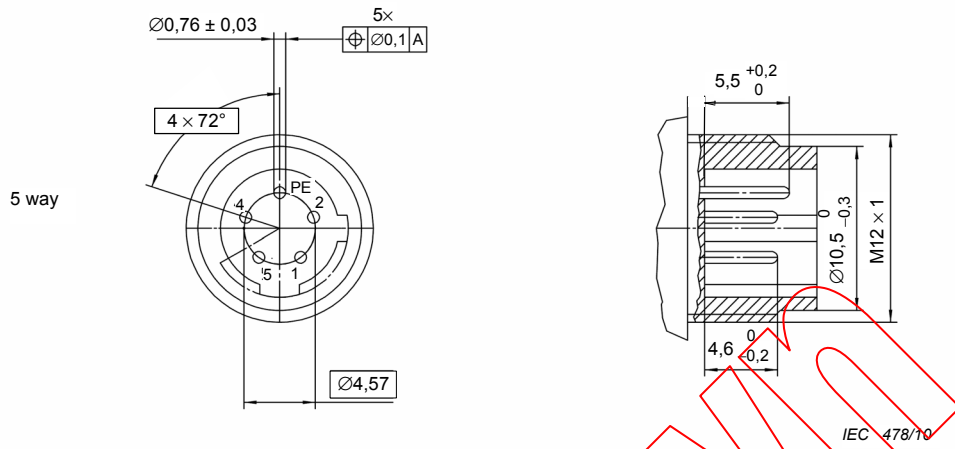

Figure 27 – Pin front view 5 way with C-coding