

INTERNATIONAL STANDARD

ISO
10322-1

First edition
1991-12-15

Ophthalmic optics — Semi-finished lens blanks —

Part 1:

Specifications for single-vision and multifocal
lens blanks

iTeh STANDARD PREVIEW
(standards.iteh.ai)

Optique ophtalmique — Verres semi-finis —

<https://standards.iteh.ai/catalog/standards/sist/42e67366-49f3-48a0-bc4c-71a5a76c186/iso-10322-1-1991>

Partie 1: Spécifications pour les verres unifocaux et multifocaux



Reference number
ISO 10322-1:1991(E)

Foreword

ISO (the International Organization for Standardization) is a worldwide federation of national standards bodies (ISO member bodies). The work of preparing International Standards is normally carried out through ISO technical committees. Each member body interested in a subject for which a technical committee has been established has the right to be represented on that committee. International organizations, governmental and non-governmental, in liaison with ISO, also take part in the work. ISO collaborates closely with the International Electrotechnical Commission (IEC) on all matters of electrotechnical standardization.

Draft International Standards adopted by the technical committees are circulated to the member bodies for voting. Publication as an International Standard requires approval by at least 75 % of the member bodies casting a vote.

International Standard ISO 10322-1 was prepared by Technical Committee ISO/TC 172, *Optics and optical instruments*, Sub-Committee SC 8, *Ophthalmic optics*.

ISO 10322 consists of the following parts, under the general title *Ophthalmic optics — Semi-finished lens blanks*:

- Part 1: *Specifications for single-vision and multifocal lens blanks*
- Part 2: *Specifications for progressive power lens blanks*

© ISO 1991

All rights reserved. No part of this publication may be reproduced or utilized in any form or by any means, electronic or mechanical, including photocopying and microfilm, without permission in writing from the publisher.

International Organization for Standardization
Case Postale 56 • CH-1211 Genève 20 • Switzerland

Printed in Switzerland

Ophthalmic optics — Semi-finished lens blanks —

Part 1:

Specifications for single-vision and multifocal lens blanks

1 Scope

This part of ISO 10322 specifies requirements for the optical and geometric properties of semi-finished single vision and multifocal lens blanks.

2 Normative references

The following standards contain provisions which, through reference in this text, constitute provisions of this part of ISO 10322. At the time of publication, the editions indicated were valid. All standards are subject to revision, and parties to agreements based on this part of ISO 10322 are encouraged to investigate the possibility of applying the most recent editions of the standards indicated below. Members of IEC and ISO maintain registers of currently valid International Standards.

ISO 8598:—¹⁾, *Optics and optical instruments — Focimeters.*

ISO 8980-1:—¹⁾, *Ophthalmic optics — Finished single-vision corrective lenses — Part 1: General requirements.*

3 Definitions

For the purposes of this part of ISO 10322, the following definitions apply.

3.1 semi-finished blanks: Semi-finished blanks are composed of two surfaces: a finished surface and an unfinished surface.

3.1.1 single-vision semi-finished blanks: Blanks which, after surfacing, are designed to provide a single corrective power.

3.1.2 multifocal semi-finished blanks: Blanks which, after surfacing, are designed to provide two or more corrective powers over different areas.

NOTE 1 This definition includes blanks with blended segments.

3.1.3 progressive power semi-finished blanks: Blanks which, after surfacing, are designed to provide a continuous change rather than discrete changes of corrective power over a part or the whole of the surface.

NOTE 2 Some lens designs may incorporate characteristics of both multifocal and progressive power blanks. In these cases, manufacturing tolerances would apply in accordance with the most appropriate classification of the characteristic.

3.2 corrective power: A general term comprising the spherical and cylindrical vertex power as well as the prismatic power of an ophthalmic lens.

3.3 vertex power: There are two vertex powers of a lens:

- back vertex power [expressed in dioptres (D)]: the reciprocal of the paraxial back vertex focal length measured in metres;
- front vertex power [expressed in dioptres (D)]: the reciprocal of the paraxial front vertex focal length measured in metres.

NOTE 3 In accordance with convention, the back vertex power is specified as the "power" of a corrective lens; the front vertex power is, however, required for certain purposes, e.g. in the measurement of addition power.

1) To be published.

3.4 surface cylinder power: The difference between the surface powers of the principal meridians on the finished surface.

3.5 nominal surface cylinder power: The cylinder power stated by the manufacturer.

3.6 prismatic power: The deviation of a ray of light through a specified point on a lens.

NOTE 4 The unit is the prism dioptre (Δ) and is expressed in centimetres deviation per metre distance (cm/m).

3.7 distance design reference point: That point on a lens blank stipulated by the manufacturer at which the design specifications for the distance portion are to apply.

NOTE 5 The distance design reference point is assumed to be the blank geometric centre unless otherwise stated.

3.8 near design reference point: That point on a lens blank stipulated by the manufacturer at which the design specifications for the near portion are to apply.

3.9 surface power, F : The ability of a surface (or part of a surface) to change the vergence of a paraxial beam of light incident normally at the surface.

NOTE 6 Surface power is calculated from the equation

$$F = (n - 1)/r$$

where

r is the radius of curvature, in metres;

n is the refractive index of the material.

F is positive for convex surfaces and negative for concave surfaces. It is expressed in dioptres (D).

3.10 nominal surface power: The surface power stated by the manufacturer for purposes of identification.

3.11 addition power: The difference between the vertex power of the near portion and the vertex power of the distance portion.

NOTE 7 See 6.2 for measurement.

4 Classification

Semi-finished lens blanks are classified as follows:

- a) single-vision semi-finished blanks;
- b) multifocal semi-finished blanks;
- c) progressive power semi-finished blanks.

5 General requirements

NOTE 8 The tolerances apply for a temperature of $23\text{ }^\circ\text{C} \pm 5\text{ }^\circ\text{C}$.

5.1 Optical tolerances of the finished surface

5.1.1 Surface power

The maximum tolerances on the nominal surface power as specified in table 1 shall apply at the distance design reference point and shall be measured using the method described in 6.3.

Table 1 — Tolerances on surface power for spherical surfaces

Values in dioptres

Distance surface power	Tolerance on surface power	Tolerance on astigmatism for spherical surfaces
	$\frac{F_1 + F_2}{2}$	$F_1 - F_2$
0,00 to 2,00	$\pm 0,09$	0,04
> 2,00 to 10,00	$\pm 0,06$	0,04
> 10,00 to 15,00	$\pm 0,09$	0,04
> 15,00 to 20,00	$\pm 0,12$	0,06
> 20,00	$\pm 0,25$	0,06

NOTE — In order to achieve the required tolerances on the finished power specified in ISO 8980-1, it may be necessary to measure the surface power of each semi-finished blank and then surface the unsurfaced side accordingly.

5.1.2 Uniformity of surface power of lenses with spherical surfaces

Over a zone of 40 mm diameter centred around the design reference point, the surface power shall not deviate by more than 0,06 D from the surface power measured at the distance design reference point. The uniformity shall be determined using the method described in 6.4.

NOTE 9 This requirement is not applicable to non-spherical lenses.

5.1.3 Surface cylinder power

The maximum tolerances on surface cylinder power as specified in table 2 shall apply at the distance design reference point and shall be measured using a method described in 6.3.

Table 2 — Tolerances on surface cylinder power for cylindrical surfaces

Values in dioptres

Nominal cylinder power	Tolerance
0,25 to 4,00	$\pm 0,06$
> 4,00 to 6,00	$\pm 0,09$
> 6,00	$\pm 0,12$

5.1.4 Addition power and prismatic power for multifocals

5.1.4.1 Addition power tolerance

When measured by the method described in 6.2, the tolerances on the addition power up to 4,00 D shall be $\pm 0,12$ D.

5.1.4.2 Tolerance on prescribed prism in the segment

The maximum deviation from the prescribed prism shall not exceed 0,25 Δ when measured at the near design reference point.

5.2 Material and surface quality

5.2.1 Finished surface

In a zone of 40 mm diameter, centred around the distance design reference point and also over the whole area of the segment if the segment is not more than 30 mm in diameter, the lens blank when inspected using the method described in 6.1 shall not exhibit any defect internally or on the finished surface which can impair the vision. For segments

over 30 mm in diameter, the inspection area shall be a 30 mm diameter zone centred around the near design reference point.

NOTE 10 Outside the stated zones, small isolated material and/or surface defects are acceptable.

5.2.2 Unfinished surface

In the case of a multifocal semi-finished blank, the surface quality of the unfinished surface should be of sufficient quality to allow, if necessary, inspection of the lens blank, to determine the addition power and prismatic power and to allow the use of projection type layout markers.

5.3 Geometric tolerances

5.3.1 Dimensions of blanks

5.3.1.1 Sizes of blanks

Sizes of blanks are classified as follows:

- nominal size (d_n): dimension(s), in millimetres, indicated by the manufacturer;
- effective size (d_e): actual dimension(s), in millimetres, of the lens blank;
- usable size (d_u): dimension(s), in millimetres, of the area that is optically usable and is free from the presence of bevels, edge defects, etc.

NOTE 11 Isolated peripheral identification marks, peripheral flaws, chips and bubbles are acceptable.

5.3.1.2 Tolerances on minimum size

- effective size:

$$d_e \geq d_n - 1 \text{ mm}$$

- usable size:

$$d_u \geq d_n - 1 \text{ mm for } d_n \leq 65 \text{ mm}$$

$$d_u \geq d_n - 2 \text{ mm for } d_n > 65 \text{ mm}$$

NOTE 12 The tolerance on usable size does not apply to blanks with a carrier curve such as lenticulars.

5.3.2 Thickness

5.3.2.1 Centre thickness

When measured at the geometric centre of the lens blank, unless otherwise stated by the manufacturer, the centre thickness of the lens blank shall be not less than the minimum thickness stated by the manufacturer.

5.3.2.2 Edge thickness

When measured at the point stated by the manufacturer, the edge thickness of the lens blank shall be not less than the minimum thickness stated by the manufacturer.

5.3.3 Segment tolerances for multifocals

5.3.3.1 Dimensions

When using the method described in 6.5, the segment dimensions (width, depth and intermediate depth) shall not deviate from the nominal value by more than 0,5 mm.

If sold as a matched pair, the segment dimensions (width, depth and intermediate depth) shall not differ by more than 0,7 mm.

5.3.3.2 Positions

The segment position shall be measured from the distance design reference point using the measurement method described in 6.5. The horizontal position (segment inset) shall be the distance, in millimetres, from the distance design reference point to the vertical bisector of the segment. The vertical position (segment drop) shall be the distance, in millimetres, from the distance design ref-

erence point to the segment line (or the highest point of the segment for segments with curved tops).

Neither the horizontal nor the vertical position shall deviate from the nominal value by more than $\pm 1,0$ mm.

NOTE 13 Segment size and position tolerances are applicable only if the segment boundaries are clearly delineated or if the segment does not reach the edge of the blank.

6 Test methods

The measurement of optical power shall be carried out in accordance with ISO 8598 or an equivalent method.

6.1 Material and surface quality

The lens inspection is carried out at a light/dark boundary and without the aid of magnifying optics. Inspect the lens within a room with lighting of about 200 lx. Use as an inspection lamp either a fluorescent tube with a minimum of 15 W or an open-shaded 40 W incandescent clear lamp. Position the lens about 300 mm from the light source and view against a dark background (see figure 1).

NOTE 14 This observation is subjective and requires some experience.

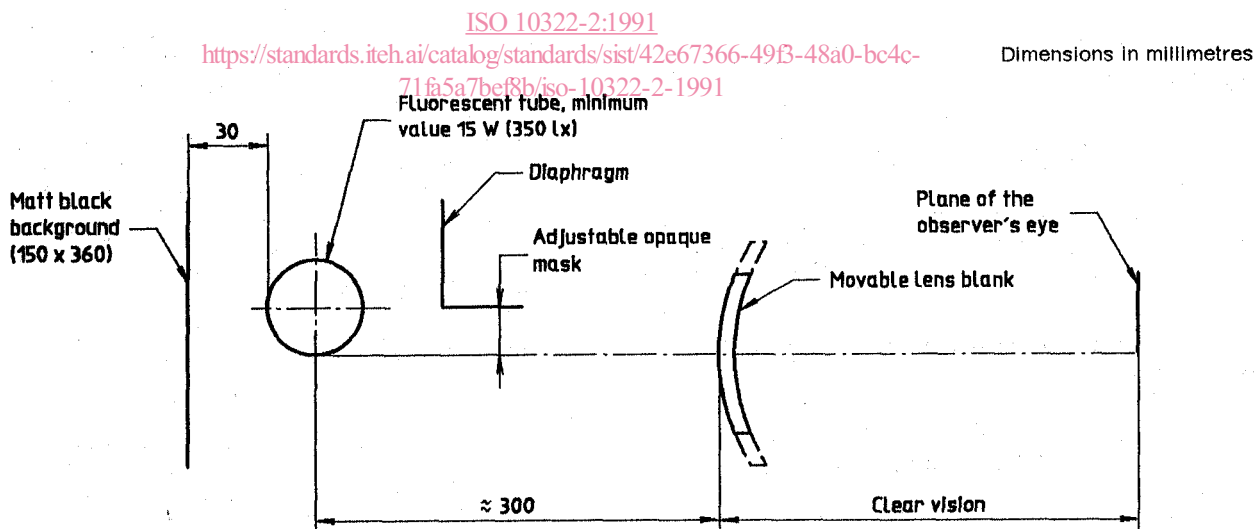

NOTE — The diaphragm is adjusted to shield the eye from the light source and to allow the lens to be illuminated by the light.

Figure 1 — Recommended system for visually inspecting a lens for defects

6.2 Addition power measurement method

Place the lens blank so that the surface containing the segment is against the focimeter lens support and locate the blank at the near design reference point.

When using a focusing focimeter, measure the near vertex power by focusing the most vertical lines of the target.

Measure the distance vertex power at the same distance above and to the side of the distance design reference point that the near vertex power measurement was carried out below and to the side of the distance design reference point (see figure 2).

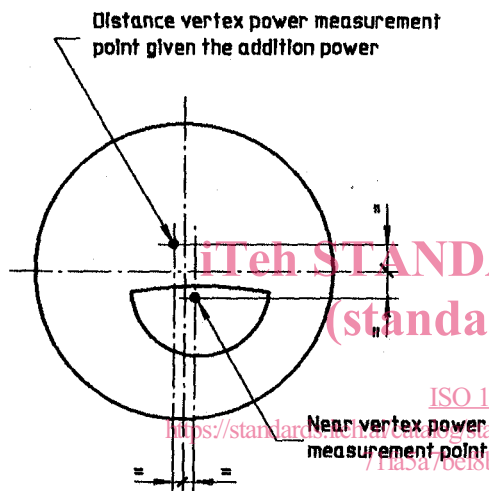

Figure 2 — Measurement of the distance vertex power

Calculate the addition as the difference between the near vertex power and the distance vertex power.

NOTES

15 Other measurement methods are acceptable if shown to perform equivalently to the above reference method.

16 In the case of an aspheric lens, the distance design reference point and the method of measurement should be specified by the manufacturer.

6.3 Measurement method for surface power at the distance design reference point

Determine the surface power at the distance design reference point using any method of sufficient accuracy. An example of one such method is a precision dial indicator capable of measuring a toric surface.

6.4 Measurement method for uniformity of surface power of spherical surfaces

The surface power uniformity is determined using any method of sufficient accuracy and measured over a 40 mm diameter circle centred on the distance design reference point. Two such methods are the Newton ring test or the use of a calibrated sagittal height gauge.

6.5 Segment size and position measurement method

Measure the segment size in the tangential plane to the centre of the segment and measure the position in plan view. For example, suitable methods utilize a shadowgraph, an optical comparator fitted with the appropriate graticule or a precision millimetric measuring instrument.

7 Identification

7.1 Identification required on the package

The lens blank shall be supplied in a package. This package shall be labelled with at least the following information (see also clause 8).

7.1.1 All lens blanks

- The nominal surface power, in dioptres.
- If required, the nominal surface cylinder, in dioptres.
- The nominal size of the lens blank, in millimetres.
- The colour (if not white).
- The material of the blank, its refractive index and the trade name of the manufacturer or supplier.

7.1.2 Multifocal lens blanks

- The addition power, in dioptres.
- The style designation or trade mark.
- If applicable, width or segment dimension(s), in millimetres.
- If applicable, right or left eye.
- If applicable, segment prism, in prism dioptres.

7.2 Information to be made available

The following information shall be available on request.

- a) The centre thickness, in millimetres (see 5.3.2.1).
- b) The edge thickness, in millimetres, and identification of the measurement point (see 5.3.2.2).
- c) The curvature or radius of the unfinished surface.
- d) The surface power or tool power (see note 17) or the radius for both surfaces (finished and unfinished).

NOTE 17 The tool power is defined as surface power using a specified refractive index.

- e) The optical properties (constringence, spectral transmittance).
- f) If different from 6.2, the method of measuring the addition power.

8 Reference to this part of ISO 10322

If the manufacturer or supplier claims compliance with this part of ISO 10322, reference shall be made to ISO 10322-1 either on the package or in the available literature.

iTeh STANDARD PREVIEW
(standards.iteh.ai)

[ISO 10322-2:1991](https://standards.iteh.ai/catalog/standards/sist/42e67366-49f3-48a0-bc4c-71fa5a7bef8b/iso-10322-2-1991)

<https://standards.iteh.ai/catalog/standards/sist/42e67366-49f3-48a0-bc4c-71fa5a7bef8b/iso-10322-2-1991>

iTeh STANDARD PREVIEW
(standards.iteh.ai)

ISO 10322-2:1991

<https://standards.iteh.ai/catalog/standards/sist/42e67366-49b-48a0-bc4c-71fa5a7bef8b/iso-10322-2-1991>