



SLOVENSKI STANDARD
SIST ISO 10370:1995

01-november-1995

BUZb]dfc]nj cX]!'8 c`c Ub^Y_c_gbY[UcghUb_U!'A]_fc`a YrcXU

Petroleum products -- Determination of carbon residue -- Micro method

Produits pétroliers -- Détermination du résidu de carbone -- Méthode micro

Ta slovenski standard je istoveten z: ISO 10370:1993

[SIST ISO 10370:1995](https://standards.iteh.ai/catalog/standards/sist/cccd8ec4-94f8-4d0a-9c12-8dc587f8dcf0/sist-iso-10370-1995)

<https://standards.iteh.ai/catalog/standards/sist/cccd8ec4-94f8-4d0a-9c12-8dc587f8dcf0/sist-iso-10370-1995>

ICS:

75.080	Naftni proizvodi na splošno	Petroleum products in general
--------	-----------------------------	-------------------------------

SIST ISO 10370:1995

en

iTeh STANDARD PREVIEW
(standards.iteh.ai)

SIST ISO 10370:1995

<https://standards.iteh.ai/catalog/standards/sist/cccd8ec4-94f8-4d0a-9c12-8dc587f8dcf0/sist-iso-10370-1995>

INTERNATIONAL
STANDARD

ISO
10370

First edition
1993-09-15

**Petroleum products — Determination of
carbon residue — Micro method**

iTeh STANDARD PREVIEW
*Produits pétroliers — Détermination du résidu de carbone — Méthode
micro*
(standards.iteh.ai)

SIST ISO 10370:1995

<https://standards.iteh.ai/catalog/standards/sist/cccd8ec4-94f8-4d0a-9c12-8dc587f8dcf0/sist-iso-10370-1995>



Reference number
ISO 10370:1993(E)

ISO 10370:1993(E)**Foreword**

ISO (the International Organization for Standardization) is a worldwide federation of national standards bodies (ISO member bodies). The work of preparing International Standards is normally carried out through ISO technical committees. Each member body interested in a subject for which a technical committee has been established has the right to be represented on that committee. International organizations, governmental and non-governmental, in liaison with ISO, also take part in the work. ISO collaborates closely with the International Electrotechnical Commission (IEC) on all matters of electrotechnical standardization.

Draft International Standards adopted by the technical committees are circulated to the member bodies for voting. Publication as an International Standard requires approval by at least 75 % of the member bodies casting a vote.

International Standard ISO 10370 was prepared by Technical Committee ISO/TC 28, *Petroleum products and lubricants*.

Annexes A and B of this International Standard are for information only.

ITEH STANDARD PREVIEW
(standards.iteh.ai)
SIST ISO 10370:1995
International Standard for information only
ec4-94f8-4d0a-9c12-8dc587f8dcf0/sist-iso-10370-1995

© ISO 1993

All rights reserved. No part of this publication may be reproduced or utilized in any form or by any means, electronic or mechanical, including photocopying and microfilm, without permission in writing from the publisher.

International Organization for Standardization
Case Postale 56 • CH-1211 Genève 20 • Switzerland

Printed in Switzerland

Petroleum products — Determination of carbon residue — Micro method

WARNING — The use of this International Standard may involve hazardous materials, operations and equipment. This International Standard does not purport to address all of the safety problems associated with its use. It is the responsibility of the user of this International Standard to establish appropriate safety and health practices and determine the applicability of regulatory limitations prior to use.

1 Scope

This International Standard specifies a method for the determination of the amount of carbon residue, in the range 0,10 % (*m/m*) to 30,0 % (*m/m*), left after evaporation and pyrolysis of petroleum products under specified conditions. For products which yield a residue in excess of 0,10 % (*m/m*), the test results are equivalent to those obtained by the Conradson carbon residue test (see ISO 6615).

This International Standard is also applicable to petroleum products which consist essentially of distillate material, and which may yield a carbon residue below 0,10 % (*m/m*). On such materials, a 10 % (*V/V*) distillation residue is prepared by the procedure described in ISO 3405 before analysis.

Both ash-forming constituents, as defined by ISO 6245, and non-volatile additives present in the sample add to the carbon residue value and are included in the total value reported.

NOTES

1 The carbon residue value serves as an approximation of the tendency of petroleum products to form carbonaceous deposits under similar degradation conditions, and can be useful in the assessment of relative carbon-forming tendencies of products within the same class. Care should be taken in the interpretation of results.

2 The presence of organic nitrates incorporated in certain distillate fuels will yield abnormally high values for the carbon residue. The presence of alkyl nitrate in the fuel may be detected by ASTM Test Method D 4046.

2 Normative reference

The following standard contains provisions which, through reference in this text, constitute provisions of this International Standard. At the time of publication, the edition indicated was valid. All standards are subject to revision, and parties to agreements based on this International Standard are encouraged to investigate the possibility of applying the most recent edition of the standard indicated below. Members of IEC and ISO maintain registers of currently valid International Standards.

ISO 3405:1988, *Petroleum products — Determination of distillation characteristics*.

3 Definition

For the purposes of this International Standard, the following definition applies.

3.1 carbon residue: The whole residue produced from the specific conditions of evaporation and pyrolysis described in this International Standard.

4 Principle

A weighed aliquot of the oil sample is placed in a glass vial and heated to 500 °C under an inert (nitrogen) gas stream in a controlled manner for a specific time. Volatiles formed during the reactions are swept away by the inert gas. The carbonaceous residue remaining is weighed.

ISO 10370:1993(E)

5 Reagents and materials

5.1 Nitrogen, oxygen-free, with appropriate regulation to provide a delivery pressure of 0 kPa to 200 kPa.

NOTE 3 The practical minimum delivery pressure is 140 kPa.

6 Apparatus

6.1 Glass sample vials, of 2 ml capacity, 12 mm outside diameter, approximately 35 mm high.

NOTE 4 A vial of 4 ml capacity, 12 mm outside diameter, approximately 72 mm high is available for use with samples of very low carbon residue content [below approximately 0,20 % (*m/m*)]. No precision data has been obtained with these vials.

6.2 Eyedropper or small rod, suitable for sample transfer.

6.3 Coking oven, comprising a circular heating chamber approximately 85 mm diameter by 100 mm deep for top-loading, capable of heating to 500 °C at a rate of between 10 °C and 40 °C per min, with exhaust port of 13 mm inside diameter for nitrogen purge of oven chamber (inlet near top, exhaust at bottom centre), with thermocouple sensor located in oven chamber next to but not touching sample vials, and with lid capable of sealing out air. The condensate outlet leads into a short vertical section where most of the vapour condenses and falls into a removable trap located directly below the oven. A schematic diagram is given in figure 1.

6.4 Sample vial holder, comprising a cylindrical aluminium block approximately 76 mm diameter by 17 mm thick with 12 evenly spaced holes (for vials) each 13 mm diameter by 13 mm deep. The holes shall be arranged in a circular pattern approximately 3 mm from the perimeter. The holder shall have legs 6 mm long with guides to centre in the oven chamber, and an index mark on the side to use as position reference. A typical holder is shown in figure 2.

6.5 Thermocouple, iron-constantan, with exterior read-out and a range including 450 °C to 550 °C.

6.6 Analytical balance, of 0,1 mg sensitivity.

6.7 Cooling vessel: desiccator or similar tightly closed vessel, without desiccant.

7 Sample preparation

7.1 For samples which consist essentially of distillate material, either follow the procedure given in 7.2 to 9.4 or prepare a distillation residue following a modified procedure of ISO 3405, given in 7.1.1 and 7.1.2.

7.1.1 Assemble the apparatus as directed in ISO 3405 but omit placing the thermometer in the neck of the distillation flask. Secure the neck of the flask with a snug-fitting, well-rolled cork or silicone rubber stopper.

NOTE 5 A thermometer is not required, as it is the volume of distillate collected that is critical, not the temperature of distillation.

7.1.2 Discontinue heating when 89 ml of distillate has been collected in the receiver. When 90 ml has been recovered, remove the receiver and replace with a small flask. Collect the remainder of the drainings from the condenser and combine with the warm residue from the distillation flask. This combined residue represents a 10 % (V/V) bottom portion of the original sample; use it in place of the sample as described in 7.2 to 9.4.

7.2 Thoroughly stir the sample to be tested, first warming if necessary to reduce its viscosity. If the samples are in liquid form transfer directly to the vials using a rod or syringe. If the samples are solid materials they shall either be heated, or frozen with liquid nitrogen and then shattered to provide manageable pieces.

8 Sample transfer

8.1 During weighing and filling, handle the vials with forceps to minimize weighing errors. Discard the vials after use.

8.2 Weigh the clean sample vials, and record the mass to the nearest 0,1 mg.

Dimensions in millimetres

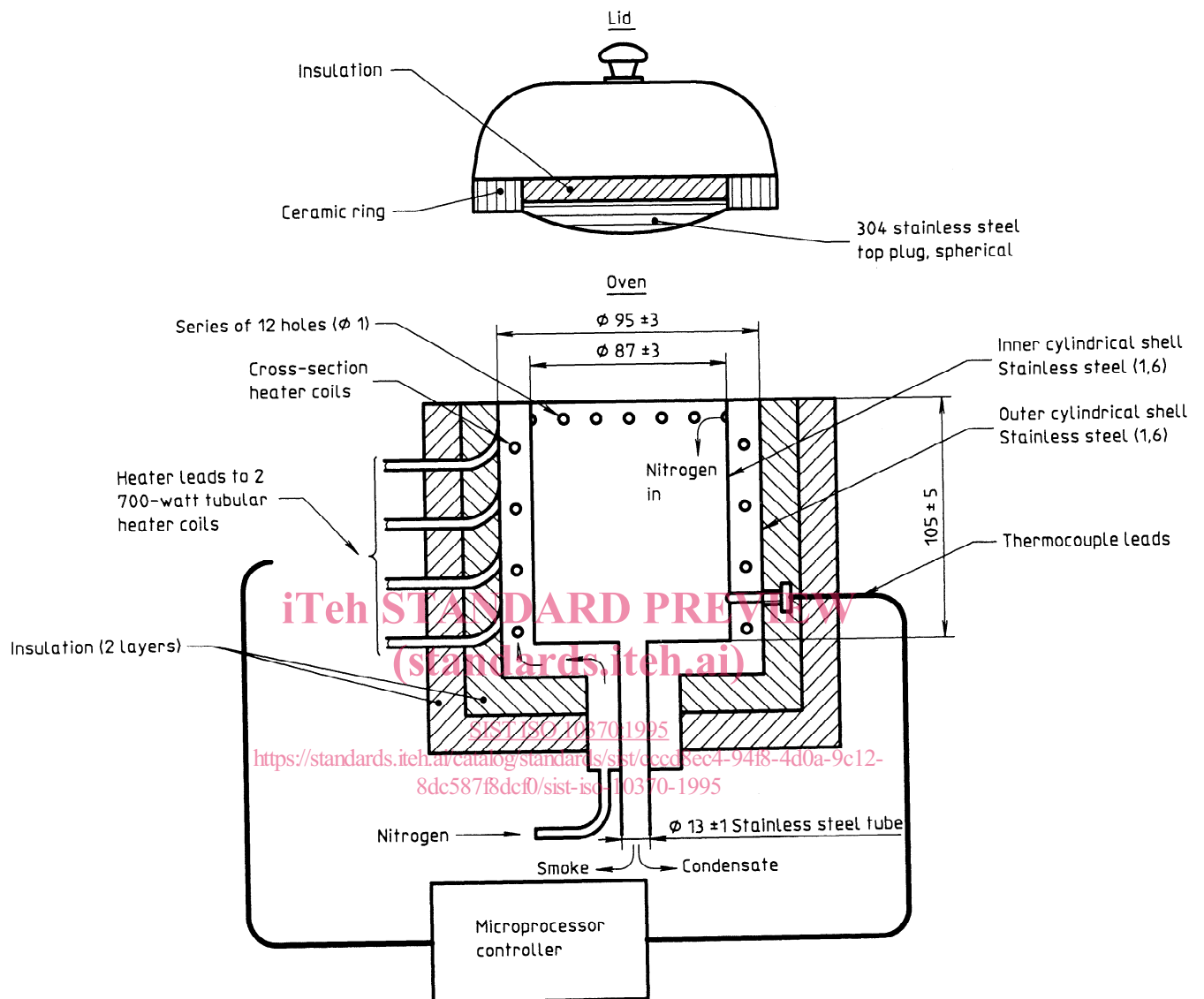
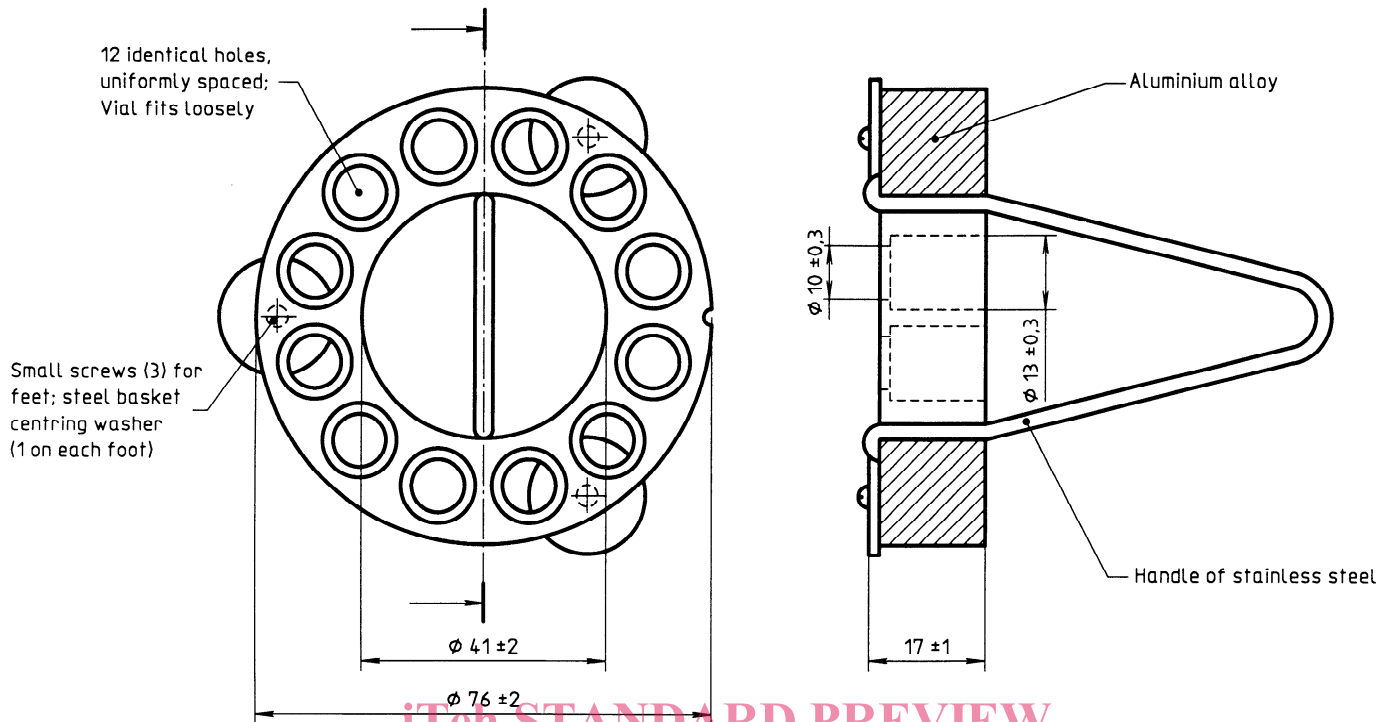

Figure 1 — Oven and lid

Dimensions in millimetres

Vial holder



iteh STANDARD PREVIEW
(standards.iteh.ai)

Vial

Soda Lime glass

SIST ISO 10370:1995

<https://standards.iteh.ai/catalog/standards/sist/cccd8ec4-94f8-4d0a-9c12-8dd587f8dc00/sist-iso-10370-1995>

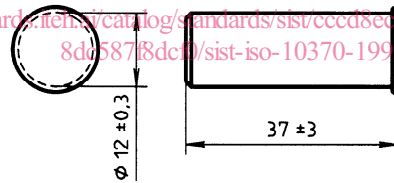

Figure 2 — Sample vial and vial holder

8.3 Transfer an appropriate mass of the sample (table 1) into the bottom of a tared sample vial, taking care to avoid contact between the sample and the vial wall, reweigh to the nearest 0,1 mg and record. Place the loaded sample vials into the vial holder (up to 12), noting the position of each sample with respect to the index mark.

NOTE 6 A control sample may be included in each batch of samples being tested. This control sample should be a typical sample which has been tested at least 20 times in the same equipment in order to define an average percent carbon residue and standard deviation.

Results for each batch are deemed acceptable when results for the control sample fall within the average percent carbon residue plus/minus three standard deviations. Control results which are outside these limits indicate problems with the procedure or the equipment.

Table 1 — Sample size

Sample description	Expected carbon residue % (m/m)	Sample size g
Black viscous, or solid	> 5,0	0,15 ± 0,05
Brown or black opaque and mobile	1,0 to 5,0	0,50 ± 0,10
Transparent or translucent	0,2 to 1,0 < 0,2	1,50 ± 0,50 1,50 ± 0,50 or 3,00 ± 0,50 when used in conjunction with the larger vial (see note 4)

9 Test procedure

9.1 With the oven at a temperature < 100 °C, place the vial holder, loaded as in 8.3, into the oven chamber and secure lid. Purge with nitrogen for at least 10 min at 600 ml/min. Subsequently, decrease the purge to 150 ml/min and heat the oven slowly to 500 °C at a rate of 10 °C/min to 15 °C/min.

9.2 Hold the oven at 500 °C ± 2 °C for 15 min. Then shut off furnace power and allow the oven to cool freely while under a nitrogen purge of 600 ml/min. When the oven temperature is < 250 °C, remove the vial holder for further cooling in the desiccator.

NOTE 7 After the samples are removed from the oven, the nitrogen purge may be shut off.

If the sample foams or spatters causing loss of sample, discard and repeat the test.

NOTE 8 Spattering may be due to water that can be removed by prior gentle heating under reduced pressure, followed by a nitrogen sweep. Alternatively, a smaller size can be used.

If another test is to be run, remove the lid to allow faster cooling.

NOTE 9 A subsequent test can be started when the oven has cooled to below 100 °C.

WARNING — Do not open the oven to air at any time during the heating cycle, as the introduction of air (oxygen) may form an explosive mixture with the volatile coking products formed. Do not open the oven until the oven temperature has fallen to below 250 °C during the cooling step. Maintain the nitrogen flow until after the vial holder has been removed from the oven.

Either locate the coking oven in a laboratory exhaust hood for safe venting of smoke and fumes, or install a vent line from the oven exhaust to the laboratory exhaust system, being careful not to create negative pressure in the line.

9.3 Handling the vials with forceps, transfer them to the desiccator and allow them to cool to room temperature. Weigh each cooled vial to the nearest 0,1 mg and record its mass. Discard the used glass sample vials.

9.4 Occasionally examine the condensate trap at the bottom of the oven chamber; empty if necessary and replace.

WARNING — The condensate trap residue may contain some carcinogenic materials, and contact with them should be avoided. They should be properly disposed of according to acceptable procedures.

10 Calculation

Calculate the mass percentage of carbon residue in the original sample, or in the 10 % (V/V) distillation residue, to the nearest 0,01 % (m/m), using equation (1).

$$\text{Carbon residue, \% (m/m)} = \frac{m_3 - m_1}{m_2 - m_1} \times 100 \dots (1)$$

where

m_1 is the mass of the empty vial, in grams;

m_2 is the mass of vial + test portion, in grams;

m_3 is the mass of vial + residue, in grams.