



## Standard Test Method for Determining the Actuation Force and Contact Force of a Membrane Switch<sup>1</sup>

This standard is issued under the fixed designation F 1597; the number immediately following the designation indicates the year of original adoption or, in the case of revision, the year of last revision. A number in parentheses indicates the year of last reappraisal. A superscript epsilon (ε) indicates an editorial change since the last revision or reappraisal.

### 1. Scope

1.1 This test method covers the measurement of actuation force or contact force, or both, of a membrane switch utilizing a pre-determined resistance value.

1.2 *This standard does not purport to address all of the safety concerns, if any, associated with its use. It is the responsibility of the user of this standard to establish appropriate safety and health practices and determine the applicability of regulatory limitations prior to use.*

### 2. Referenced Documents

2.1 *ASTM Standards:*

D 2240 Test Method for Rubber Property-Durometer Hardness<sup>2</sup>

F 1570 Test Method for Determining the Tactile Ratio of a Membrane Switch<sup>3</sup>

### 3. Terminology

3.1 *Definitions:*

3.1.1 *actuation force (Fa)*—the maximum force measure prior to or including point at which contact closure is achieved on a membrane switch.

3.1.2 *contact closure (make)*—the event at which a specified resistance is achieved.

3.1.3 *contact force (Fc)*—the force at contact closure.

3.1.4 *membrane switch*—a momentary switching device in which at least one contact is on, or made of, a flexible substrate.

3.1.5 *non-tactile switch*—a switch assembly that has a tactile ratio equal to zero (see Test Method F 1570).

3.1.6 *specified resistance*—maximum allowable resistance as measured between two terminations whose internal switch contacts are held closed to complete a circuit.

3.1.7 *tactile switch*—a switch assembly that provides a tactile ratio greater than zero (see Test Method F 1570).

### 4. Significance and Use

4.1 Specified resistance is useful to manufacturers and users when designing membrane switch interface circuitry.

4.2 Actuation force and contact force are useful to manufacturers and users in determining the suitability, preference and aesthetics of a membrane switch in a given application.

### 5. Apparatus

5.1 *Test Probe*—Test probes that do not meet the following criteria must be fully specified and recorded. Do not change probe type throughout the duration of the test.

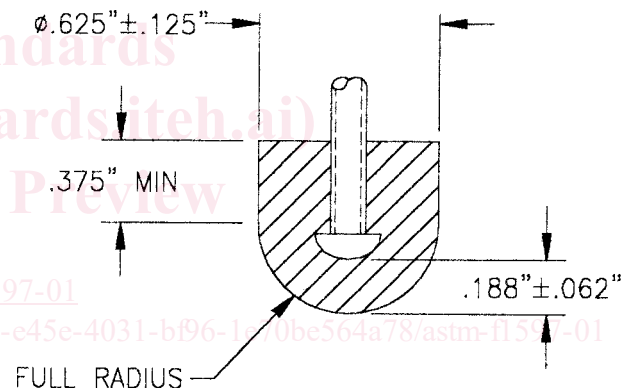

FIG. 1 Test Probe Option

Switch to be measured	Material	Size and Shape
Tactile switch	Non-elastic	To be specified
Non-tactile switch	Inert elastomeric material Hardness = A/45 ± 5 per Test Method D 2240	Fig. 1 or Fig. 2 or specified

5.2 *Test Surface*, flat, smooth, unyielding and larger than switch under test.

5.3 *Device*, to hold test probe securely and provide perpendicular movement into and away from switch under test.

5.4 *Resistance Measuring Device*, that is, Ohm meter. The device should not apply a voltage outside the operating range of the switch contacts.

5.5 *Suitable Monitoring Device*, to measure force on test probe.

### 6. Procedure

6.1 *Pre-Test Setup:*

<sup>1</sup> This test method is under the jurisdiction of ASTM Committee F01 on Electronics and is the direct responsibility of Subcommittee F01.18 on Membrane Switches.

Current edition approved June 10, 2001. Published August 2001. Originally published as F 1597-95. Last previous edition F 1597-00.

<sup>2</sup> *Annual Book of ASTM Standards*, Vol. 09.01.

<sup>3</sup> *Annual Book of ASTM Standards*, Vol. 10.05.