



Standard Test Method for Open Channel Flow Measurement of Water with the Parshall Flume¹

This standard is issued under the fixed designation D 1941; the number immediately following the designation indicates the year of original adoption or, in the case of revision, the year of last revision. A number in parentheses indicates the year of last reapproval. A superscript epsilon (ϵ) indicates an editorial change since the last revision or reapproval.

1. Scope

1.1 This test method covers measurement of the volumetric flowrate of water and wastewater in open channels with the Parshall flume.

1.1.1 Information related to this test method can be found in ISO 1438 and 4359.

1.2 *This standard does not purport to address all of the safety concerns, if any, associated with its use. It is the responsibility of the user of this standard to establish appropriate safety and health practices and determine the applicability of regulatory limitations prior to use.*

2. Referenced Documents

2.1 ASTM Standards:

D 1129 Terminology Relating to Water²

D 2777 Practice for Determination of Precision and Bias of Applicable Methods of Committee D-19 on Water²

D 3858 Test Method for Open Channel Flow Measurement of Water by Velocity-Area Method²

2.2 ISO Standards:

ISO 555 Liquid Flow Measurements in Open Channels—Dilution Methods for Measurement of Steady Flow—Constant Rate Injection Method³

ISO 1438 Liquid Flow Measurement in Open Channels Using Thin-Plate Weirs and Venturi Flumes³

ISO 4359 Liquid Flow Measurement in Open Channels—Rectangular Trapezoidal and U-shaped Flumes³

3. Terminology

3.1 *Definitions:* For definitions of terms used in this test method, refer to Terminology D 1129.

3.2 Definitions of Terms Specific to This Standard:

3.2.1 *free flow*—a condition where the flowrate is governed by the state of flow at the crest overfall and hence can be determined from a single upstream depth measurement.

3.2.2 *head*—the height of a liquid above a specified point;

that is, the flume crest.

3.2.3 *hydraulic jump*—an abrupt transition from supercritical to subcritical flow, accompanied by considerable turbulence or gravity waves, or both.

3.2.4 *normal depth*—the uniform depth of flow for a given flowrate in a long open channel of specific shape, roughness, and slope.

3.2.5 *primary instrument*—the device (in this case, the flume) that creates a hydrodynamic condition that can be sensed by the secondary instrument.

3.2.6 *scow float*—an in-stream flat for depth sensing usually mounted on a hinged cantilever.

3.2.7 *secondary instrument*—in this case, a device which measures the depth of flow at an appropriate location in the flume. The secondary instrument may also convert the measured depth to an indicated flow rate.

3.2.8 *stilling well*—a small reservoir connected through a constricted passage to the main channel, that is, the flume, so that a depth measurement can be made under quiescent conditions.

3.2.9 *subcritical flow*—open channel flow at a velocity less than the velocity of gravity waves in the same depth of water. Subcritical flow is affected by downstream conditions, since disturbances are able to travel upstream.

3.2.10 *submerged flow*—a condition where the water stage downstream of the flume is sufficiently high to affect the flow over the flume crest and hence the free-flow depth-discharge relation no longer applies and discharge depends on two head measurements.

3.2.11 *supercritical flow*—open channel flow at a velocity greater than that of gravity waves in the same depth, so disturbances cannot travel upstream, and downstream conditions do not affect the flow.

3.2.12 *throat*—the constriction in a flume.

4. Summary of Test Method

4.1 Parshall flumes are measuring flumes of specified geometries for which empirical relations of the form

$$Q = C H_a^n \quad (1)$$

have been established so that the flowrate, Q , can be determined from a single depth measurement, H_a , in free flow. If the flow is submerged, an addition downstream depth, H_b , must be measured and suitable adjustments made.

¹ This test method is under the jurisdiction of ASTM Committee D-19 on Water and is the direct responsibility of Subcommittee D19.07 on Sediments, Geomorphology, and Open-Channel Flow.

Current edition approved Jan. 25, 1991. Published March 1991. Originally published in 1962. Last previous edition D 1941 – 67 (1975) ϵ^2 .

² *Annual Book of ASTM Standards*, Vol 11.01.

³ Available from American National Standards Institute, 11 W. 42nd St., 13th Floor, New York, NY 10036.

5. Significance and Use

5.1 Flume designs are available for throat sizes of 1 in. (2.54 cm) to 50 ft (15.2 m) which cover maximum flows of 0.2 to 3000 ft³/s (0.0057 to 85 m³/s) (1) and (2)⁴. They can therefore be applied to a wide range of flows, with head losses that are moderate.

5.2 The flume is self-cleansing for moderate solids transport and therefore is suited for wastewater and flows with sediment.

6. Interferences

6.1 The flume is applicable only to open channel flow and is inoperative under full-pipe flow conditions.

6.2 Although the flume has substantial self-cleansing capacity, it can be clogged by debris or affected by accumulation of aquatic growth and cleaning or debris removal may be required.

7. Apparatus

7.1 A Parshall flume measuring system consists of the flume itself (primary) and a depth-measuring device (secondary). The secondary device can range from a simple scale for manual readings to an instrument which continuously senses the depth, converts it to flowrate, and provides a readout or record of instantaneous flowrate or totalized flow, or both.

7.2 The Flume:

7.2.1 Parshall flumes are characterized by throat width; dimensions and flowrates for each size are given in Fig. 1 and Table 1, respectively. The dimensions must be maintained within 2 %, because the flume is an empirical device and corrections for non-standard geometry are only estimates. The inside surface of the flume should be at least as smooth as a good quality concrete finish.

7.2.2 The measurement location for depth H_a is shown in Fig. 1. In submerged flow a second depth, H_b , must be

⁴ The boldface numbers in parentheses refer to a list of references at the end of this test method.

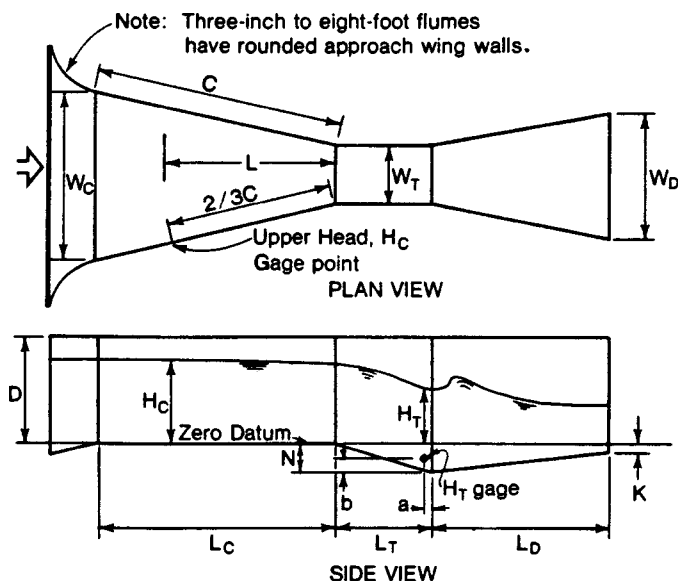

FIG. 1 Parshall Flume

measured in the throat as indicated. However, in the 1, 2, and 3-in. (2.54, 5.08, and 7.62-cm) flumes, this measurement is made at H_c instead, because disturbances have been observed at the H_b location in these sizes ((1) and (2)). See Fig. 2 for the relation between H_b and H_c .

7.3 Stilling Well and Connector:

7.3.1 Stilling wells are recommended for accurate depth measurements; they are required when wire- or tape-supported cylindrical floats are used or when the liquid surface is fluctuating.

7.3.2 The lateral area of the stilling well is governed in part by the requirements of the depth sensor. For example, the clearance between a float and the stilling-well wall should be at least 0.1 ft (3 cm) and should be increased to 0.25 ft (7.6 cm) if the well is made of concrete or other rough material, the float diameter itself being determined in part by permissible float lag error (see 11.4.2). Other types of depth sensors may also impose size requirements on the stilling well, and the maximum size may be limited by response lag.

7.3.3 Provision should be made for cleaning and flushing the stilling well to remove accumulated solids. It may be necessary to add a small purge flow of tap water to help keep the well and any connector pipe and the sensor parts clean. This flow should be small enough for any depth increase in the stilling well to be imperceptible.

7.3.4 The opening in the flume sidewall connecting to the stilling well either directly or through a short perpendicular pipe must have a burr-free junction with the wall. The hole or pipe must be small enough to dampen surface disturbances; an area of about 1/1000th of the stilling-well area is considered adequate for this purpose. However, the diameter should not be so small (or the pipe so long) that it is difficult to keep open or a lag is introduced in the response to changing flows (3); hole and pipe diameters of about 1/2 in. (1.3 cm) should be considered a minimum. If changes are made in pipe sizes, they should be done sufficiently removed from the flume wall that no drawdown will occur. The intake dimensions cited in this paragraph should be regarded as suggestions only.

7.4 Depth-Discharge Relations:

7.4.1 Free Flow—The values of C and n for use with Eq. 1 are given in Table 2, along with approximate limiting flowrates. The maximum submergence ratios, H_b/H_a , for which free flow will occur are:

$H_b/H_a < 0.5$, for 1, 2, and 3-in. (2.54, 5.08, and 7.62-cm) flumes;

$H_b/H_a < 0.6$, for 6 and 9-in. (15.24 and 22.86-cm) flumes;

$H_b/H_a < 0.7$, for 1 to 8-ft (30.48 to 243.8-cm) flumes;

$H_b/H_a < 0.8$, for 10 to 50-ft (304.8 to 1524.0-cm) flumes.

7.4.2 Submerged Flow:

7.4.2.1 Discharge rates for submerged-flow conditions are given for 1, 2, 3, 6, and 9-in. (2.54, 5.08, 7.62, 15.24, and 22.86-cm) flumes in Table 3, Table 4, Table 5, Table 6, and Table 7 (Table 8, Table 9, Table 10, Table 11, and Table 12), which were compiled from published curves (2).

7.4.2.2 For all larger flumes, that is, 1 to 50 ft (30.48 to 1524 cm) throat widths, flowrates under submerged-flow conditions are given as corrections to be subtracted from the free-flow discharge at the same H_a . These corrections are found in Table

TABLE 1 Dimensions and Capacities of Standard Parshall Flumes

NOTE 1—Flume sizes 3 in. through 8 ft have approach aprons rising at 25 % slope and the following entrance roundings: 3 through 9 in., radius = 1.33 ft; 1 through 3 ft, radius = 1.67 ft; 4 through 8 ft, radius = 2.00 ft.

Throat, W_T	Widths		Axial lengths, ft			Wall Depth in Con-verging Section, D , ft	Vertical distance below crest, ft		Converging wall length C^A , ft	Gage Points, ft			Free-flow Capacities, ft^3/s	
	Upstream end, W_C , ft	Down-stream end, W_D , ft	Converging Section, L_C	Throat section, L_T	Diverging section, L_D		Dip at Throat, N	Lower end of flume, K		H_T			Minimum	Maximum
										H_C , wall length upstream of crest ^B	a	b		
1 in.	0.549	0.305	1.17	0.250	0.67	0.5–0.75	0.094	0.062	1.19	0.79	0.026	0.042	0.005	0.15
2 in.	0.700	0.443	1.33	0.375	0.83	0.50–0.83	0.141	0.073	1.36	0.91	0.052	0.083	0.01	0.30
3 in.	0.849	0.583	1.50	0.500	1.00	1.00–2.00	0.188	0.083	1.53	1.02	0.083	0.125	0.03	1.90
6 in.	1.30	1.29	2.00	1.00	2.00	2.0	0.375	0.25	2.36	1.36	0.167	0.25	0.05	3.90
9 in.	1.88	1.25	2.83	1.00	1.50	2.5	0.375	0.25	2.88	1.93	0.167	0.25	0.09	8.90
1.0 ft	2.77	2.00	4.41	2.0	3.0	3.0	0.75	0.25	4.50	3.00	0.167	0.25	0.11	16.1
1.5 ft	3.36	2.50	4.66	2.0	3.0	3.0	0.75	0.25	4.75	3.17	0.167	0.25	0.15	24.6
2.0 ft	3.96	3.00	4.91	2.0	3.0	3.0	0.75	0.25	5.00	3.33	0.167	0.25	0.42	33.1
3.0 ft	5.16	4.00	5.40	2.0	3.0	3.0	0.75	0.25	5.50	3.67	0.167	0.25	0.61	50.4
4.0 ft	6.35	5.00	5.88	2.0	3.0	3.0	0.75	0.25	6.00	4.00	0.167	0.25	1.30	67.9
5.0 ft	7.55	6.00	6.38	2.0	3.0	3.0	0.75	0.25	6.50	4.33	0.167	0.25	1.60	85.6
6.0 ft	8.75	7.00	6.86	2.0	3.0	3.0	0.75	0.25	7.0	4.67	0.167	0.25	2.60	103.5
7.0 ft	9.95	8.00	7.35	2.0	3.0	3.0	0.75	0.25	7.5	5.0	0.167	0.25	3.00	121.4
8.0 ft	11.15	9.00	7.84	2.0	3.0	3.0	0.75	0.25	8.0	5.33	0.167	0.25	3.50	139.5
10 ft	15.60	12.00	14.0	3.0	6.0	4.0	1.12	0.50	9.0	6.00	6	300
12 ft	18.40	14.67	16.0	3.0	8.0	5.0	1.12	0.50	10.0	6.67	8	520
15 ft	25.0	18.33	25.0	4.0	10.0	6.0	1.50	0.75	11.5	7.67	8	900
20 ft	30.0	24.00	25.0	6.0	12.0	7.0	2.25	1.00	14.0	9.33	10	1340
25 ft	35.0	29.33	25.0	6.0	13.0	7.0	2.25	1.00	16.5	11.00	15	1660
30 ft	40.4	34.67	26.0	6.0	14.0	7.0	2.25	1.00	19.0	12.67	15	1990
40 ft	50.8	45.33	27.0	6.0	16.0	7.0	2.25	1.00	24.0	16.00	20	2640
50 ft	60.8	56.67	27.0	6.0	20.0	7.0	2.25	1.00	29.0	19.33	25	3280

^AFor sizes 1 to 8 ft, $C = W_T/2 + 4$ ft.

^B H_C located $2/3$ C distance from crest for all sizes; distance is wall length, not axial.

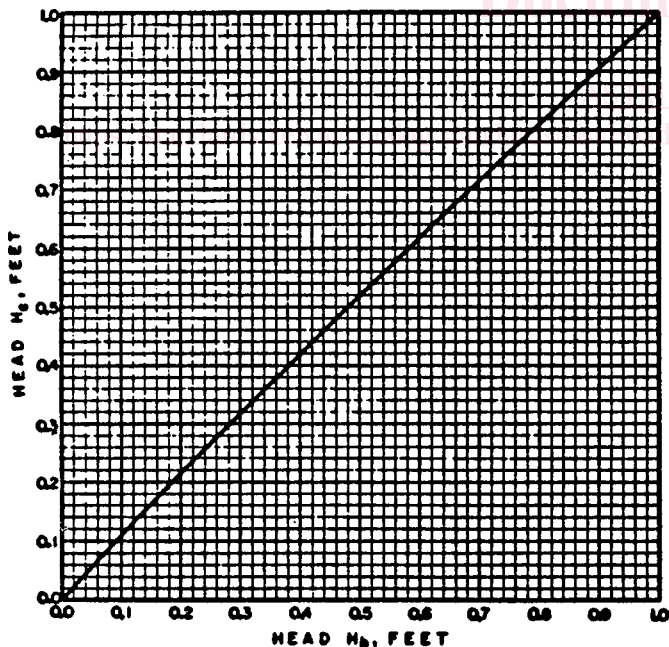

NOTE 1—1 ft = 30.48 cm

FIG. 2 Relation Between H_b and H_c for 1, 2, and 3-in. (2.54, 5.08, and 7.62-cm) flumes (Reference (2))

TABLE 2 Free-Flow Values of C and n for Parshall Flumes (See Eq. 1)

Throat Width		C^A			n	Q , min ^B		Q , max ^B	
ft-in	cm	inch-pound	SI	ft^3/s		$\text{m}^3 \times 10^3/\text{s}$	ft^3/s	m^3/s	
0-1	2.54	0.338	0.0479	1.55	0.01	0.28	0.2	0.0057	
0-2	5.08	0.676	0.0959	1.55	0.02	0.56	0.5	0.014	
0-3	7.62	0.992	0.141	1.55	0.03	0.85	1.1	0.031	
0-6	15.24	2.06	0.264	1.58	0.05	1.42	3.9	0.11	
0-9	22.80	3.07	0.393	1.53	0.09	2.55	8.9	0.25	
1-0	30.48	4.00	0.624	1.522	0.11	3.1	16.1	0.46	
1-6	45.72	6.00	0.887	1.538	0.15	4.2	24.6	0.69	
2-0	60.96	8.00	1.135	1.550	0.42	11.9	38.1	0.93	
3-0	91.44	12.00	1.612	1.566	0.61	17.3	50.4	1.42	
4-0	121.92	16.00	2.062	1.578	1.3	36.8	67.9	1.92	
5-0	152.40	20.00	2.500	1.587	1.6	45.3	85.6	2.42	
6-0	182.88	24.00	2.919	1.595	2.6	73.6	103.5	2.93	
7-0	213.36	28.00	3.337	1.601	3.0	85.0	121.4	3.44	
8-0	243.84	32.00	3.736	1.607	3.5	99.1	139.5	3.95	
10-0	304.8	39.38	4.709	1.6	6	170	200	5.6	
12-0	365.8	46.75	5.590	1.6	8	227	350	9.9	
19-0	457.2	57.81	6.912	1.6	8	227	600	17.0	
20-0	609.6	76.25	9.117	1.6	10	283	1000	28.3	
25-0	762.0	94.69	11.32	1.6	15	425	1200	34.0	
30-0	914.4	113.13	13.53	1.6	15	425	1500	42.5	
40-0	1219.2	150.00	17.94	1.6	20	566	2000	56.6	
50-0	1524.0	186.88	22.35	1.6	25	708	3000	84.9	

^AListed values of C should be used in Eq. 1 with H_a in feet to obtain flowrate in cubic feet per second. Listed values of C (metric) should be used with H_a in centimetres to obtain flowrate in litres per second.

^BFrom Ref (1).

13, Table 14, Table 15, and Table 16 (Table 17, Table 14, Table 18, and Table 16), which were compiled from published curves (2).

7.4.2.3 It is recommended that submergence be avoided if possible and that ratios not be allowed to exceed 0.95.

TABLE 3 Flume, 1-in. (2.54-cm), Submerged—Flowrate, ft³/s

Submerged, %	H_a , ft															
	0.05	0.06	0.08	0.10	0.15	0.20	0.25	0.30	0.35	0.40	0.45	0.50	0.55	0.60	0.70	0.80
50	0.0033	0.0044	0.0067	0.0095	0.0180	0.028	0.039	0.052	0.066	0.082	0.097
55	0.0032	0.0043	0.0066	0.0094	0.0180	0.028	0.038	0.052	0.065	0.081	0.096
60	0.0032	0.0042	0.0065	0.0093	0.0179	0.027	0.038	0.051	0.064	0.079	0.094
65	0.0031	0.0041	0.0064	0.0090	0.0173	0.026	0.037	0.050	0.061	0.076	0.091
70	0.0030	0.0040	0.0062	0.0087	0.0165	0.025	0.035	0.047	0.058	0.072	0.087
75	...	0.0038	0.0059	0.0083	0.0156	0.024	0.033	0.044	0.055	0.068	0.081	0.096
80	...	0.0036	0.0055	0.0077	0.0145	0.022	0.031	0.040	0.051	0.063	0.074	0.088	0.100
85	...	0.0032	0.0050	0.0069	0.0130	0.020	0.028	0.036	0.045	0.056	0.066	0.077	0.090	0.100
90	0.0042	0.0060	0.0112	0.017	0.024	0.031	0.038	0.046	0.055	0.064	0.074	0.083
95	0.0034	0.0048	0.0089	0.014	0.018	0.024	0.030	0.037	0.042	0.050	0.056	0.062	0.075	0.090

TABLE 4 Flume, 2-in. (5.08-cm), Submerged—Flowrate, ft³/s

Submerged, %	H_a , ft															
	0.06	0.10	0.15	0.20	0.25	0.30	0.35	0.40	0.45	0.50	0.55	0.60	0.70	0.80	0.90	1.00
50	0.0086	0.0189	0.0350	0.0554	0.080	0.103	0.137	0.165	0.200	0.230	0.271	0.314
55	0.0086	0.0188	0.0350	0.0550	0.079	0.103	0.136	0.163	0.198	0.229	0.270	0.314	0.382
60	0.0085	0.0185	0.0345	0.0549	0.078	0.102	0.134	0.161	0.194	0.226	0.268	0.312	0.377
65	0.0083	0.0182	0.0340	0.0534	0.077	0.101	0.132	0.158	0.190	0.223	0.263	0.307	0.371
70	0.0080	0.0175	0.0332	0.0520	0.075	0.098	0.129	0.154	0.186	0.216	0.254	0.296	0.361
75	0.0077	0.0164	0.0312	0.0498	0.072	0.093	0.123	0.148	0.179	0.207	0.242	0.282	0.344
80	0.0071	0.0152	0.0289	0.0458	0.067	0.087	0.114	0.139	0.167	0.193	0.228	0.261	0.326	0.396
85	...	0.0138	0.0258	0.0409	0.060	0.080	0.101	0.126	0.151	0.176	0.203	0.235	0.300	0.358
90	...	0.0117	0.0212	0.0346	0.049	0.067	0.087	0.104	0.129	0.150	0.177	0.200	0.259	0.315	0.369	...
95	...	0.0088	0.0158	0.0244	0.035	0.047	0.064	0.078	0.092	0.111	0.130	0.150	0.198	0.250	0.300	0.350

TABLE 5 Flume, 3-in. (7.62-cm), Submerged—Flowrate, ft³/s

Submerged, %	H_a , ft																	
	0.12	0.16	0.20	0.25	0.30	0.35	0.40	0.45	0.50	0.55	0.60	0.70	0.80	0.90	1.0	1.2	1.4	1.6
50	0.037	0.057	0.082	0.117	0.156	0.195	0.240	0.287	0.335	0.397	0.450	0.562	0.700	0.841	0.977	1.31
55	0.037	0.057	0.082	0.117	0.156	0.194	0.239	0.286	0.334	0.394	0.448	0.561	0.696	0.836	0.974	1.31
60	0.037	0.057	0.082	0.116	0.155	0.192	0.238	0.285	0.333	0.390	0.443	0.559	0.686	0.826	0.967	1.29
65	0.037	0.057	0.082	0.115	0.154	0.191	0.236	0.282	0.331	0.383	0.436	0.557	0.680	0.817	0.958	1.27
70	0.036	0.056	0.080	0.113	0.150	0.188	0.230	0.277	0.325	0.374	0.425	0.545	0.665	0.800	0.935	1.25
75	0.036	0.055	0.077	0.108	0.144	0.182	0.221	0.264	0.312	0.359	0.408	0.520	0.642	0.763	0.900	1.19	1.49	...
80	0.034	0.052	0.073	0.101	0.136	0.171	0.206	0.247	0.293	0.339	0.383	0.488	0.604	0.712	0.841	1.12	1.41	...
85	0.031	0.047	0.066	0.092	0.123	0.153	0.188	0.223	0.263	0.309	0.350	0.439	0.545	0.651	0.758	1.00	1.28	...
90	...	0.041	0.057	0.081	0.104	0.134	0.163	0.192	0.225	0.264	0.304	0.379	0.465	0.562	0.653	0.853	1.09	1.33
95	...	0.033	0.045	0.062	0.081	0.098	0.125	0.148	0.174	0.198	0.228	0.290	0.355	0.422	0.500	0.648	0.815	0.988

7.5 Installation Requirements:

7.5.1 It is highly desirable that the Parshall flume installation be designed for free flow. The depth-discharge relations for free flow are more accurate than those for submerged flow, particularly at high submergence ratios. Further, the secondary instrumentation for free flow is simpler and more readily available. Design for free flow requires an estimate of the normal depth of flow in the channel downstream of the flume and the assumption that the resulting surface elevation prevails approximately at the H_b location. Design examples are available in the References.

7.5.2 The flow entering the flume should be tranquil and uniformly distributed across the channel. For this purpose, uniform velocity distribution can be defined as that associated with fully developed flow in a long, straight, moderately smooth channel. As a general guideline, a straight upstream approach length of 10 to 20 times the throat width will meet this entrance condition. The adequacy of the approach flow must be demonstrated on a case-by-case basis using current-meter traverses, experience with similar situations, or

analytical approximations.

7.5.3 If the approach flow is supercritical, the installation should be designed so that a hydraulic jump is formed at a distance upstream of at least $30 H_a$. If the existence of the hydraulic jump closer to the flume is unavoidable, the adequacy of the entering flow should be demonstrated as in 7.5.2.

7.5.4 The flume should be constructed and installed so that the floor of the converging section is level to within a slope not to exceed 0.01 ft in any dimension, or a re-rating is necessary.

7.6 Secondary Instrumentation:

7.6.1 A minimal secondary system for continuous monitoring would contain a depth-sensing device and a depth indicator or recorder from which the user could determine flowrates from the depth-discharge relations. Optionally, the secondary system could convert the measured depth to an indicated or recorded flowrate, or both, and totalized flow, and further could transmit the information electrically or pneumatically to a central location.

7.6.2 Continuous depth measurements can be made with

TABLE 6 Flume, 6-in. (15.24-cm), Submerged—Flowrate, ft³/s

Submerged, %	H_a , ft														
	0.1	0.2	0.3	0.4	0.5	0.6	0.7	0.8	0.9	1.0	1.1	1.2	1.3	1.4	1.5
60	0.050	0.162	0.300	0.462	0.655	0.870	1.12	1.40	1.70	2.00	2.34	2.68	3.03	3.38	3.77
62	0.050	0.160	0.297	0.458	0.651	0.865	1.12	1.39	1.67	1.98	2.32	2.65	3.00	3.36	3.74
64	0.050	0.158	0.291	0.455	0.646	0.859	1.11	1.38	1.66	1.96	2.29	2.63	2.97	3.33	3.71
66	0.050	0.156	0.287	0.452	0.639	0.854	1.10	1.37	1.64	1.94	2.26	2.60	2.94	3.30	3.67
68	0.050	0.154	0.285	0.445	0.633	0.849	1.09	1.35	1.63	1.93	2.24	2.56	2.90	3.26	3.64
70	0.050	0.152	0.283	0.440	0.624	0.839	1.07	1.34	1.60	1.90	2.20	2.53	2.85	3.22	3.60
72	0.050	0.150	0.278	0.432	0.617	0.828	1.06	1.33	1.57	1.86	2.16	2.49	2.80	3.17	3.54
74	0.050	0.147	0.274	0.424	0.607	0.817	1.04	1.30	1.54	1.83	2.13	2.44	2.75	3.11	3.47
76	0.050	0.144	0.270	0.414	0.593	0.802	1.02	1.26	1.52	1.80	2.09	2.39	2.70	3.04	3.40
78	0.050	0.141	0.263	0.402	0.580	0.782	1.00	1.23	1.47	1.75	2.04	2.33	2.64	2.97	3.32
80	0.048	0.137	0.252	0.389	0.564	0.764	0.97	1.20	1.44	1.70	1.97	2.26	2.56	2.89	3.22
82	0.045	0.131	0.243	0.377	0.540	0.741	0.94	1.16	1.40	1.65	1.90	2.19	2.48	2.80	3.10
84	0.042	0.125	0.235	0.356	0.520	0.709	0.90	1.12	1.34	1.59	1.83	2.11	2.39	2.68	2.99
86	0.040	0.121	0.224	0.342	0.498	0.674	0.87	1.07	1.29	1.52	1.75	2.02	2.29	2.56	2.85
88	0.038	0.115	0.211	0.322	0.471	0.638	0.82	1.02	1.23	1.44	1.67	1.92	2.17	2.44	2.72
90	0.035	0.106	0.196	0.300	0.438	0.593	0.76	0.95	1.15	1.36	1.57	1.80	2.04	2.30	2.55
92	0.030	0.100	0.175	0.278	0.402	0.544	0.70	0.88	1.07	1.26	1.47	1.67	1.91	2.14	2.38
94	0.028	0.088	0.155	0.250	0.359	0.487	0.64	0.80	0.97	1.15	1.35	1.54	1.74	1.95	2.17
95	0.025	0.083	0.145	0.230	0.330	0.453	0.60	0.75	0.86	1.03	1.21	1.45	1.64	1.85	2.06

TABLE 7 Flume, 9-in. (22.86-cm), Submerged—Flowrate, ft³/s

Submerged, %	H_a , ft														
	0.1	0.2	0.3	0.4	0.5	0.6	0.7	0.8	0.9	1.0	1.1	1.2	1.3	1.4	1.5
60	0.093	0.276	0.490	0.750	1.05	1.37	1.75	2.17	2.57	3.02	3.52	4.06	4.57	5.10	5.65
62	0.093	0.276	0.486	0.747	1.05	1.37	1.75	2.16	2.56	3.01	3.50	4.04	4.55	5.07	5.62
64	0.090	0.272	0.479	0.745	1.04	1.36	1.74	2.15	2.55	3.00	3.48	4.01	4.52	5.04	5.58
66	0.090	0.269	0.476	0.739	1.04	1.35	1.73	2.13	2.53	2.97	3.45	3.97	4.48	5.00	5.54
68	0.089	0.262	0.472	0.732	1.03	1.34	1.72	2.12	2.52	2.95	3.43	3.94	4.44	4.96	5.50
70	0.087	0.259	0.469	0.726	1.02	1.33	1.70	2.10	2.49	2.93	3.40	3.90	4.40	4.91	5.45
72	0.084	0.252	0.466	0.719	1.01	1.32	1.68	2.07	2.46	2.90	3.35	3.85	4.34	4.85	5.39
74	0.081	0.247	0.459	0.707	1.00	1.31	1.66	2.04	2.44	2.87	3.32	3.80	4.30	4.80	5.33
76	0.077	0.240	0.450	0.697	0.98	1.30	1.64	2.02	2.40	2.83	3.26	3.74	4.23	4.73	5.25
78	0.076	0.234	0.440	0.687	0.96	1.27	1.62	1.98	2.36	2.79	3.21	3.68	4.16	4.65	5.16
80	0.074	0.231	0.431	0.671	0.94	1.25	1.59	1.94	2.32	2.73	3.15	3.61	4.09	4.57	5.06
82	0.071	0.223	0.421	0.658	0.92	1.23	1.55	1.90	2.26	2.67	3.07	3.52	4.00	4.46	4.95
84	0.065	0.213	0.407	0.639	0.90	1.20	1.50	1.84	2.20	2.60	3.00	3.42	3.89	4.34	4.80
86	0.061	0.200	0.397	0.619	0.85	1.16	1.46	1.77	2.13	2.50	2.90	3.30	3.74	4.20	4.64
88	0.058	0.193	0.377	0.593	0.81	1.10	1.40	1.70	2.04	2.39	2.76	3.14	3.59	4.00	4.44
90	0.055	0.183	0.361	0.562	0.77	1.05	1.33	1.61	1.94	2.25	2.60	2.97	3.37	3.76	4.20
92	0.048	0.169	0.334	0.521	0.72	0.97	1.23	1.50	1.80	2.10	2.41	2.75	3.10	3.47	3.87
94	0.039	0.155	0.300	0.470	0.65	0.87	1.11	1.36	1.64	1.90	2.20	2.47	2.80	3.10	3.43
95	0.035	0.141	0.276	0.438	0.61	0.82	1.05	1.28	1.55	1.80	2.05	2.31	2.60	2.90	3.19

TABLE 8 Flume, 2.54-cm (1-in.), Submerged—Flowrate, L/s

Submerged, %	H_a , cm																
	2	3	4	5	6	7	8	9	10	11	12	13	14	15	18	21	24
50	0.142	0.263	0.419	0.586	0.767	0.971	1.19	1.44	1.70	1.98	2.27	2.55
55	0.139	0.261	0.416	0.586	0.762	0.960	1.17	1.43	1.67	1.95	2.24	2.52
60	0.136	0.258	0.413	0.578	0.748	0.949	1.16	1.40	1.64	1.90	2.18	2.41
65	0.133	0.249	0.399	0.561	0.725	0.917	1.12	1.37	1.59	1.81	2.10	2.41
70	0.130	0.241	0.382	0.535	0.694	0.878	1.07	1.29	1.50	1.73	1.98	2.27
75	0.125	0.229	0.362	0.510	0.665	0.841	1.02	1.21	1.42	1.64	1.87	2.12	2.38	2.66
80	0.116	0.212	0.337	0.473	0.623	0.779	0.934	1.11	1.33	1.53	1.76	1.95	2.18	2.44
85	0.105	0.190	0.303	0.425	0.555	0.697	0.841	1.00	1.16	1.33	1.36	1.73	1.93	2.12	2.78
90	...	0.160	0.261	0.362	0.467	0.595	0.725	0.858	0.99	1.13	1.27	1.44	1.61	1.78	2.79
95	...	0.133	0.207	0.289	0.374	0.462	0.555	0.665	0.76	0.91	1.02	1.13	1.22	1.39	1.73	2.10	1.49

several types of sensors including, but not restricted to, the following:

- 7.6.2.1 Floats, such as, cylindrical (3) and scow types;
- 7.6.2.2 Pressure sensors, such as, bubble types (3) and (4), diaphragm gages;
- 7.6.2.3 Acoustic sensors;

7.6.2.4 Electrical sensors, such as, resistance, capacitance, and oscillating probes.

8. Sampling

8.1 Sampling as defined in Terminology D 1129 is not applicable in this test method.

TABLE 9 Flume, 5.08-cm (2-in.), Submerged—Flowrate, L/s

Sub-merged, %	H_a , cm																
	2	3	4	5	6	7	8	9	10	11	12	15	18	21	24	27	30
50	0.28	0.52	0.82	1.15	1.53	1.98	2.44	2.86	3.45	4.05	4.59	6.37	8.67
55	0.28	0.52	0.82	1.15	1.52	1.95	2.41	2.86	3.43	4.02	4.53	6.34	8.67	10.62
60	0.27	0.51	0.80	1.14	1.50	1.93	2.38	2.83	3.40	3.96	4.47	6.26	8.61	10.48
65	0.27	0.50	0.79	1.12	1.48	1.90	2.35	2.80	3.34	3.91	4.39	6.17	8.47	10.31
70	0.26	0.48	0.77	1.09	1.44	1.87	2.29	2.72	3.26	3.79	4.28	5.97	8.16	10.02
75	0.25	0.45	0.72	1.03	1.38	1.78	2.18	2.61	3.11	3.62	4.11	5.75	7.79	9.54
80	0.23	0.42	0.67	0.95	1.27	1.67	2.04	2.44	2.89	3.40	3.85	5.35	7.22	9.03	10.96
85	0.20	0.38	0.60	0.85	1.13	1.47	1.84	2.24	2.61	3.03	3.48	4.87	6.48	8.30	9.91
90	...	0.32	0.50	0.71	0.96	1.22	1.50	1.87	2.21	2.58	2.89	4.16	5.55	7.16	8.72	10.22	...
95	...	0.24	0.37	0.52	0.68	0.88	1.08	1.30	1.61	1.90	2.15	3.06	4.13	5.47	6.88	8.30	9.68

TABLE 10 Flume, 7.62-cm (3-in.), Submerged—Flowrate, L/s

Sub-merged, %	H_a , cm																	
	4	6	8	10	12	14	16	18	20	22	24	27	30	33	36	39	42	45
50	1.19	2.27	3.57	5.04	6.65	8.38	10.36	12.46	14.53	16.76	19.31	23.25	27.04	31.7	36.4
55	1.19	2.27	3.57	5.01	6.63	8.35	10.31	12.40	14.47	16.74	19.20	23.11	26.96	31.4	36.3
60	1.19	2.27	3.54	4.98	6.57	8.33	10.25	12.26	14.39	16.62	18.94	22.82	26.73	31.1	35.7
65	1.19	2.27	3.51	4.96	6.54	8.24	10.11	12.06	14.27	16.54	18.80	22.60	26.48	30.9	35.1
70	1.19	2.21	3.45	4.84	6.37	8.10	9.91	11.78	13.93	16.17	18.38	22.12	25.85	30.3	34.5
75	1.16	2.12	3.31	4.67	6.12	7.73	9.51	11.30	13.34	15.49	17.73	21.12	24.86	29.3	32.8	37.1	41.3	...
80	1.10	2.01	3.09	4.42	5.72	7.22	8.95	10.62	12.52	14.55	16.68	19.74	23.22	27.2	30.9	35.1	39.1	...
85	0.99	1.84	2.80	3.96	5.21	6.51	8.10	9.71	11.33	13.08	15.04	18.01	20.98	24.4	27.8	31.4	35.4	...
90	...	1.59	2.46	3.43	4.53	5.61	6.91	8.41	9.80	11.27	12.86	15.52	18.07	20.8	23.6	26.9	30.0	33.4
95	...	1.25	1.90	2.58	3.45	4.33	5.27	6.31	7.45	8.61	9.83	11.69	13.82	15.9	17.9	20.2	22.6	24.9

TABLE 11 Flume, 15.24-cm (6-in.), Submerged—Flowrate, L/s

Sub-merged, %	H_a , cm															
	4	6	9	12	15	18	21	24	27	30	33	36	39	42	45	
60	2.41	4.50	8.30	12.80	18.12	24.1	30.9	38.5	47.0	55.2	64.6	74.2	83.8	93.4	104.2	
62	2.38	4.45	8.21	12.69	18.01	24.0	30.9	38.2	46.4	54.7	64.0	73.3	83.0	92.9	103.4	
64	2.36	4.39	8.04	12.60	17.87	23.8	30.6	37.9	45.9	54.1	63.1	72.8	82.1	92.0	102.5	
66	2.35	4.33	7.93	12.52	17.67	23.6	30.3	37.7	45.3	53.5	62.6	71.9	81.3	91.2	101.4	
68	2.32	4.28	7.87	12.32	17.50	23.5	30.0	37.4	45.0	53.2	62.0	70.8	80.1	90.0	100.5	
70	2.31	4.22	7.82	12.20	17.25	23.2	29.4	36.8	44.2	52.4	60.9	69.9	79.0	88.9	99.4	
72	2.29	4.16	7.70	11.98	17.05	22.9	29.2	36.5	43.6	51.2	59.7	68.8	77.6	87.5	97.7	
74	2.27	4.08	7.59	11.75	16.76	22.6	28.9	36.0	42.8	50.4	58.9	67.4	76.2	85.8	95.7	
76	2.24	3.99	7.48	11.47	16.40	22.2	28.3	34.8	41.9	49.8	57.8	66.0	74.8	84.1	98.7	
78	2.21	3.91	7.28	11.16	16.03	21.6	27.8	34.0	40.8	48.4	56.4	64.3	73.1	82.1	91.7	
80	2.15	3.79	6.97	10.79	15.57	21.1	26.9	33.1	39.9	47.0	54.4	62.3	70.8	79.9	88.9	
82	2.04	3.62	6.71	10.45	14.92	20.5	26.1	32.0	38.8	45.6	52.7	60.3	68.5	77.3	85.8	
84	1.93	3.48	6.48	9.88	14.36	19.6	24.9	30.9	37.1	43.7	50.7	58.5	66.0	74.2	82.7	
86	1.84	3.37	6.20	9.49	13.76	18.6	24.1	29.4	35.7	41.9	48.4	55.8	63.4	70.8	78.7	
88	1.76	3.20	5.83	8.92	13.00	17.6	22.7	28.0	34.0	39.9	46.2	53.0	60.0	67.4	75.0	
90	1.61	2.94	5.41	8.33	12.09	16.4	21.0	26.3	31.7	37.7	42.3	49.8	56.4	63.4	70.5	
92	1.47	2.78	4.84	7.70	11.10	15.0	19.3	24.4	29.4	34.8	40.5	46.2	52.7	59.2	65.7	
94	1.33	2.44	4.30	6.91	9.91	13.4	17.6	22.1	26.9	31.7	37.4	42.5	48.1	53.8	60.0	
95	1.22	2.29	4.02	6.37	9.12	12.5	16.4	20.7	23.8	28.3	33.4	39.6	45.3	51.0	56.9	

9. Calibration

9.1 An in-place calibration of the entire flume system is recommended for highest accuracy. However, calibration of the secondary instrument alone can sometimes be a sufficient procedure provided the flume itself meets all the fabrication and installation requirements of 7.2 and 7.5 and provided further that the basic error associated with such a standard flume (see 11.1) is acceptable for the specific measurement purpose.

9.2 Calibrating the Secondary System:

9.2.1 To check the secondary instrument, it is necessary to make independent reference depth measurements with a scale or preferably a point gage. This measurement is most

accurately made in the stilling well or in an auxiliary well as needed. The zero of the scale or point gage must be carefully referenced to the crest elevation.

9.2.2 The depth indicated by the secondary instrument is compared with the reference depth (9.2.1). If the secondary readout is in terms of flowrate, the indicated flowrate is compared with the flowrate computed from the reference depth, Eq. 1 and Table 1. Repetition of this process over a range of depths will indicate whether zero or span adjustment is needed. Repetition of individual points will provide data on the precision of the system.

9.3 Calibrating the Complete System:

9.3.1 Methods for in-place flume calibration include: