



SLOVENSKI STANDARD
SIST ISO 10434:2000
01-september-2000

Jekleni zasuni s prirobnim zgornjim delom za naftno industrijo in industrijo zemeljskega plina

Bolted bonnet steel gate valves for petroleum and natural gas industries

Robinets-vannes en acier à chapeau boulonné pour les industries du pétrole et du gaz naturel

iTeh STANDARD PREVIEW
(standards.iteh.ai)

Ta slovenski standard je istoveten z: **ISO 10434:1998**

SIST ISO 10434:2000
<https://standards.iteh.ai/catalog/standards/sist/6909a24a-9077-4747-a152-065c6805c4a1/sist-iso-10434-2000>

ICS:

23.060.30	Zapirni ventili (zasuni)	Gate valves
75.180.01	Oprema za industrijo nafte in zemeljskega plina na splošno	Equipment for petroleum and natural gas industries in general

SIST ISO 10434:2000

en

iTeh STANDARD PREVIEW
(standards.iteh.ai)

SIST ISO 10434:2000

<https://standards.iteh.ai/catalog/standards/sist/6909af4a-9077-4747-a152-065c6805c4a1/sist-iso-10434-2000>

INTERNATIONAL
STANDARD

ISO
10434

First edition
1998-10-15

**Bolted bonnet steel gate valves for
petroleum and natural gas industries**

*Robinets-vannes en acier à chapeau boulonné pour les industries du
pétrole et du gaz naturel*

iTeh STANDARD PREVIEW
(standards.iteh.ai)

[SIST ISO 10434:2000](https://standards.iteh.ai/catalog/standards/sist/6909af4a-9077-4747-a152-065c6805c4a1/sist-iso-10434-2000)

[https://standards.iteh.ai/catalog/standards/sist/6909af4a-9077-4747-a152-
065c6805c4a1/sist-iso-10434-2000](https://standards.iteh.ai/catalog/standards/sist/6909af4a-9077-4747-a152-065c6805c4a1/sist-iso-10434-2000)



Reference number
ISO 10434:1998(E)

ISO 10434:1998(E)

Contents

1 Scope	1
2 Normative references	2
3 Definitions	2
4 Pressure/temperature ratings.....	3
5 Design	3
5.1 Body wall thickness.....	3
5.2 Bonnet wall thickness	4
5.3 Body dimensions.....	5
5.3.1 Flanged ends.....	5
5.3.2 Butt-welding ends.....	6
5.3.3 Body seats.....	8
5.3.4 Openings	8
5.4 Bonnet dimensions	8
5.5 Bonnet-to-body joint	9
5.6 Gate	10
5.7 Yoke	11
5.8 Stem and stem nut.....	11
5.9 Packing and packing box.....	13
5.10 Bolting.....	13
5.11 Operation	13
5.12 Auxiliary connections.....	14

iTech STANDARD PREVIEW
(standards.iteh.ai)

[SIST ISO 10434:2000](https://standards.iteh.ai/catalog/standards/sist/6009ef8e-9077-4747-a152-065c6805c4a1/sist-iso-10434-2000)

<https://standards.iteh.ai/catalog/standards/sist/6009ef8e-9077-4747-a152-065c6805c4a1/sist-iso-10434-2000>

© ISO 1998

All rights reserved. Unless otherwise specified, no part of this publication may be reproduced or utilized in any form or by any means, electronic or mechanical, including photocopying and microfilm, without permission in writing from the publisher.

International Organization for Standardization
Case postale 56 • CH-1211 Genève 20 • Switzerland
Internet iso@iso.ch

Printed in Switzerland

6 Materials	17
6.1 Materials other than trim materials	17
6.2 Trim	17
6.3 Repair	20
7 Testing and inspection	20
7.1 Pressure tests	20
7.1.1 Shell test	20
7.1.2 Obturator tightness test	20
7.1.3 Backseat test	21
7.1.4 Optional closure test	21
7.2 Inspection	22
8 Marking	22
8.1 Legibility	22
8.2 Body markings	22
8.3 Ring joint markings	23
8.4 Identification plate	23
9 Preparation for despatch	23
Annex A (informative) Information to be specified by the purchaser	24
Annex B (informative) Identification of valves terms	25
Annex C (informative) Bibliography	26

iTech STANDARD PREVIEW

(standards.iteh.ai)

SIST ISO 10434:2000

<https://standards.iteh.ai/catalog/standards/sist/6909af4a-9077-4747-a152-065c6805c4a1/sist-iso-10434-2000>

Foreword

ISO (the International Organization for Standardization) is a worldwide federation of national standards bodies (ISO member bodies). The work of preparing International Standards is normally carried out through ISO technical committees. Each member body interested in a subject for which a technical committee has been established has the right to be represented on that committee. International organizations, governmental and non-governmental, in liaison with ISO, also take part in the work. ISO collaborates closely with the International Electrotechnical Commission (IEC) on all matters of electrotechnical standardization.

Draft International Standards adopted by the technical committees are circulated to the member bodies for voting. Publication as an International Standard requires approval by at least 75 % of the member bodies casting a vote.

International Standard ISO 10434 was prepared jointly by Technical Committees ISO/TC 153, *Valves*, Subcommittee SC 1, *Design, manufacture, marking and testing*, and ISO/TC 67, *Materials, equipment and offshore structures for petroleum and natural gas industries*, Subcommittee SC 6, *Processing equipment and systems*.

Annexes A, B and C of this International Standard are for information only.

iTeh STANDARD PREVIEW (standards.iteh.ai)

[SIST ISO 10434:2000](https://standards.iteh.ai/catalog/standards/sist/6909af4a-9077-4747-a152-065c6805c4a1/sist-iso-10434-2000)

<https://standards.iteh.ai/catalog/standards/sist/6909af4a-9077-4747-a152-065c6805c4a1/sist-iso-10434-2000>

Introduction

The purpose of this International Standard is to establish, in ISO format, the basic requirements and practices for flanged and butt-welding end steel gate valves of bolted bonnet construction which parallel those given in American Petroleum Institute Standard API 600. In order to maintain compatibility with the flanges defined in ISO 7005-1 and the flanges in the American National Standard ASME B16.5, valves have been designated to be PN-marked for the former and Class-marked for the latter. It is not the purpose of this International Standard to replace ISO 6002 or any other International Standard which is not identified with petroleum refinery or natural gas industry applications.

iTeh STANDARD PREVIEW (standards.iteh.ai)

[SIST ISO 10434:2000](https://standards.iteh.ai/catalog/standards/sist/6909af4a-9077-4747-a152-065c6805c4a1/sist-iso-10434-2000)

<https://standards.iteh.ai/catalog/standards/sist/6909af4a-9077-4747-a152-065c6805c4a1/sist-iso-10434-2000>

iTeh STANDARD PREVIEW
(standards.iteh.ai)

SIST ISO 10434:2000

<https://standards.iteh.ai/catalog/standards/sist/6909af4a-9077-4747-a152-065c6805c4a1/sist-iso-10434-2000>

Bolted bonnet steel gate valves for petroleum and natural gas industries

1 Scope

This International Standard specifies the requirements for a heavy duty series of bolted bonnet steel gate valves for petroleum refinery and related applications where corrosion, erosion and other service conditions indicate a need for full port openings, heavy wall sections and extra large stem diameters.

This specification sets forth the requirements for the following gate valve features:

- bolted bonnet;
- outside screw and yoke;
- rising stems;
- non-rising handwheels;
- single or double gate;
- wedge or parallel seating;
- metallic seating surfaces;
- flanged or butt-welding ends.

iTeh STANDARD PREVIEW
(standards.iteh.ai)

[SIST ISO 10434:2000](https://standards.iteh.ai/catalog/standards/sist/6909af4a-9077-4747-a152-065c6805c4a1/sist-iso-10434-2000)

<https://standards.iteh.ai/catalog/standards/sist/6909af4a-9077-4747-a152-065c6805c4a1/sist-iso-10434-2000>

It covers valves of the nominal sizes DN:

25; 32; 40; 50; 65; 80; 100; 150; 200; 250; 300; 350; 400; 450; 500; 600

and is applicable for nominal pressures PN:

20; 50; 110; 150; 260; 420

when metric sized bolt holes are provided in end flanges and PN designations are marked on the valve body.

It also covers valves of the corresponding nominal pipe sizes NPS:

1; 1 ¼; 1 ½; 2; 2 ½; 3; 4; 6; 8; 10; 12; 14; 16; 18; 20; 24

and applies for equivalent nominal Class ratings:

150; 300; 600; 900; 1 500; 2 500

when inch-sized bolt holes are provided in end flanges and Class designations are marked on the valve body.

It also covers additional marking requirements for valves that are PN (or Class) designated but have flanges drilled for inch (or metric) bolt holes.

2 Normative references

The following standards contain provisions which, through reference in this text, constitute provisions of this International Standard. At the time of the publication, the editions indicated were valid. All standards are subject to revision, and parties to agreements based on this International Standard are encouraged to investigate the possibility of applying the most recent editions of the standards indicated below. Members of IEC and ISO maintain registers of currently valid International Standards.

ISO 7-1:1994, *Pipe threads where pressure-tight joints are made on the threads — Part 1: Dimensions, tolerances and designation.*

ISO 4200:1991, *Plain end steel tubes, welded and seamless — Dimensions.*

ISO 5208:1993, *Industrial valves — Pressure testing of valves.*

ISO 5209:1977, *General purpose industrial valves — Marking.*

ISO 5210:1991, *Industrial valves — Multi-turn valve actuator attachments.*

ISO 5752:—¹⁾, *Metal valves for use in flanged pipe systems — Face-to-face and centre-to-face dimensions.*

ISO 6708:1995, *Pipework components — Definition and selection of DN (nominal size).*

ISO 7005-1:1992, *Metallic flanges — Part 1: Steel flanges.*

ISO 7268:1983, *Pipe components — Definition of nominal pressure.*

ANSI/ASME B1.1:1989, *Unified inch screw threads (UN and UNR thread form).*

ANSI/ASME B1.5:1988 (R1994), *Acme screw threads.*

ANSI/ASME B1.8:1988 (R1994), *Stub Acme screw threads.*

ANSI/ASME B1.12:1987 (R1992), *Screw threads — Class 5 interference — Fit thread.*

ANSI/ASME B1.20.1:1983 (R1992), *Pipe threads, general purpose (inch).*

ANSI/ASME B16.5:1996, *Pipe flanges and flanged fittings.*

ANSI/ASME B16.34:1996, *Valves — Flanged, threaded and welding end.*

ANSI/ASME B18.2.2:1987 (R1993), *Square and hex nuts (inch series).*

ANSI/ASTM A193:1996, *Specification for alloy steel and stainless steel bolting materials for high-temperature service.*

ANSI/ASTM A194:1996, *Specification for carbon and alloy steel nuts for bolts for high-pressure and high-temperature service.*

ANSI/ASTM A307:1994, *Specification for carbon steel bolts and studs, 60 000 psi tensile strength.*

3 Definitions

For the purposes of this International Standard, the definition of nominal size given in ISO 6708 and of nominal pressure given in ISO 7268 apply. Alternatively, the definitions of pressure Class and Nominal Pipe Size given in ANSI/ASME B16.34 apply.

¹⁾ To be published. (Revision of ISO 5752:1982)

4 Pressure/temperature ratings

4.1 The pressure/temperature ratings applicable to the valves specified in this International Standard shall be in accordance with those specified in the tables of ANSI/ASME B16.34 for Standard Class for the applicable material specification and the applicable Class (PN). Restrictions on temperature and pressure conditions, for example those imposed by special soft seals or special trim materials shall be marked on the valve identification plate (see 8.4).

4.2 The temperature for a corresponding pressure rating is the maximum temperature of the pressure-containing shell of the valve. In general, this temperature is the same as that of the contained fluid. The use of a pressure rating corresponding to a temperature other than that of the contained fluid is the responsibility of the user.

4.3 For temperatures below the lowest temperature listed in the pressure/temperature tables (see 4.1), the service pressure shall be no greater than the pressure for the lowest listed temperature. The use of valves at lower temperatures is the responsibility of the user. Consideration should be given to the loss of ductility and impact strength of many materials at low temperature.

5 Design

5.1 Body wall thickness

5.1.1 A valve body schematic is shown in Figure 1. The minimum body wall thickness, t_m , at the time of manufacture shall be as given in table 1, except as indicated in 5.1.2 for butt-welding valve ends. Additional metal thickness needed for assembly stresses, stress concentrations, and shapes other than circular shall be determined by individual manufacturers since these factors vary widely.

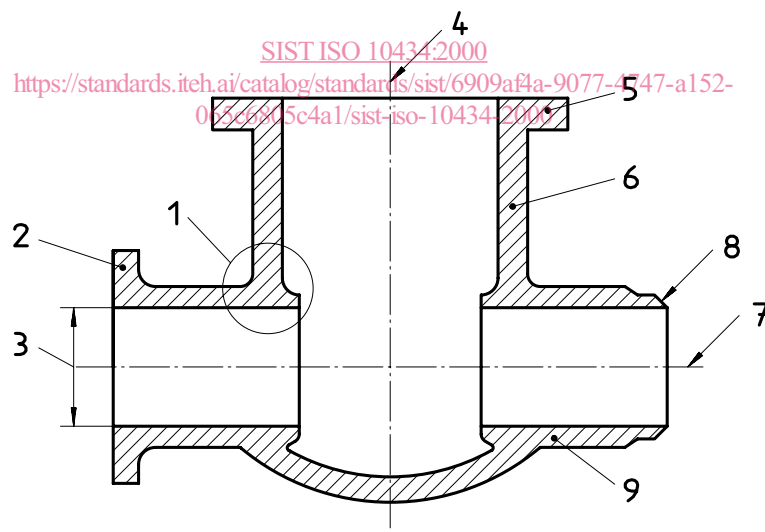

Key

- | | | | |
|---|------------------------------------|---|------------------|
| 1 | Junction of body run and body neck | 6 | Body neck |
| 2 | Body end flange | 7 | Axis of body run |
| 3 | Body end port inside diameter | 8 | Butt-welding end |
| 4 | Axis of body neck | 9 | Body run |
| 5 | Body/bonnet flange | | |

Figure 1 — Identification of terms

5.1.2 The weld end preparation in butt-welding end valves (see 5.3.2) shall not reduce the body wall thickness to less than the values specified in 5.1.1 within a region closer to the outside surface of the body neck than t_m measured along the run direction. The transition to the weld preparation shall be gradual and the section shall be essentially circular through the entire length of the transition. Sharp discontinuities or abrupt changes in section in areas that infringe into the transition shall be avoided, except for test collars or bands, either welded or integral. In no case shall the thickness be less than $0,77 t_m$ at a distance of $1,33 t_m$ from the weld end.

5.2 Bonnet wall thickness

The minimum bonnet wall thickness at the time of manufacture, except for the neck extension which forms the stem and packing entry-way, shall be t_m as given in table 1. For the stem and packing entry-way the local minimum wall thickness shall be based on the local diameter, e.g. the diameter of the stem bore or packing box bore, and shall be in accordance with table 2.

Table 1 — Minimum wall thickness for body and bonnet

Nominal size DN	PN designation						Nominal pipe size NPS
	20	50	110	150	260	420	
	Class designation						
	150	300	600	900	1 500	2 500	
	Minimum wall thickness, t_m mm						
25	6,4	6,4	7,9	12,7	12,7	15	1
32	6,4	6,4	8,6	14,2	14,2	17,5	1¼
40	6,4	7,9	9,4	15	15	19,1	1½
50	8,6	9,7	11,2	19,1	19,1	22,4	2
65	9,7	11,2	11,9	22,4	22,4	25,4	2½
80	10,4	11,9	12,7	19,1	23,9	30,2	3
100	11,2	12,7	16	21,3	28,7	35,8	4
150	11,9	16	19,1	26,2	38,1	48,5	6
200	12,7	17,5	25,4	31,8	47,8	62	8
250	14,2	19,1	28,7	36,6	57,2	67,6	10
300	16	20,6	31,8	42,2	66,8	86,6	12
350	16,8	22,4	35,1	46	69,9	—	14
400	17,5	23,9	38,1	52,3	79,5	—	16
450	18,3	25,4	41,4	57,2	88,9	—	18
500	19,1	26,9	44,5	63,5	98,6	—	20
600	20,6	30,2	50,8	73,2	114,3	—	24