

INTERNATIONAL STANDARD

**ISO
10484**

First edition
1997-11-01

Widening test on nuts

Essai d'évasement des écrous

iTeh STANDARD PREVIEW
(standards.iteh.ai)

ISO 10484:1997

<https://standards.iteh.ai/catalog/standards/sist/ea0f2459-0f13-41fd-97d7-8b61dc6e15ca/iso-10484-1997>



Foreword

ISO (the International Organization for Standardization) is a worldwide federation of national standards bodies (ISO member bodies). The work of preparing International Standards is normally carried out through ISO technical committees. Each member body interested in a subject for which a technical committee has been established has the right to be represented on that committee. International organizations, governmental and non-governmental, in liaison with ISO, also take part in the work. ISO collaborates closely with the International Electrotechnical Commission (IEC) on all matters of electrotechnical standardization.

Draft International Standards adopted by the technical committees are circulated to the member bodies for voting. Publication as an International Standard requires approval by at least 75 % of the member bodies casting a vote.

iTeh STANDARD PREVIEW

International Standard ISO 10484 was prepared by Technical Committee ISO/TC 2, *Fasteners*, Subcommittee SC 1, *Mechanical properties of fasteners*.

[ISO 10484:1997](https://standards.iteh.ai/catalog/standards/sist/ea0f2459-0f13-41fd-97d7-8b61dc6e15ca/iso-10484-1997)

<https://standards.iteh.ai/catalog/standards/sist/ea0f2459-0f13-41fd-97d7-8b61dc6e15ca/iso-10484-1997>

© ISO 1997

All rights reserved. Unless otherwise specified, no part of this publication may be reproduced or utilized in any form or by any means, electronic or mechanical, including photocopying and microfilm, without permission in writing from the publisher.

International Organization for Standardization
Case postale 56 • CH-1211 Genève 20 • Switzerland
Internet central@iso.ch
X.400 c=ch; a=400net; p=iso; o=isocs; s=central

Printed in Switzerland

Widening test on nuts

1 Scope

This International Standard specifies the test procedure for evaluating the acceptability of surface discontinuities designated in ISO 6157-2 excluding nuts made of free cutting steel.

It applies to nuts with

- property classes to ISO 898-2 and ISO 898-6;
- nominal thread diameter, d , from 5 mm up to and including 39 mm;
- product grades A and B.

2 Normative references

The following standards contain provisions which, through reference in this text, constitute provisions of this International Standard. At the time of publication, the editions indicated were valid. All standards are subject to revision, and parties to agreements based on this International Standard are encouraged to investigate the possibility of applying the most recent editions of the standards indicated below. Members of IEC and ISO maintain registers of currently valid International Standards.

ISO 898-2:1992, *Mechanical properties of fasteners – Part 2: Nuts with specified proof load values – Coarse thread.*

ISO 898-6:1994, *Mechanical properties of fasteners – Part 6: Nuts with specified proof load values – Fine pitch thread.*

ISO 2320:1997, *Prevailing torque type steel hexagon nuts – Mechanical and performance properties.*

ISO 6157-2:1995, *Fasteners – Surface discontinuities – Part 2: Nuts.*

3 Widening test

3.1 Principle

After removal of the thread up to the nominal thread diameter a tapered mandrel is pushed into the nut.

The widening is measured as a percentage of the hole diameter.

3.2 Test mandrel

The test mandrel shown in figure 1 shall be used for measurement of widening of 6 % or 4 % respectively (see clause 4). It shall have a minimum hardness of not less than 45 HRC and the cone shall be polished (roughness $R_a = 2,5 \mu\text{m}$).

3.3 Test nut

The nut to be subjected to the widening test shall have the thread removed to a diameter equal to the nominal diameter of the thread with the tolerance H12.

3.4 Procedure

Prior to the test, lubricate the mandrel with molybdenum disulphide (MoS₂).

Insert the mandrel into the nut as shown in figure 2 and apply a load axially in a slow and continuous manner until the mandrel is pushed through the hole up to the cylindrical part. The mandrel shall be tightly clamped at the upper end. For reference purposes the speed of insertion shall not exceed 25 mm/min.

4 Criteria

The total widening of nuts shall be

6 % for nuts of property classes 4 to 12

and

4 % for nuts of property classes 04 and 05.

Failure of a nut occurs when the wall of the nut breaks entirely before the minimum specified widening value is obtained. In cases of doubt, the fracture may be recognized when the nut is cut on the opposite side and then falls into two single parts.

5 Special case – Prevailing torque type nuts

For prevailing torque type nuts according to ISO 2320 the minimum value of widening shall be 20 % below the values for hexagon nuts specified in 4.

iTeh STANDARD PREVIEW
(standards.iteh.ai)
<https://standards.iteh.ai/catalog/standards/sist/ea0f2459-0f13-41fd-97d7-8b61dc6e15ca/iso-10484-1997>

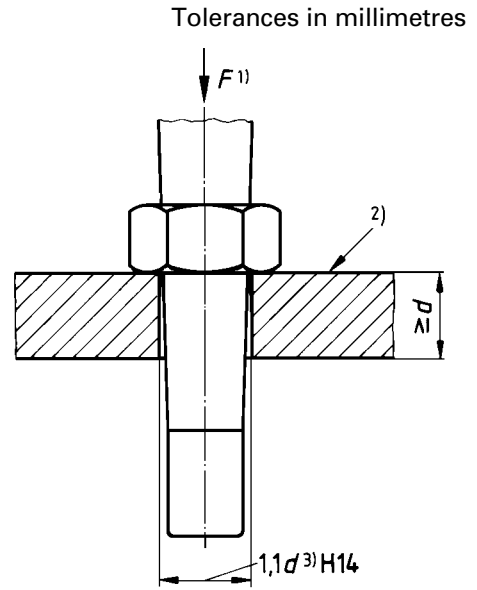
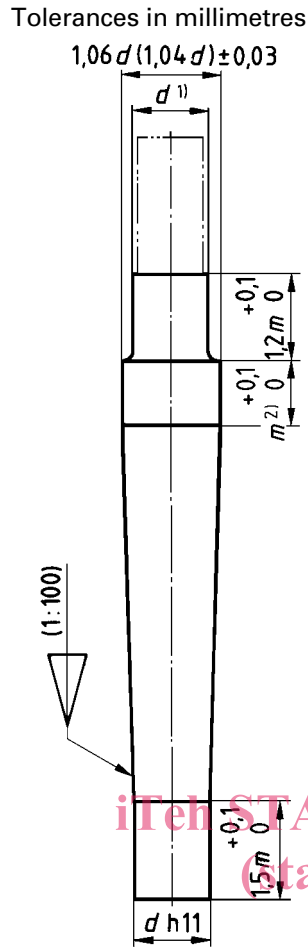

iteh STANDARD PREVIEW
(standards.iteh.ai)

ISO 10484:1997

<https://standards.iteh.ai/catalog/standards/sist/ea0f2459-0f13-41fd-97d7-8b01d38e15ca/iso-10484-1997>

1) d is the nominal thread diameter of the nut. For the testing of oversize tapped nuts the dimension d shall be enlarged according to the major diameter of the internal thread.

1) F is the load.

2) Hardened.

2) m is the nominal height of the nut.

3) d is the nominal thread diameter of the nut.

Figure 1 — Test mandrel for widening of nuts up to 6 % ($1,06 d$) or up to 4 % ($1,04 d$) respectively

Figure 2 — Test assembly

iTeh STANDARD PREVIEW
(standards.iteh.ai)

ISO 10484:1997

<https://standards.iteh.ai/catalog/standards/sist/ea0f2459-0f13-41fd-97d7-8b61dc6e15ca/iso-10484-1997>

ICS 21.060.20

Descriptors: fasteners, nuts (fasteners), tests, mechanical tests, estimation, surface defects.

Price based on 3 pages
