

# INTERNATIONAL STANDARD

# NORME INTERNATIONALE

Hand-held motor-operated electric tools – Safety –  
Part 2-14: Particular requirements for planers

[standards.iteh.ai](http://standards.iteh.ai)

Outils électroportatifs à moteur – Sécurité –  
Partie 2-14: Règles particulières pour les rabots

<https://standards.iteh.ai/catalog/standards/sist/6060182-5e1f-4b91-bc36-458672c1fa83/iec-60745-2-14-2003amd1-2006amd2-2010-csv>



## THIS PUBLICATION IS COPYRIGHT PROTECTED

Copyright © 2010 IEC, Geneva, Switzerland

All rights reserved. Unless otherwise specified, no part of this publication may be reproduced or utilized in any form or by any means, electronic or mechanical, including photocopying and microfilm, without permission in writing from either IEC or IEC's member National Committee in the country of the requester.

If you have any questions about IEC copyright or have an enquiry about obtaining additional rights to this publication, please contact the address below or your local IEC member National Committee for further information.

Droits de reproduction réservés. Sauf indication contraire, aucune partie de cette publication ne peut être reproduite ni utilisée sous quelque forme que ce soit et par aucun procédé, électronique ou mécanique, y compris la photocopie et les microfilms, sans l'accord écrit de la CEI ou du Comité national de la CEI du pays du demandeur.

Si vous avez des questions sur le copyright de la CEI ou si vous désirez obtenir des droits supplémentaires sur cette publication, utilisez les coordonnées ci-après ou contactez le Comité national de la CEI de votre pays de résidence.

IEC Central Office  
3, rue de Varembe  
CH-1211 Geneva 20  
Switzerland  
Email: [inmail@iec.ch](mailto:inmail@iec.ch)  
Web: [www.iec.ch](http://www.iec.ch)

### About the IEC

The International Electrotechnical Commission (IEC) is the leading global organization that prepares and publishes International Standards for all electrical, electronic and related technologies.

### About IEC publications

The technical content of IEC publications is kept under constant review by the IEC. Please make sure that you have the latest edition, a corrigenda or an amendment might have been published.

- Catalogue of IEC publications: [www.iec.ch/searchpub](http://www.iec.ch/searchpub)

The IEC on-line Catalogue enables you to search by a variety of criteria (reference number, text, technical committee,...). It also gives information on projects, withdrawn and replaced publications.

- IEC Just Published: [www.iec.ch/online\\_news/justpub](http://www.iec.ch/online_news/justpub)

Stay up to date on all new IEC publications. Just Published details twice a month all new publications released. Available on-line and also by email.

- Electropedia: [www.electropedia.org](http://www.electropedia.org)

The world's leading online dictionary of electronic and electrical terms containing more than 20 000 terms and definitions in English and French, with equivalent terms in additional languages. Also known as the International Electrotechnical Vocabulary online.

- Customer Service Centre: [www.iec.ch/webstore/custserv](http://www.iec.ch/webstore/custserv)

If you wish to give us your feedback on this publication or need further assistance, please visit the Customer Service Centre FAQ or contact us:

Email: [csc@iec.ch](mailto:csc@iec.ch)  
Tel.: +41 22 919 02 11  
Fax: +41 22 919 03 00

### A propos de la CEI

La Commission Electrotechnique Internationale (CEI) est la première organisation mondiale qui élabore et publie des normes internationales pour tout ce qui a trait à l'électricité, à l'électronique et aux technologies apparentées.

### A propos des publications CEI

Le contenu technique des publications de la CEI est constamment revu. Veuillez vous assurer que vous possédez l'édition la plus récente, un corrigendum ou amendement peut avoir été publié.

- Catalogue des publications de la CEI: [www.iec.ch/searchpub/cur\\_fut-f.htm](http://www.iec.ch/searchpub/cur_fut-f.htm)

Le Catalogue en-ligne de la CEI vous permet d'effectuer des recherches en utilisant différents critères (numéro de référence, texte, comité d'études,...). Il donne aussi des informations sur les projets et les publications retirées ou remplacées.

- Just Published CEI: [www.iec.ch/online\\_news/justpub](http://www.iec.ch/online_news/justpub)

Restez informé sur les nouvelles publications de la CEI. Just Published détaille deux fois par mois les nouvelles publications parues. Disponible en-ligne et aussi par email.

- Electropedia: [www.electropedia.org](http://www.electropedia.org)

Le premier dictionnaire en ligne au monde de termes électroniques et électriques. Il contient plus de 20 000 termes et définitions en anglais et en français, ainsi que les termes équivalents dans les langues additionnelles. Egalement appelé Vocabulaire Electrotechnique International en ligne.

- Service Clients: [www.iec.ch/webstore/custserv/custserv\\_entry-f.htm](http://www.iec.ch/webstore/custserv/custserv_entry-f.htm)

Si vous désirez nous donner des commentaires sur cette publication ou si vous avez des questions, visitez le FAQ du Service clients ou contactez-nous:

Email: [csc@iec.ch](mailto:csc@iec.ch)  
Tél.: +41 22 919 02 11  
Fax: +41 22 919 03 00



IEC 60745-2-14

Edition 2.2 2010-09

# INTERNATIONAL STANDARD

## NORME INTERNATIONALE

---

**Hand-held motor-operated electric tools – Safety –  
Part 2-14: Particular requirements for planers**

**Outils électroportatifs à moteur – Sécurité –  
Partie 2-14: Règles particulières pour les rabots**

INTERNATIONAL  
ELECTROTECHNICAL  
COMMISSION

COMMISSION  
ELECTROTECHNIQUE  
INTERNATIONALE

---

ICS 25.140.20

ISBN 978-2-88912-124-3

## CONTENTS

FOREWORD .....	3
1 Scope .....	5
2 Normative references .....	5
3 Terms and definitions .....	5
4 General requirements .....	5
5 General conditions for the tests .....	5
6 Void .....	5
7 Classification .....	6
8 Marking and instructions .....	6
9 Protection against access to live parts .....	6
10 Starting .....	6
11 Input and current .....	6
12 Heating .....	6
13 Leakage current .....	7
14 Moisture resistance .....	7
15 Electric strength .....	7
16 Overload protection of transformers and associated circuits .....	7
17 Endurance .....	7
18 Abnormal operation .....	7
19 Mechanical hazards .....	7
20 Mechanical strength .....	13
21 Construction .....	13
22 Internal wiring .....	13
23 Components .....	13
24 Supply connection and external flexible cords .....	13
25 Terminals for external conductors .....	13
26 Provision for earthing .....	13
27 Screws and connections .....	13
28 Creepage distances, clearances and distances through insulation .....	14
29 Resistance to heat, fire and tracking .....	14
30 Resistance to rusting .....	14
31 Radiation, toxicity and similar hazards .....	14
Annexes .....	15
Annex K (normative) Battery tools and battery packs .....	15
Annex L (normative) Battery tools and battery packs provided with mains connection or non-isolated sources .....	15
Bibliography .....	15
Figure 101 – Examples of cutting heads with basic dimensions and clearance distances .....	10
Figure 102 – Test probe .....	11
Figure 103 – Examples of parallel guide and guard .....	12

## INTERNATIONAL ELECTROTECHNICAL COMMISSION

### HAND-HELD MOTOR-OPERATED ELECTRIC TOOLS – SAFETY –

#### Part 2-14: Particular requirements for planers

#### FOREWORD

- 1) The International Electrotechnical Commission (IEC) is a worldwide organization for standardization comprising all national electrotechnical committees (IEC National Committees). The object of IEC is to promote international co-operation on all questions concerning standardization in the electrical and electronic fields. To this end and in addition to other activities, IEC publishes International Standards, Technical Specifications, Technical Reports, Publicly Available Specifications (PAS) and Guides (hereafter referred to as “IEC Publication(s)”). Their preparation is entrusted to technical committees; any IEC National Committee interested in the subject dealt with may participate in this preparatory work. International, governmental and non-governmental organizations liaising with the IEC also participate in this preparation. IEC collaborates closely with the International Organization for Standardization (ISO) in accordance with conditions determined by agreement between the two organizations.
- 2) The formal decisions or agreements of IEC on technical matters express, as nearly as possible, an international consensus of opinion on the relevant subjects since each technical committee has representation from all interested IEC National Committees.
- 3) IEC Publications have the form of recommendations for international use and are accepted by IEC National Committees in that sense. While all reasonable efforts are made to ensure that the technical content of IEC Publications is accurate, IEC cannot be held responsible for the way in which they are used or for any misinterpretation by any end user.
- 4) In order to promote international uniformity, IEC National Committees undertake to apply IEC Publications transparently to the maximum extent possible in their national and regional publications. Any divergence between any IEC Publication and the corresponding national or regional publication shall be clearly indicated in the latter.
- 5) IEC itself does not provide any attestation of conformity. Independent certification bodies provide conformity assessment services and, in some areas, access to IEC marks of conformity. IEC is not responsible for any services carried out by independent certification bodies.
- 6) All users should ensure that they have the latest edition of this publication.
- 7) No liability shall attach to IEC or its directors, employees, servants or agents including individual experts and members of its technical committees and IEC National Committees for any personal injury, property damage or other damage of any nature whatsoever, whether direct or indirect, or for costs (including legal fees) and expenses arising out of the publication, use of, or reliance upon, this IEC Publication or any other IEC Publications.
- 8) Attention is drawn to the Normative references cited in this publication. Use of the referenced publications is indispensable for the correct application of this publication.
- 9) Attention is drawn to the possibility that some of the elements of this IEC Publication may be the subject of patent rights. IEC shall not be held responsible for identifying any or all such patent rights.

This part of International Standard IEC 60745 has been prepared by subcommittee 61F: Safety of hand-held motor-operated electric tools, of IEC technical committee 61: Safety of household and similar electrical appliances

This consolidated version of IEC 60745-2-14 consists of the second edition (2003) [documents 61F/467/FDIS and 61F/491/RVD], its amendment 1 (2006) [documents 61F/633/FDIS and 61F/642/RVD] and its amendment 2 (2010) [documents 116/35/FDIS and 116/43/RVD].

The technical content is therefore identical to the base edition and its amendments and has been prepared for user convenience.

It bears the edition number 2.2.

A vertical line in the margin shows where the base publication has been modified by amendments 1 and 2.

The French version of this standard has not been voted upon.

This publication has been drafted in accordance with the ISO/IEC Directives, Part 2.

This part 2 is to be used in conjunction with the latest edition of IEC 60745-1, *Hand-held motor-operated electric tools – Safety – Part 1: General requirements*, and its amendments. It was established on the basis of the third edition (2001) of that standard.

NOTE 1 When “Part 1” is mentioned in this standard, it refers to IEC 60745-1.

This part 2 supplements or modifies the corresponding clauses of IEC 60745-1, so as to convert that publication into the IEC standard: Safety requirements for electric planers.

When a particular subclause of Part 1 is not mentioned in this part 2, that subclause applies as far as is reasonable. When this standard states “addition”, “modification” or “replacement”, the relevant text in Part 1 is to be adapted accordingly.

NOTE 2 The following numbering system is used:

- subclauses, tables and figures that are numbered starting from 101 are additional to those in Part 1;
- additional annexes are lettered AA, BB, etc.

NOTE 3 In this standard, the following print types are used:

- requirements: in roman type;
- *test specifications: in italic type;*
- notes: in smaller roman type.

Words in **bold** in the text are defined in Clause 3. When a definition concerns an adjective, the adjective and the associated noun are also in bold.

The committee has decided that the contents of the base publication and its amendments will remain unchanged until the stability date indicated on the IEC web site under "<http://webstore.iec.ch>" in the data related to the specific publication. At this date, the publication will be

- reconfirmed,
- withdrawn,
- replaced by a revised edition, or
- amended.

## HAND-HELD MOTOR-OPERATED ELECTRIC TOOLS – SAFETY –

### Part 2-14: Particular requirements for planers

#### 1 Scope

This clause of Part 1 is applicable except as follows:

*Addition:*

This standard applies to planers.

#### 2 Normative references

This clause of Part 1 is applicable.

#### 3 Terms and definitions

This clause of Part 1 is applicable except as follows:

##### 3.101 planer

IEC 60745-2-14:2003+AMD1:2006+AMD2:2010 CSV  
<https://standards.iteh.ai/catalog/standards/sist/60d60182-5e1f-4b91-bc36-45892e148316/iec-60745-2-14-2003amd1-2006amd2-2010-csv>  
tool intended for removing surface material, equipped with a rotating cutting head where the axis of the cutting head is parallel to the base plate

##### 3.102 lift-off device

device which keeps the blade(s) from making contact when the planer is placed on a flat surface

##### 3.103 cutting head

assembly of blades, cutter block, blade fixing elements, relevant screws and spindle, the whole being ready for working

#### 4 General requirements

This clause of Part 1 is applicable.

#### 5 General conditions for the tests

This clause of Part 1 is applicable.

#### 6 Void

## 7 Classification

This clause of Part 1 is applicable.

## 8 Marking and instructions

This clause of Part 1 is applicable, except as follows:

### 8.1 Addition:

- direction of rotation of the working spindle. This shall be indicated by an arrow, raised or sunk, or by other means no less visible and indelible;
- rated no load speed.

### 8.12.1.1 Addition

#### Planer safety warnings

- **Wait for the cutter to stop before setting the tool down.** *An exposed rotating cutter may engage the surface leading to possible loss of control and serious injury.*

NOTE The above warning applies only to planers without an automatic closing guard.

- **Hold the power tool by insulated gripping surfaces only, because the cutter may contact its own cord.** *Cutting a "live" wire may make exposed metal parts of the power tool "live" and could give the operator an electric shock.*

- **Use clamps or another practical way to secure and support the workpiece to a stable platform.** *Holding the work by your hand or against the body leaves it unstable and may lead to loss of control.*

### 8.12.2 Addition:

<https://standards.iteh.ai/catalog/standards/sist/60d60182-5e1f-4b91-bc36-458672c1fa83/iec-60745-2-14-2003amd1-2006amd2-2010-csv>

The instruction sheet shall also contain the following information:

- instructions for the changing of the blades and their adjustment to the correct position;
- types of cutting heads which can be used, if applicable.

## 9 Protection against access to live parts

This clause of Part 1 is applicable.

## 10 Starting

This clause of Part 1 is applicable.

## 11 Input and current

This clause of Part 1 is applicable.

## 12 Heating

This clause of Part 1 is applicable, except as follows:



#### 12.4 Replacement:

*The tool is operated at rated input or rated current for 30 min. The temperature rises are measured at the end of the 30 min.*

### 13 Leakage current

This clause of Part 1 is applicable.

### 14 Moisture resistance

This clause of Part 1 is applicable.

### 15 Electric strength

This clause of Part 1 is applicable.

### 16 Overload protection of transformers and associated circuits

This clause of Part 1 is applicable.

### 17 Endurance

This clause of Part 1 is applicable.

### 18 Abnormal operation

This clause of Part 1 is applicable.

### 19 Mechanical hazards

This clause of Part 1 is applicable except as follows:

#### 19.1 Addition:

*For the requirements given in 19.106, 19.107 and 19.108, only the test probe shown in Figure 102 is used.*

**19.101** The blades when aligned with the fixed shoe shall not project by more than 1,1 mm radially beyond the cutter block (as per dimension “a” in Figure 101).

*Compliance is checked by measurement.*

**19.102** At any depth of cut, the distance “b” (see Figure 101) between the rotating circle of the cutting edges and the trailing edge on the side of the adjustable shoe shall not exceed 5 mm measured radially.

*Compliance is checked by measurement and by inspection.*

iTeh STANDARD PREVIEW  
(standards.iteh.ai)

<https://standards.iteh.ai/catalog/standards/sist/60d60182-5e1f-4b91-bc36-456072c1fa83/iec-60745-2-14-2003amd1-2006amd2-2010-csv>

<https://standards.iteh.ai/catalog/standards/sist/60d60182-5e1f-4b91-bc36-456072c1fa83/iec-60745-2-14-2003amd1-2006amd2-2010-csv>

**19.103** The blades shall be secured in the cutter block in such a way that friction alone is not relied upon to prevent the ejection of the blades.

*Compliance is checked by measurement and by inspection.*

**19.104** Cutting heads shall be designed and made of such materials that they withstand the forces and loads expected in normal use.

*Compliance is checked by the following test:*

*An overspeed test shall be made on a sample cutting head, equipped with blades for the largest cutting diameter and the largest cutting edge width, the test speed being 1,5 times the rated no-load speed. If applicable, tension elements such as clamping screws shall be tightened in accordance with the instructions required by 8.12.2.*

*After the test, the cutting head shall not be deformed or cracked, no screws shall be loosened and displacements of detachable parts shall be less than specified in the test procedure.*

*The test procedure is as follows:*

- 1) Measure the cutting head dimensions.
- 2) Bring the cutting head to the rated no-load speed, for 1 min.
- 3) Stop and re-measure the cutting head; measured displacements of the detachable parts of the cutting head shall not be greater than 0,15 mm.
- 4) Bring the cutting head to the test speed, for 1 min.
- 5) Stop and re-measure the cutting head and compare the results with those obtained from step 3. The compared displacements shall not exceed 0,15 mm.

**19.105** The clamping screws or other tensile loaded blade fixing elements used to secure the blades in the cutter block shall be made of steel with a hardness of at least 20 HRC and a tensile strength of at least 800 N/mm<sup>2</sup>.

Clamping screws or bolts shall not project beyond the cutter block as shown in Figure 101.

*Compliance is checked by verification of the material specification and by inspection.*

**19.106** It shall not be possible to touch rotating parts from the sides of the planer.

*Compliance is checked by the following test:*

*The planer is positioned with the shoes resting on a flat surface. The accessibility of rotating parts is checked by means of the test probe shown in Figure 102.*

**19.107** Planers with rabbeting facilities shall be provided with a guard that avoids inadvertent contact at the sides with the blades.

*Compliance is checked by inspection and by applying the test probe of Figure 102 without any force with the planer in the same position as required in 19.106.*

**19.108** It shall not be possible to touch the blades through the chip ejection opening.

*Compliance is checked by testing all apertures for chip ejection with the test probe of Figure 102. It shall not be possible to touch the blades in the cutting head at any angle of the probe.*

**19.109** If a parallel guide is provided, its guiding and top surface shall have no openings or projections. Openings having a maximum dimension not exceeding 10 mm are disregarded.

Planers may be provided with an integrated non-detachable and non-lockable guard which automatically moves to the closed position, where it covers the whole width of the cutting head, when the planer is not in use.

The guard provided shall return automatically to the closed position at the end of the planing operation. The parallel guide and guard shall be so designed that for any cutting width the unused part of the cutting head is covered.

Any contact between guards manufactured from steel and other hard materials and the blades is to be avoided. If either the guard or parallel guide is designed in such a way that elimination of contact with the cutting head cannot be ensured, they shall be manufactured from soft material (e.g. aluminium, plastic, wood).

*Compliance is checked by inspection.*

NOTE Examples of parallel guide and guard are given in Figure 103.

**19.110** Planers shall stop within 10 s of switching off, unless the tool is fitted with an automatic closing guard.

*Compliance is checked by inspection and by measurement.*

**19.111** If a lift-off device is provided, it shall be designed so that

- it is automatically activated, when the planer is lifted up from a horizontal surface, and
- the blade(s) do not make contact, when the planer is set at maximum depth of cut and placed on a horizontal surface.

*Compliance is checked by inspection.*

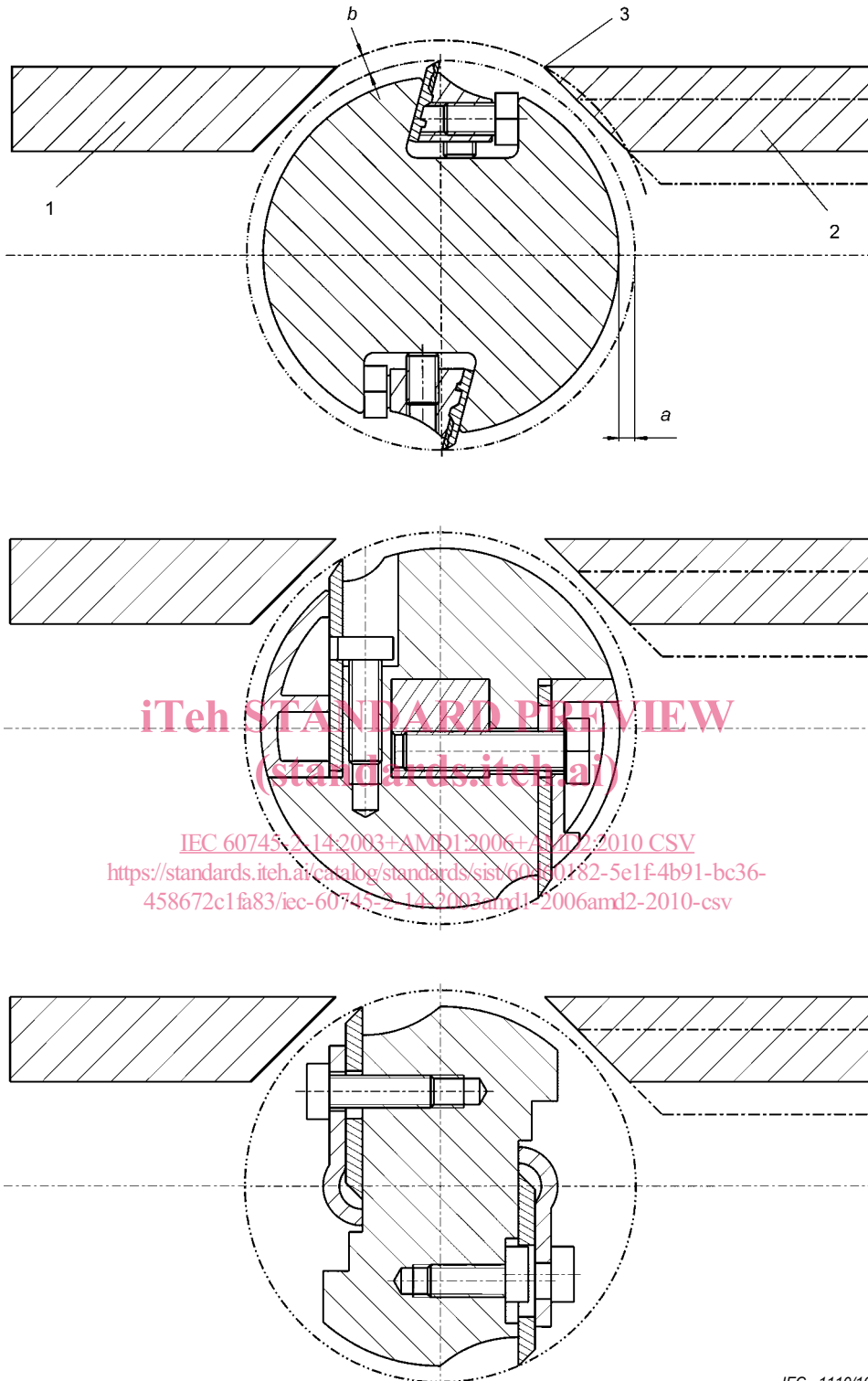

IEC 60745-2-14:2003+AMD1:2006+AMD2:2010 CSV  
<https://standards.iteh.ai/catalog/standards/sist/60745-2-14-2003+amd1-2006amd2-2010-csv>

**Key**

- 1 Fixed shoe
- 2 Adjustable shoe
- 3 Trailing edge

IEC 1110/10

**Figure 101 – Examples of cutting heads with basic dimensions and clearance distances**