INTERNATIONAL STANDARD



1926

INTERNATIONAL ORGANIZATION FOR STANDARDIZATION • МЕЖДУНАРОДНАЯ ОРГАНИЗАЦИЯ ПО СТАНДАРТИЗАЦИИ • ORGANISATION INTERNATIONALE DE NORMALISATION

Rigid cellular plastics — Determination of tensile properties

First edition — 1972-06-01

FOREWORD

ISO (the International Organization for Standardization) is a worldwide federation of national standards institutes (ISO Member Bodies). The work of developing International Standards is carried out through ISO Technical Committees. Every Member Body interested in a subject for which a Technical Committee has been set up has the right to be represented on that Committee. International organizations, governmental and non-governmental, in liaison with ISO, also take part in the work.

Draft International Standards adopted by the Technical Committees are circulated to the Member Bodies for approval before their acceptance as International Standards by the ISO Council.

International Standard ISO 1926 was drawn up by Technical Committee ISO/TC 61, *Plastics*.

It was approved in May 1970 by the Member Bodies of the following countries:

Austria	Hungary	Romania
Belgium	India	South Africa, Rep. of
Canada	Italy	Sweden
Czechoslovakia	Japan	Switzerland
Egypt, Arab Rep. of	Netherlands	Turkey
France	New Zealand	U.S.A.
Germany	Poland	U.S.S.R.
Greece	Portugal	Yugoslavia

The Member Body of the following country expressed disapproval of the document on technical grounds:

United Kingdom

Rigid cellular plastics — Determination of tensile properties

1 SCOPE AND FIELD OF APPLICATION

This International Standard specifies a method of determining the behaviour of rigid cellular plastics products when they are subjected to a tensile stress.

This International Standard applies in the first place to cellular products having a compression resistance sufficient to permit suitable gripping of the test pieces. In case it is impossible to grip the test piece, modify the method according to the specifications in section 8.

The relationship between cell size and test piece size must be such that the test is realistic.

2 REFERENCE

ISO/R 291, *Standard atmospheres for conditioning and testing*.

3 PRINCIPLE

Submission of a test piece of a given shape to a tensile stress transmitted to the test piece by means of a suitable device and plotting of the corresponding stress-strain curve.

4 APPARATUS

The test machine shall be such that

a) the test piece can be held in the fixing devices of the test apparatus. These devices shall meet the following conditions:

- 1) that of assuring a sufficient tightening on the faces of the test piece to avoid slipping;
- 2) that of not exercising on any one part of the ends of the test piece localized pressure which could cause tears, deformations or ruptures of the ends.

In cases of difficulty, adopt the variation described in section 8.

b) the movable device can be moved away from the fixed device at a constant speed under no load of 5 ± 1 mm/min in a direction parallel to the longitudinal axis of the test piece;

c) the force thus exerted on the test piece can be known with a maximum error of 1%, and can be recorded;

d) if an extensometer is used it exerts a minimum force on the test piece and permits reading of elongation of the test piece with an accuracy of 0.1 mm.

5 TEST PIECES

5.1 Dimensions

The test pieces shall have the shape and the dimensions shown in Figure 1.

The distance between two parallel surfaces of the extensometer gauge length shall not vary by more than 1% (tolerance on parallelism).

5.2 Preparation and conditioning

Any moulding skin shall be removed from the test pieces; their surfaces shall be trimmed with a mechanical saw and, if necessary, machined without modifying the structure.

When necessary the test pieces shall be marked so as to indicate their orientation in relation to the direction of anisotropy.

The conditioning of the test pieces shall be carried out in accordance with the requirements of either ISO/R 291 for a period of not less than 24 h or the relevant material specification.

5.3 Number of test pieces

The test shall be carried out on at least five test pieces; any test pieces which break outside the extensometer gauge length shall be rejected and if necessary the number of test pieces subjected to the test shall be increased so that the number of significant results is not less than five.

If it is necessary to use more than seven test pieces to obtain five valid readings, use the method described in section 8.

6 PROCEDURE

Carry out the test in a room in which the atmosphere is maintained at one of the conditions defined by ISO/R 291.

Place the test piece between the fixing devices. If necessary, proceed according to section 8. Mark the original gauge length on the test piece.

Apply the force to be exerted on the test piece in such a way that it is uniformly distributed by means of the movable grip, the rate of displacement of which shall be 5 ± 1 mm/min.

If an extensometer is not used, record the elongation corresponding to a given force, at suitable intervals.

Plot the stress-strain curve.

7 CALCULATION AND EXPRESSION OF RESULTS

7.1 Relative elongation

The relative elongation, e , expressed as a percentage of the original gauge length, is given by the formula

$$e = \frac{\Delta L}{L} \times 100$$

where

ΔL is the elongation corresponding to a given force, measured by the variation in distance between the gauge marks, expressed in millimetres;

L is the original gauge length of the test piece, expressed in millimetres.

Calculate in particular (after determination, on the stress-strain curve, of the corresponding elongations)

- the relative elongation e_m for the maximum stress (if necessary);
- the relative elongation e_r at rupture.

7.2 Maximum tensile stress

The maximum tensile stress, σ_m (where applicable), expressed in kilonewtons per square metre, is given by the formula

$$\sigma_m = \frac{F_m}{l \times h} \times 10^3$$

where

F_m is the maximum force applied to the test piece during the test, expressed in newtons;

l is the original width of the parallel length of the narrow section of the test piece, expressed in millimetres;

h is the original thickness of the parallel length of the narrow section of the test piece, expressed in millimetres.

7.3 Tensile stress at rupture

The tensile stress at rupture, σ_r , expressed in kilonewtons per square metre, is given by the formula

$$\sigma_r = \frac{F_r}{l \times h} \times 10^3$$

where

F_r is the force applied to the test piece at the moment of rupture, expressed in newtons;

l and h have the same meaning as in 7.2.

8 VARIATION: USE OF METAL PLATES

This variation differs from the general method in that the ends of the test pieces are modified to allow the bonding of reinforcing metal plates.

Consequently, follow the directions of sections 4 to 7 taking into account the following modifications:

8.1 Apparatus

8.1.1 Test machine

The test machine shall be such that

- a) a test piece having the form and dimensions shown in Figure 2 can be held between two fixing devices each comprising two cylinders of a diameter of 30 mm orthogonal to the plane of the test piece, one of the devices being fixed and the other movable, the force being transmitted equally by each of the four cylinders;

b), c), d), see section 4.

8.1.2 *Metal plates* of the form and dimensions shown in Figure 2; four are required for each test piece subjected to the test. (Plates of aluminium alloy or anodized aluminium are likely to be satisfactory.)

8.1.3 *Adhesive* for fixing the metal plates to the test pieces. It shall be such that the shear strength of the adhesive film is greater than that of the cellular product under test, so as to avoid any slipping of the test piece on the plates. Preliminary tests shall make it possible to verify that the elongation of this film can be disregarded in the determination of the elongation of the test piece. In addition, the adhesive film shall not appreciably modify the characteristics of the cellular product. (An epoxy resin base adhesive is likely to be satisfactory.)

8.2 Test pieces

8.2.1 Dimensions

The test pieces shall have the shape and the dimensions shown in Figure 2.

The distance between two parallel surfaces of the extensometer gauge length shall not vary by more than 1 % (tolerance on parallelism).

8.2.2 Preparation and conditioning

Four metal plates exactly covering the ends of each test piece shall be glued to these ends, as shown in Figure 2, in order to reinforce them.

A bonding jig which will maintain the metal plates strongly in place face to face shall be used at the time of bonding and during the setting time.

For conditioning of the test pieces, see 5.2.

8.2.3 Number of test pieces: see 5.3.

8.3 Procedure

Because metal plates are used, the elongation of the test piece may be measured by the separation of the machine grips.

8.4 Calculation and expression of results

See section 7.

9 TEST REPORT

The test report shall include the following particulars :

- a) the nature of the product;
- b) the conditioning procedure;
- c) which of the two types of test pieces has been used; if the variation described in section 8 is used, state clearly: "metal plates used";
- d) the number of test pieces used;
- e) where applicable, the direction of the tensile force in relation to the direction of anisotropy;
- f) the individual results calculated using the formulae given in section 7, and their average;
- g) the stress-strain curve;
- h) the date of the test;
- i) any operational details not specified in this International Standard, together with all incidents likely to have affected the results.

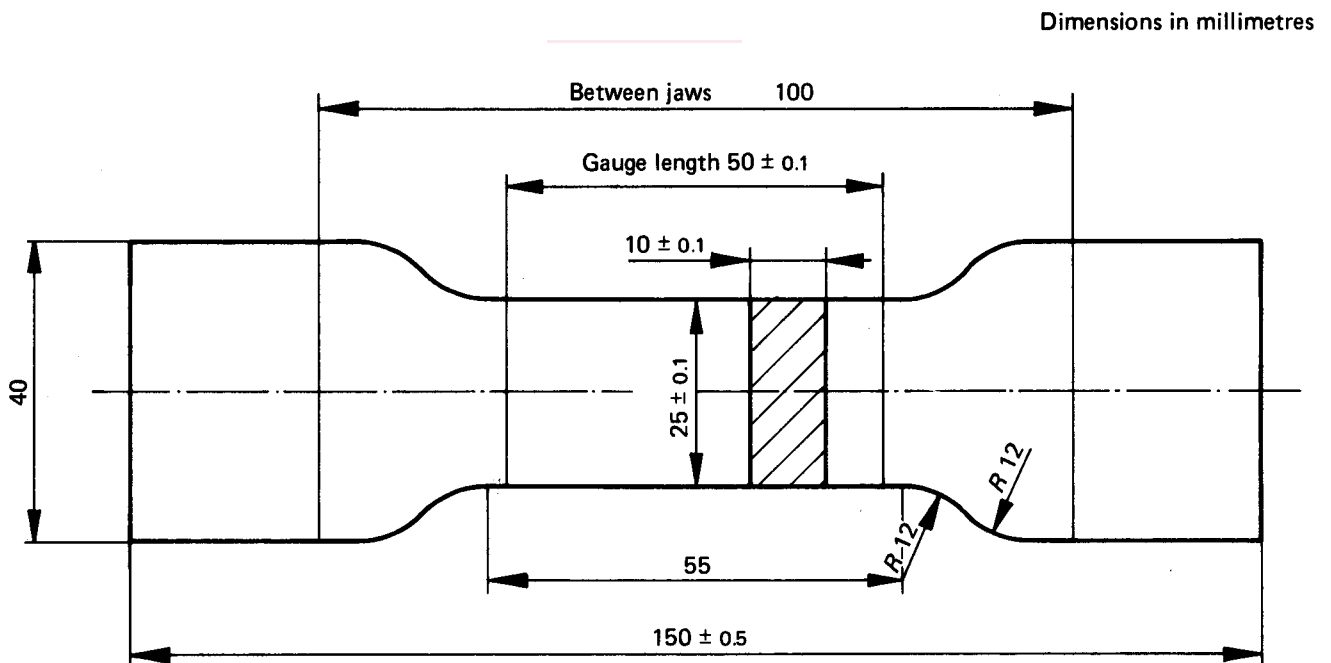

FIGURE 1 — Tensile test piece