



SLOVENSKI STANDARD
SIST ISO 10578:1995

01-junij-1995

HM b] bYf]gVY!Hc`Yf]Ub`Ycf]YbHUV`Y]b`Y[Y!`Dfc`Vf]Ubc`lc`YfUb bc`cVa c`Y

Technical drawings -- Tolerancing of orientation and location -- Projected tolerance zone

Dessins techniques -- Tolérancement d'orientation et de position -- Zone de tolérance projetée

(standards.iteh.ai)

Ta slovenski standard je istoveten z: ISO 10578:1992

<https://standards.iteh.ai/catalog/standards/sist/235f561d-d65f-4fdb-81c8-d6552825c793/sist-iso-10578-1995>

ICS:

01.100.20	Konstruktivske risbe	Mechanical engineering drawings
-----------	----------------------	---------------------------------

SIST ISO 10578:1995

en

iTeh STANDARD PREVIEW
(standards.iteh.ai)

[SIST ISO 10578:1995](#)

<https://standards.iteh.ai/catalog/standards/sist/235f561d-d65f-4fdb-81c8-d6552825c793/sist-iso-10578-1995>

INTERNATIONAL STANDARD

ISO
10578

First edition
1992-07-15

Technical drawings — Tolerancing of orientation and location — Projected tolerance zone

iTeh STANDARD PREVIEW
*Dessins techniques — Tolérancement d'orientation et de position —
Zone de tolérance projetée*
(standards.iteh.ai)

SIST ISO 10578:1995

<https://standards.iteh.ai/catalog/standards/sist/235f561d-d65f-4fdb-81c8-d6552825c793/sist-iso-10578-1995>



Reference number
ISO 10578:1992(E)

Foreword

ISO (the International Organization for Standardization) is a worldwide federation of national standards bodies (ISO member bodies). The work of preparing International Standards is normally carried out through ISO technical committees. Each member body interested in a subject for which a technical committee has been established has the right to be represented on that committee. International organizations, governmental and non-governmental, in liaison with ISO, also take part in the work. ISO collaborates closely with the International Electrotechnical Commission (IEC) on all matters of electrotechnical standardization.

Draft International Standards adopted by the technical committees are circulated to the member bodies for voting. Publication as an International Standard requires approval by at least 75 % of the member bodies casting a vote.

International Standard ISO 10578 was prepared by Technical Committee ISO/TC 10, *Technical drawings, product definition and related documentation*, Sub-Committee SC 5, *Dimensioning and tolerancing*.

Annex A of this International Standard is for information only.

<https://standards.iteh.ai/catalog/standards/sist/235f561d-d65f-4fdb-81c8-d6552825c793/sist-iso-10578-1995>

© ISO 1992

All rights reserved. No part of this publication may be reproduced or utilized in any form or by any means, electronic or mechanical, including photocopying and microfilm, without permission in writing from the publisher.

International Organization for Standardization
Case Postale 56 • CH-1211 Genève 20 • Switzerland

Printed in Switzerland

Introduction

A projected tolerance zone is used in conjunction with geometrical tolerancing to control or limit an extreme variation in the perpendicularity of threaded (or non-threaded) features, interference fit holes or similar features.

iTeh STANDARD PREVIEW (standards.iteh.ai)

[SIST ISO 10578:1995](https://standards.iteh.ai/catalog/standards/sist/235f561d-d65f-4fdb-81c8-d6552825c793/sist-iso-10578-1995)

<https://standards.iteh.ai/catalog/standards/sist/235f561d-d65f-4fdb-81c8-d6552825c793/sist-iso-10578-1995>

iTeh STANDARD PREVIEW
(standards.iteh.ai)

This page intentionally left blank

[SIST ISO 10578:1995](#)

<https://standards.iteh.ai/catalog/standards/sist/235f561d-d65f-4fdb-81c8-d6552825c793/sist-iso-10578-1995>

Technical drawings — Tolerancing of orientation and location — Projected tolerance zone

1 Scope

This International Standard defines the method of tolerancing by indication of a projected tolerance zone and specifies the method of indication.

2 Normative reference

The following standard contains provisions which through reference in this text, constitute provisions of this International Standard. At the time of publication, the edition indicated was valid. All standards are subject to revision, and parties to agreements based on this International Standard are encouraged to investigate the possibility of applying the most recent edition of the standard indicated below. Members of IEC and ISO maintain registers of currently valid International Standards.

ISO 1101:1983, *Technical drawings — Geometrical tolerancing — Tolerances of form, orientation, location and run-out — Generalities, definitions, symbols, indications on drawings*.

3 Definitions

For the purposes of this International Standard, the definitions given in ISO 1101 apply.

NOTE 1 The definition of the “minimum external projection of the feature” is under consideration and will be added at a later date to this International Standard.

4 Projected tolerance zone

The projected tolerance zone applies to the minimum external projection of the feature which is

- indicated on the drawing by the symbol \textcircled{P} followed by the projected dimension,
- represented by a chain thin double-dashed line in the corresponding drawing view, and
- indicated in the tolerance frame by the symbol \textcircled{P} placed after the tolerance of the tolerated feature.

See figure 1.

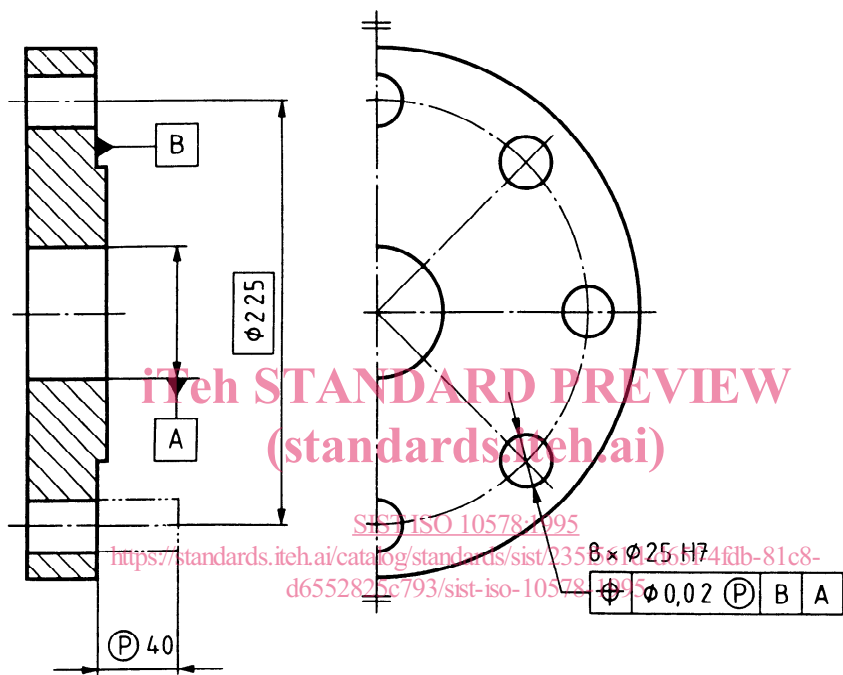

Figure 1

Annex A (informative)

Examples of indication on drawings, interpretation and functional length

A.1 Indication and interpretation

Consider the example of a screw 3 passing through a part 2 and fastening into a part 1, as shown in figure A.1.

The specification of the part 1 is given in figure A.2 a) and the corresponding interpretation is given in figure A.2 b).

The position of the axis of the threaded hole in part 1 (see figure A.3) shows that it would be impossible to insert the screw. There are a number of possible ways to eliminate this interference as follows.

a) The hole size of part 2 could be increased as shown in figure A.4 but this solution may not be

feasible if the functional conditions relating to shouldering or centring do not permit it.

b) The tolerance for part 1 could be tightened but this may increase the cost of the part.

c) An additional tolerance could be specified, for example a perpendicularity tolerance of smaller value than the location tolerance, but this also increases the cost of the part.

d) Alternatively a projected tolerance zone may be specified as shown in figure A.5 b). This allows for a maximum tolerance while ensuring assembly [see figure A.5 a)]. The interpretation is given in figure A.5 c).

STANDARD PREVIEW
(standards.iteh.ai)

SIST ISO 10578:1995

<https://standards.iteh.ai/catalog/standards/sist/235f561d-d65f-4fdb-81c8-d6552825c790/iso-10578-1995>

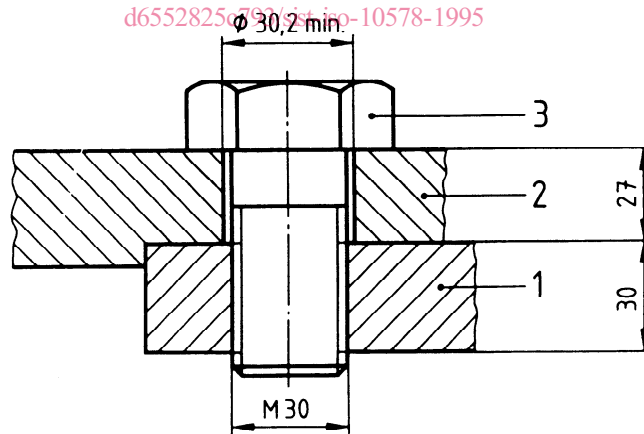

Figure A.1