



SLOVENSKI STANDARD
SIST ISO 10579:1995

01-junij-1995

HM b] bYf]gVY!`? c]f]Ub`Y]b`lc`Yf]f]Ub`Y]`8 Y]ž_]b]gc`lc[]

Technical drawings -- Dimensioning and tolerancing -- Non-rigid parts

Dessins techniques -- Cotation et tolérancement -- Pièces non rigides

Ta slovenski standard je istoveten z: ISO 10579:1993

[SIST ISO 10579:1995](https://standards.iteh.ai/catalog/standards/sist/29533b79-dd00-4fc9-89d4-7da5f29001c4/sist-iso-10579-1995)

<https://standards.iteh.ai/catalog/standards/sist/29533b79-dd00-4fc9-89d4-7da5f29001c4/sist-iso-10579-1995>

ICS:

01.100.20	Konstrukcijske risbe	Mechanical engineering drawings
-----------	----------------------	---------------------------------

SIST ISO 10579:1995

en

iTeh STANDARD PREVIEW
(standards.iteh.ai)

SIST ISO 10579:1995

<https://standards.iteh.ai/catalog/standards/sist/29533b79-dd00-4fc9-89d4-7da5f29001c4/sist-iso-10579-1995>

INTERNATIONAL STANDARD

ISO
10579

First edition
1993-02-01

Technical drawings — Dimensioning and tolerancing — Non-rigid parts

iTeh STANDARD PREVIEW
(standards.iteh.ai)

Dessins techniques — Cotation et tolérancement — Pièces non rigides

SIST ISO 10579:1995

<https://standards.iteh.ai/catalog/standards/sist/29533b79-dd00-4fc9-89d4-7da5f29001c4/sist-iso-10579-1995>



Reference number
ISO 10579:1993(E)

ISO 10579:1993(E)**Foreword**

ISO (the International Organization for Standardization) is a worldwide federation of national standards bodies (ISO member bodies). The work of preparing International Standards is normally carried out through ISO technical committees. Each member body interested in a subject for which a technical committee has been established has the right to be represented on that committee. International organizations, governmental and non-governmental, in liaison with ISO, also take part in the work. ISO collaborates closely with the International Electrotechnical Commission (IEC) on all matters of electrotechnical standardization.

Draft International Standards adopted by the technical committees are circulated to the member bodies for voting. Publication as an International Standard requires approval by at least 75 % of the member bodies casting a vote.

International Standard ISO 10579 was prepared by Technical Committee ISO/TC 10, *Technical drawings, product definition and related documentation*, Sub-Committee SC 5, *Dimensioning and tolerancing*.

Annexes A and B of this International Standard are for information only.

© ISO 1993

All rights reserved. No part of this publication may be reproduced or utilized in any form or by any means, electronic or mechanical, including photocopying and microfilm, without permission in writing from the publisher.

International Organization for Standardization
Case Postale 56 • CH-1211 Genève 20 • Switzerland

Printed in Switzerland

Introduction

Certain parts, when removed from their manufacturing environment, may deform significantly from their defined limits owing to their weight, flexibility or the release of internal stresses resulting from the manufacturing processes.

These parts are defined as “non-rigid parts” and the deformation is acceptable provided that the parts may be brought within the indicated tolerance by applying reasonable force to facilitate inspection and assembly .

Depending on the design function and the part’s interface with its mating components, instead of, or in addition to, assessing the part conventionally (in its free state condition), it may be necessary to assess the part when subject to restraint that is no greater than those accepted in the assembled condition.

Parts in this category include both those of inherently rigid material (such as thin metal parts) and those of inherently flexible material (such as rubber, plastics, etc.).

<https://standards.iteh.ai/catalog/standards/sist/29533b79-dd00-4fc9-89d4-7da5f29001c4/sist-iso-10579-1995>

iTeh STANDARD PREVIEW
(standards.iteh.ai)

This page intentionally left blank

[SIST ISO 10579:1995](#)

<https://standards.iteh.ai/catalog/standards/sist/29533b79-dd00-4fc9-89d4-7da5f29001c4/sist-iso-10579-1995>

Technical drawings — Dimensioning and tolerancing — Non-rigid parts

1 Scope

This International Standard gives rules for dimensioning and tolerancing non-rigid parts where restraining of features is required during verification of dimensions and tolerances specified on a drawing.

2 Normative reference

The following standard contains provisions which, through reference in this text, constitute provisions of this International Standard. At the time of publication, the edition indicated was valid. All standards are subject to revision, and parties to agreements based on this International Standard are encouraged to investigate the possibility of applying the most recent edition of the standard indicated below. Members of IEC and ISO maintain registers of currently valid International Standards.

ISO 1101:1983, *Technical drawings — Geometrical tolerancing — Tolerances of form, orientation, location and run-out — Generalities, definitions, symbols, indications on drawings*.

3 Definitions

For the purposes of this International Standard, the following definitions apply.

3.1 non-rigid part: Part which deforms to an extent that in the free state is beyond the dimensional and/or geometrical tolerances on the drawing.

3.2 free state: Condition of a part subjected only to the force of gravity.

4 Basic principles

The distortion of a non-rigid part must not exceed that which allows the part to be brought within specified tolerances for verification and positioning at assembly, or assembled, by applying pressure or forces not exceeding those which can be expected under normal assembly conditions. It is impossible to avoid the effect of natural forces such as gravity; but the extent of distortion may depend upon the orientation of the part and condition of the part in the free state. If it is necessary to indicate the geometrical tolerance in the free state, the conditions under which the tolerance is to be achieved (i.e. the direction of gravity, conditions in which it is to be supported, etc.) may have to be indicated in a note, as shown in annex A. For non-rigid parts, identified on the drawing by the added statement "ISO 10579-NR", the restrained condition applies unless the dimensions and tolerances are qualified by the symbol $\text{\textcircled{F}}$, see clause 5.

5 Indications on drawings

Drawings of non-rigid parts shall include the following indications as appropriate (see also annex A):

- in or near the title block, the indication "ISO 10579-NR";
- in a note, the conditions under which the part shall be restrained to meet the drawing requirements;
- geometrical variations allowed in the free state, with the modifying symbol $\text{\textcircled{F}}$ included in the tolerance frame in accordance with ISO 1101;
- the conditions under which the geometrical tolerance under free state is achieved, such as direction of gravity, orientation of the part, etc.

Annex A (informative)

Examples of indication and interpretation

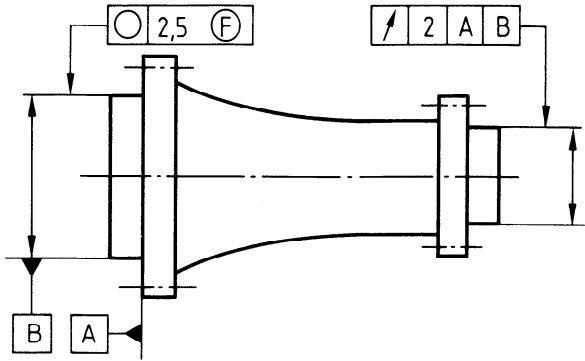
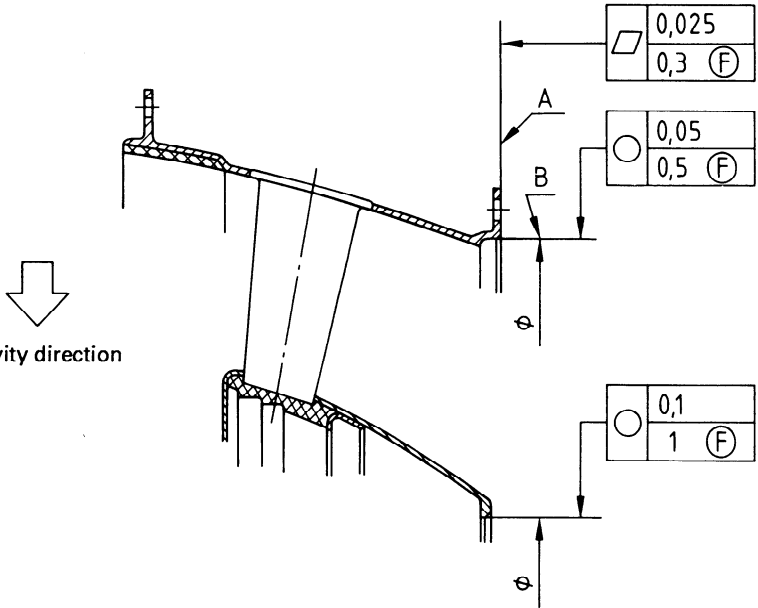
Indication on the drawing	Interpretation
 <p>ISO 10579-NR</p> <p>Restrained condition: The surface indicated as datum A is mounted (with 64 bolts M6 tightened to a torque of 9 N·m to 15 N·m) and the feature indicated as datum B is restrained at the corresponding maximum material limit.</p>	<p>The geometrical tolerance, followed by the symbol \textcircled{F}, shall be ensured in the free state. Other geometrical tolerances apply under the conditions indicated in the note.</p>
 <p>ISO 10579-NR</p> <p>Restrained condition: The surface indicated as datum A is mounted (with 120 bolts M20 tightened to a torque of 18 N·m to 20 N·m) and the feature indicated as datum B is restrained at the corresponding maximum material limit.</p>	<p>The geometrical tolerances, followed by the symbol \textcircled{F}, shall be ensured in the free state. Other geometrical tolerances apply under the conditions indicated in the note.</p>