



SLOVENSKI STANDARD

SIST EN 24506:2000

01-december-2000

Hardmetals - Compression test (ISO 4506:1979)

Hardmetals - Compression test (ISO 4506:1979)

Hartmetalle - Druckversuch (ISO 4506:1979)

Métaux-durs - Essai de compression (ISO 4506:1979)

Ta slovenski standard je istoveten z: **EN 24506:1993**

[SIST EN 24506:2000](https://standards.iteh.ai/catalog/standards/sist/a00fd5f9-bf70-4b16-a6f7-676a263b09e7/sist-en-24506-2000)

<https://standards.iteh.ai/catalog/standards/sist/a00fd5f9-bf70-4b16-a6f7-676a263b09e7/sist-en-24506-2000>

ICS:

77.040.10	Mehansko preskušanje kovin	Mechanical testing of metals
77.160	Metalurgija prahov	Powder metallurgy

SIST EN 24506:2000

en

iTeh STANDARD PREVIEW
(standards.iteh.ai)

SIST EN 24506:2000

<https://standards.iteh.ai/catalog/standards/sist/a00fd5f9-bf70-4b16-a6f7-676a263b09e7/sist-en-24506-2000>

EUROPEAN STANDARD

EN 24506:1993

NORME EUROPÉENNE

EUROPÄISCHE NORM

April 1993

UDC 669.018.25:620.173

Descriptors: Powder metallurgy, hard metals, mechanical tests, compression tests, elastic limit, designation

English version

Hardmetals - Compression test (ISO 4506:1979)Métaux-durs - Essai de compression Hardmetalle - Druckversuch (ISO 4506:1979)
(ISO 4506:1979)**STANDARD PREVIEW**
(standards.iteh.ai)SIST EN 24506:2000<https://standards.iteh.ai/catalog/standards/sist/a00fd59-bf70-4b16-a6f7-676a263b09e7/sist-en-24506-2000>

This European Standard was approved by CEN on 1993-04-02. CEN members are bound to comply with the CEN/CENELEC Internal Regulations which stipulate the conditions for giving this European Standard the status of a national standard without any alteration.

Up-to-date lists and bibliographical references concerning such national standards may be obtained on application to the Central Secretariat or to any CEN member.

The European Standards exist in three official versions (English, French, German). A version in any other language made by translation under the responsibility of a CEN member into its own language and notified to the Central Secretariat has the same status as the official versions.

CEN members are the national standards bodies of Austria, Belgium, Denmark, Finland, France, Germany, Greece, Iceland, Ireland, Italy, Luxembourg, Netherlands, Norway, Portugal, Spain, Sweden, Switzerland and United Kingdom.

CENEuropean Committee for Standardization
Comité Européen de Normalisation
Europäisches Komitee für Normung

Central Secretariat: rue de Stassart, 36 B-1050 Brussels

Page 2
EN 24506:1993

Foreword

In 1992 ISO 4506:1979 "Hardmetals - Compression test" was submitted to the CEN Primary Questionnaire procedure.

Following the positive result of the CEN/CS Proposal ISO 4506:1979 was submitted to the CEN Formal Vote. The result of the Formal Vote was positive.

This European Standard shall be given the status of a national standard, either by publication of an identical text or by endorsement, at the latest by October 1993, and conflicting national standards shall be withdrawn at the latest by October 1993.

According to the Internal Regulations of CEN/CENELEC, the following countries are bound to implement this European Standard :

Austria, Belgium, Denmark, Finland, France, Germany, Greece, Iceland, Ireland, Italy, Luxembourg, Netherlands, Norway, Portugal, Spain, Sweden, Switzerland and United Kingdom.

iTeh STANDARD PREVIEW
(standards.iteh.ai)

Endorsement notice

The text of the International Standard **ISO 4506:1979** was approved by CEN as a European Standard without any modification.

International Standard



4506

INTERNATIONAL ORGANIZATION FOR STANDARDIZATION • МЕЖДУНАРОДНАЯ ОРГАНИЗАЦИЯ ПО СТАНДАРТИЗАЦИИ • ORGANISATION INTERNATIONALE DE NORMALISATION

Hardmetals — Compression test

Métaux-durs — Essai de compression

First edition — 1979-10-15

iTeh STANDARD PREVIEW
(standards.iteh.ai)

[SIST EN 24506:2000](#)

<https://standards.iteh.ai/catalog/standards/sist/a00fd5f9-bf70-4b16-a6f7-676a263b09e7/sist-en-24506-2000>

UDC 621.762 : 661.665.2 : 620.173

Ref. No. ISO 4506-1979 (E)

Descriptors : hardmetals, mechanical tests, compression tests, proof stress, designation.

Foreword

ISO (the International Organization for Standardization) is a worldwide federation of national standards institutes (ISO member bodies). The work of developing International Standards is carried out through ISO technical committees. Every member body interested in a subject for which a technical committee has been set up has the right to be represented on that committee. International organizations, governmental and non-governmental, in liaison with ISO, also take part in the work.

Draft International Standards adopted by the technical committees are circulated to the member bodies for approval before their acceptance as International Standards by the ISO Council.

International Standard ISO 4506 was developed by Technical Committee ISO/TC 119, *Powder metallurgical materials and products*, and was circulated to the member bodies in July 1978.

It has been approved by the member bodies of the following countries:

Austria	Italy	Sweden
Bulgaria	Japan	United Kingdom
Czechoslovakia	Mexico	USA
Egypt, Arab Rep. of	Poland	USSR
France	Portugal	Yugoslavia
Ireland	Romania	

The member body of the following country expressed disapproval of the document on technical grounds :

Germany, F. R.

Hardmetals – Compression test

1 Scope and field of application

This International Standard specifies a method of determining the ultimate strength and proof stress of hardmetals under uniaxial compressive loads.

2 Principle

Axial loading of a test piece, placed between two hardmetal bearing blocks, until the intended deformation occurs or until the test piece fractures.

3 Symbols and designations

Symbol	Designation	Unit
S_0	Minimum original cross-sectional area	mm ²
F_c	(with index) Load at proof stress, for example :	
$F_{c 0,2}$	Load at 0,2 % proof stress	N
F_{cu}	Ultimate load, i.e. load at instant of fracture	N
R	Stress	N/mm ²
ϵ_c	Strain	%
E	Young's modulus	N/mm ²
R_c	(with index) Proof stress, for example :	
$R_{c 0,2}$	0,2 % proof stress	N/mm ²
R_{cm}	Ultimate compressive strength	N/mm ²

4 Apparatus

The test machine shall be designed and constructed so that loads can be applied at a uniform rate and so that, within the measuring range in question, the maximum loading error will be $\pm 1\%$.

The test piece shall be affixed between two well-centred and rigidly secured hardmetal anvils with a hardness not less than 1 600 HV. These contact surfaces shall be perpendicular to the loading axis and parallel to each other within 0,5 $\mu\text{m}/\text{mm}$. An example of a suitable anvil is given in figure 1.

5 Test piece

5.1 The dimensions of the test piece shall conform to figure 2. The end faces and the cylindrical surfaces of the enlarged ends shall be ground. Other surfaces should not be ground. (Grinding or polishing may affect the result of the test.)¹⁾

5.2 The minimum diameter of the test piece shall be measured with an accuracy of $\pm 0,02\text{ mm}$.

6 Procedure

6.1 Rate of stress increase

The rate at which the load is applied shall be as uniform as possible, and any changes in this rate shall be made gradually and without shock. The rate shall not exceed 8 000 N/s, corresponding approximately to 100 N/(mm².s).

1) Cylindrical test pieces such as those specified in ASTM E9-1977 or USSR TU-48-19-280-78 may be used to obtain results with potentially less accuracy.

ISO 4506-1979 (E)

6.2 Determination of proof stress

6.2.1 The proof stress, for example the 0,2 % proof stress, is determined according to figure 3. This method is based on the fact, valid for almost all metals, that if a load is removed after the elastic limit, D , has been exceeded, the load-compression curve will follow a linear path that is roughly parallel to the loading curve below the elastic limit.

6.2.2 Determination of proof stress using the graphic intersection method is carried out as follows.

6.2.2.1 Apply a pre-load not greater than that required to keep the test piece positioned properly in the machine.

6.2.2.2 Determine the stress-strain curve.

NOTE — Because of the shortness of the test zone and the hardness of the material, practical difficulties are involved in measuring changes in length using displacement gauges of the clamp-on type (extensometers). It is therefore recommended that changes in length be measured using a resistive strain gauge. Two or four gauges should be applied symmetrically at the centre of the test zone. The active length of the gauges should not exceed 8 mm. The results obtained represent an average of the change in length of the test zone.

6.2.2.3 On the graph thus plotted (figure 3), make OB equal to the specified residual strain (offset), and draw a line BA from B parallel to OC . Ordinate F_c of intersection point Q has the value F_{cq} and represents the load that corresponds to the proof stress.

It is sometimes difficult to ascertain the direction of line OC from a graph; in such a case, this line can be drawn on the basis of an agreed value of the Young's modulus.

6.2.3 The proof stress R_{cq} , in newtons per square millimetre, is given by the formula

$$R_{cq} = \frac{F_{cq}}{S_0}$$

6.3 Determination of ultimate compressive strength

6.3.1 Load the test piece to fracture.

6.3.2 The ultimate compressive strength R_{cm} , in newtons per square millimetre, is given by the formula

$$R_{cm} = \frac{F_{cu}}{S_0}$$

7 Expression of results

Report the arithmetical mean of at least five determinations, rounded to the nearest 10 N/mm².

8 Test report

The test report shall include the following informations :

- a) reference to this International Standard;
- b) all details necessary for identification of the test piece;
- c) the result obtained;
- d) all operations not specified by this International Standard, or regarded as optional;
- e) details of any occurrence which may have affected the result.

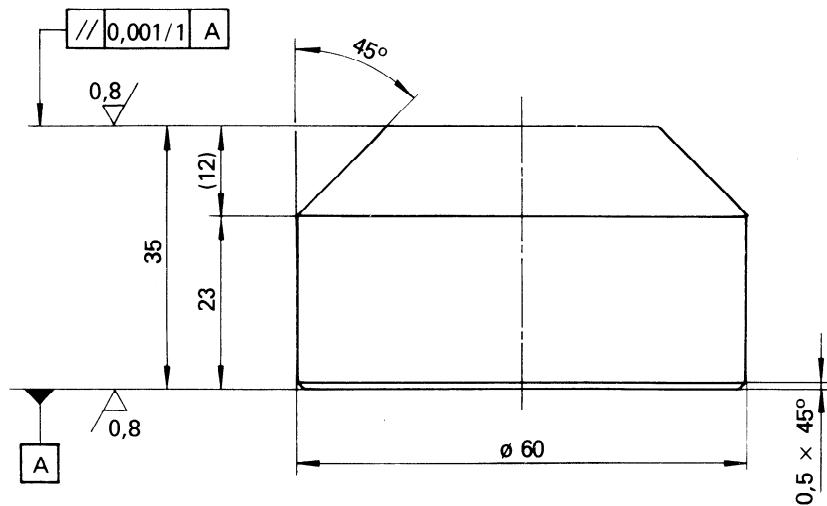
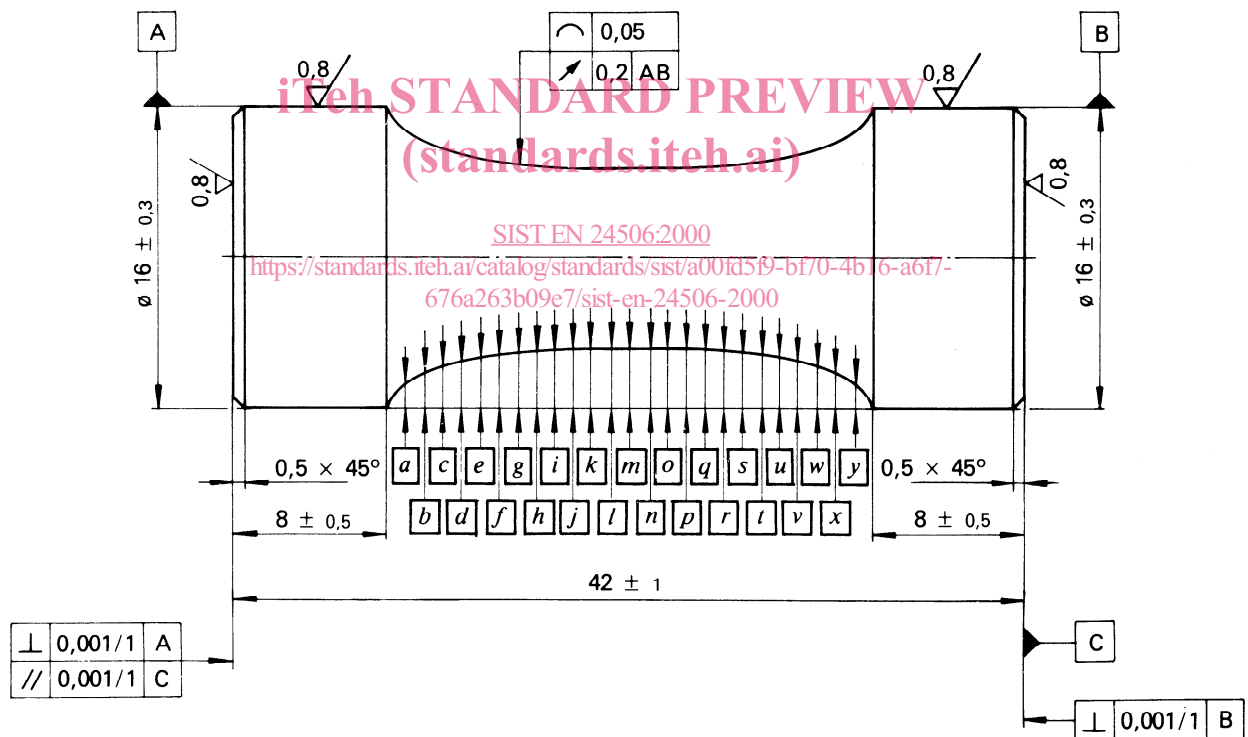

Figure 1 – Suitable hardmetal anvil



a	b	c	d	e	f	g	h	i	j	k	l
1,21	1,90	2,29	2,54	2,69	2,79	2,86	2,91	2,94	2,96	2,98	2,99

m	n	o	p	q	r	s	t	u	v	w	x	y
3,00	2,99	2,98	2,96	2,94	2,91	2,86	2,79	2,69	2,54	2,29	1,90	1,21

Figure 2 – Test piece (The 25 co-ordinates a to y are at 1 mm intervals)