

CORRIGENDUM 1

Figure 3

Replace "4,6" by "5,2", as follows:

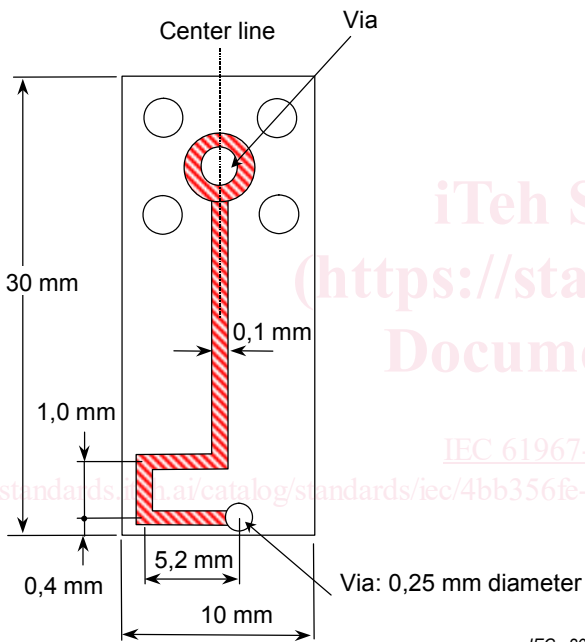

Figure 3 – Magnetic probe – Second layer

A.4 Calibration

Equation A.1

Replace "30" by "34", as follows:

$$C_{f_dB} = 20 \log \left[\frac{h}{\pi Y(Y + 2h)} \right] - V_{p_dB} + V_{s_dB} - 34 \quad (\text{dB S/m}) \quad (\text{A.1})$$

Figure 3

Remplacer "4,6" par "5,2", comme suit:

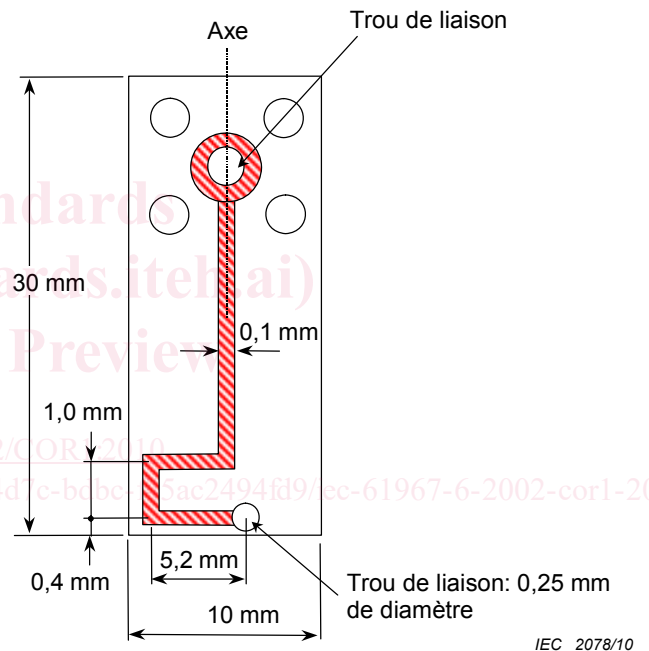

Figure 3 – Deuxième couche de la sonde magnétique

A.4 Etalonnage

Equation A.1

Remplacer "30" par "34", comme suit: