**Hexagon nuts with flange — Fine pitch
thread**

Écrous hexagonaux à embase cylindro-tronconique — Filetage à pas fin

iTeh STANDARD PREVIEW
(standards.iteh.ai)

[ISO 10663:1999](https://standards.iteh.ai/catalog/standards/sist/e9f38535-f8c1-470f-b2fa-f38179dfe19b/iso-10663-1999)

<https://standards.iteh.ai/catalog/standards/sist/e9f38535-f8c1-470f-b2fa-f38179dfe19b/iso-10663-1999>



Foreword

ISO (the International Organization for Standardization) is a worldwide federation of national standards bodies (ISO member bodies). The work of preparing International Standards is normally carried out through ISO technical committees. Each member body interested in a subject for which a technical committee has been established has the right to be represented on that committee. International organizations, governmental and non-governmental, in liaison with ISO, also take part in the work. ISO collaborates closely with the International Electrotechnical Commission (IEC) on all matters of electrotechnical standardization.

Draft International Standards adopted by the technical committees are circulated to the member bodies for voting. Publication as an International Standard requires approval by at least 75 % of the member bodies casting a vote.

International Standard ISO 10663 was prepared by Technical Committee ISO/TC 2, *Fasteners*.

Annex A forms an integral part of this International Standard.

iTeh STANDARD PREVIEW (standards.iteh.ai)

ISO 10663:1999

<https://standards.iteh.ai/catalog/standards/sist/e9f38535-f8c1-470f-b2fa-f38179dfe19b/iso-10663-1999>

© ISO 1999

All rights reserved. Unless otherwise specified, no part of this publication may be reproduced or utilized in any form or by any means, electronic or mechanical, including photocopying and microfilm, without permission in writing from the publisher.

International Organization for Standardization
Case postale 56 • CH-1211 Genève 20 • Switzerland
Internet iso@iso.ch

Printed in Switzerland

Hexagon nuts with flange — Fine pitch thread

1 Scope

This International Standard specifies the characteristics of hexagon nuts with flange and metric fine pitch thread with nominal thread diameters from 8 mm to 20 mm, in product grade A for $d \leq 16$ mm and product grade B for $d > 16$ mm.

If, in special cases, specifications other than those listed in this International Standard are required, they should be selected from existing International Standards, for example ISO 261, ISO 898-6, ISO 965-2, ISO 3506-2.

2 Normative references

The following standards contain provisions which, through reference in this text, constitute provisions of this International Standard. At the time of publication, the editions indicated were valid. All standards are subject to revision, and parties to agreements based on this International Standard are encouraged to investigate the possibility of applying the most recent editions of the standards indicated below. Members of IEC and ISO maintain registers of currently valid International Standards.

(standards.iteh.ai)

ISO 225:1983, *Fasteners — Bolts, screws, studs and nuts — Symbols and designations of dimensions.*

ISO 261:1998, *ISO general purpose metric screw threads — General plan.*

ISO 898-6:1994, *Mechanical properties of fasteners — Part 6: Nuts with specified proof load values — Fine pitch thread.*

ISO 965-2:1998, *ISO general purpose metric screw threads — Tolerances — Part 2: Limits of sizes for general purpose external and internal screw threads — Medium quality.*

ISO 3269:—¹⁾, *Fasteners — Acceptance inspection.*

ISO 3506-2:1997, *Mechanical properties of corrosion-resistant stainless-steel fasteners — Part 2: Nuts.*

ISO 4042:—²⁾, *Fasteners — Electroplated coatings.*

ISO 4759-1:—³⁾, *Tolerances for fasteners — Part 1: Bolts, screws, studs and nuts — Product grades A, B and C.*

ISO 6157-2:1995, *Fasteners — Surface discontinuities — Part 2: Nuts.*

ISO 8992:1986, *Fasteners — General requirements for bolts, screws, studs and nuts.*

¹⁾ To be published. (Revision of ISO 3269:1988)

²⁾ To be published. (Revision of ISO 4042:1989)

³⁾ To be published. (Revision of ISO 4759-1:1978)

3 Dimensions

See Figure 1 and Table 1.

Symbols and designations of dimensions are specified in ISO 225.

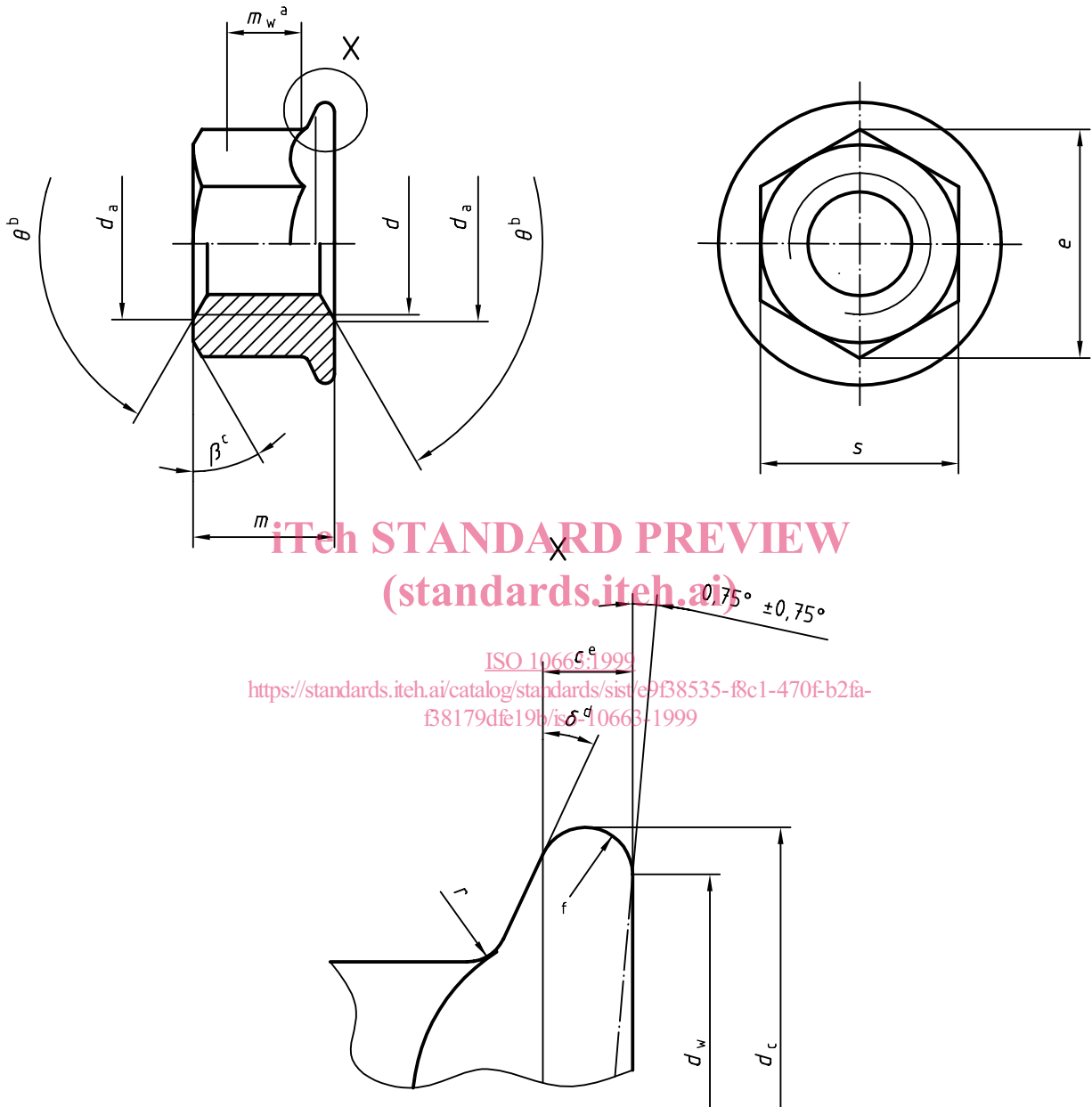

a m_w is the wrenching height; see note to Table 1

b $\theta = 90^\circ$ to 120°

c $\beta = 15^\circ$ to 30°

d $\delta = 15^\circ$ to 25°

e c is measured at $d_{w, \min}$

f Edge contour optional

Figure 1

Table 1 — Dimensions

Dimensions in millimetres

Thread ($d \times P^a$)		M8 × 1	M10 × 1,25 (M10 × 1) ^b	M12 × 1,25 (M12 × 1,5) ^b	(M14 × 1,5) ^b	M16 × 1,5	M20 × 1,5
c	min.	1,2	1,5	1,8	2,1	2,4	3
d_a	max.	8,75	10,8	13	15,1	17,3	21,6
	min.	8,00	10,0	12	14,0	16,0	20,0
d_c	max.	17,9	21,8	26	29,9	34,5	42,8
d_w	min.	15,8	19,6	23,8	27,6	31,9	39,9
e	min.	14,38	16,64	20,03	23,36	26,75	32,95
m	max.	8,00	10,00	12,00	14,0	16,0	20,0
	min.	7,64	9,64	11,57	13,3	15,3	18,7
m_w	min.	4,6	5,6	6,8	7,7	8,9	10,7
s	max.	13,00	15,00	18,00	21,00	24,00	30,00
	min.	12,73	14,73	17,73	20,67	23,67	29,16
r^c	max.	0,5	0,6	0,7	0,9	1	1,2

NOTE If the product passes the gauging given in annex A, the requirements for dimensions e , c and m_w are satisfied.

^a P is the pitch of the thread.

^b The sizes in parentheses should be avoided if possible.

^c Radius r applies both at the corners and the flats of the hexagon.

4 Requirements and reference International Standards

See Table 2.

Table 2 — Requirements and reference International Standards

Material		Steel				Stainless steel
General requirements	International Standard	ISO 8992				
	Tolerance	6H				
Thread	International Standards	ISO 261, ISO 965-2				
	Property class	8		10	12	A2-70
Mechanical properties	Style decisive for mechanical properties ^a	$d \leq 16$ mm style 2	$d > 16$ mm style 1	style 2	$d \leq 16$ mm ^b style 2	
	International Standards	ISO 898-6				ISO 3506-2
Tolerances	Product grade	$d \leq 16$ mm: A $d > 16$ mm: B				
	International Standard	ISO 4759-1				
Finish		As processed				Plain
		Requirements for electroplating are covered in ISO 4042. If different electroplating requirements are desired or if requirements are needed for other finishes, they shall be agreed between supplier and customer. Limits for surface discontinuities are covered in ISO 6157-2.				
Acceptability	For acceptance procedure, see ISO 3269.					

^a Based on the nut height (dimension m_{min}) nuts to this International Standard are of style 2. However, since for style 2, ISO 898-6 does not specify mechanical properties for all property classes and sizes as specified in this International Standard, in some cases nuts have to be tested according to style 1.

^b For $d > 16$ mm property class 12 is not specified.

5 Designation

EXAMPLE

A hexagon nut with flange, with thread M12 × 1,25 and property class 10 is designated as follows:

Hexagon nut with flange ISO 10663 – M12 × 1,25 – 10

Annex A (normative)

Gauging of hexagon flange nuts

A.1 Recommended method for gauging of hexagon

See Figure A.1 and Table A.1.

The nut shall be gauged using two plain ring gauges, A and B, to demonstrate the coincidental acceptability of hexagon height, corner fill and width across corners. Gauge A shall be placed over the nut and shall be seated on the flange. Gauge B shall be placed on the top of the nut normal to the nut axis. The two gauges shall not be in contact.

A.2 Recommended method for gauging of flange thickness

See Figure A.1 and Table A.1.

Gauge C is a flat feeler or ring gauge. It is used to prove that the flange thickness at the junction of the gauge with the hexagon portion is equal to or greater than specified values. The acceptance criterion is that gauge C will fit under gauge A without contact when the nut is seated on a flat plate.

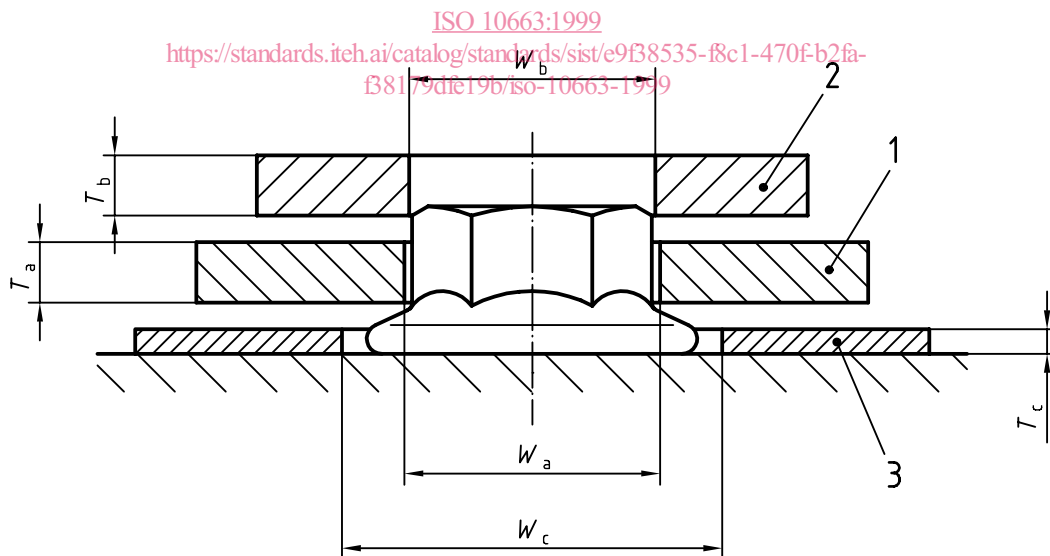

NOTE $W_{a, \min} = e_{\text{theoretical}}$
 $W_{b, \max} = e_{\min} - 0,01 \text{ mm}$
 $T_{a, \max} = m_{w, \min}$

Key

- 1 Gauge A
- 2 Gauge B
- 3 Gauge C

Figure A.1

Table A.1

Dimensions in millimetres

Nominal thread diameter (<i>d</i>)	Gauge A				Gauge B			Gauge C		
	W_a		T_a		W_b		T_b	W_c	T_c	
	max.	min.	max.	min.	max.	min.	min.	min.	max.	min.
8	15,02	15,01	4,60	4,59	14,37	14,36	4	20	1,31	1,30
10	17,33	17,32	5,60	5,59	16,63	16,62	5	24	1,81	1,80
12	20,79	20,78	6,80	6,79	20,02	20,01	5	29	2,20	2,19
14	24,26	24,25	7,70	7,69	23,35	23,34	6	32,5	2,55	2,54
16	27,72	27,71	8,90	8,89	26,74	26,73	6	37	2,96	2,95
20	34,65	34,64	10,70	10,69	32,94	32,93	6	45	3,70	3,69

iTeh STANDARD PREVIEW
(standards.iteh.ai)

ISO 10663:1999

<https://standards.iteh.ai/catalog/standards/sist/e9f38535-f8c1-470f-b2fa-f38179dfe19b/iso-10663-1999>

iTeh STANDARD PREVIEW
(standards.iteh.ai)

ISO 10663:1999

<https://standards.iteh.ai/catalog/standards/sist/e9f38535-f8c1-470f-b2fa-f38179dfe19b/iso-10663-1999>