**Drilling screws with tapping screw thread —
Mechanical and functional properties**

*Vis autoperceuses avec filetage de vis à tôle — Caractéristiques mécaniques
et fonctionnelles*

iTeh Standards
(<https://standards.itih.ai>)
Document Preview

[ISO 10666:1999](#)

<https://standards.itih.ai/catalog/standards/iso/14488739-8c51-4ca7-a740-428ccd4e1525/iso-10666-1999>



Foreword

ISO (the International Organization for Standardization) is a worldwide federation of national standards bodies (ISO member bodies). The work of preparing International Standards is normally carried out through ISO technical committees. Each member body interested in a subject for which a technical committee has been established has the right to be represented on that committee. International organizations, governmental and non-governmental, in liaison with ISO, also take part in the work. ISO collaborates closely with the International Electrotechnical Commission (IEC) on all matters of electrotechnical standardization.

International Standards are drafted in accordance with the rules given in the ISO/IEC Directives, Part 3.

Draft International Standards adopted by the technical committees are circulated to the member bodies for voting. Publication as an International Standard requires approval by at least 75 % of the member bodies casting a vote.

International Standard ISO 10666 was prepared by Technical Committee ISO/TC 2, *Fasteners*.

iTeh Standards (<https://standards.iteh.ai>) Document Preview

[ISO 10666:1999](#)

<https://standards.iteh.ai/catalog/standards/iso/14488739-8c51-4ca7-a740-428ccd4e1525/iso-10666-1999>

© ISO 1999

All rights reserved. Unless otherwise specified, no part of this publication may be reproduced or utilized in any form or by any means, electronic or mechanical, including photocopying and microfilm, without permission in writing from the publisher.

International Organization for Standardization
Case postale 56 • CH-1211 Genève 20 • Switzerland
Internet iso@iso.ch

Printed in Switzerland

Drilling screws with tapping screw thread — Mechanical and functional properties

1 Scope

This International Standard specifies the properties of heat treated screws with a tapping screw thread in accordance with ISO 1478, and which are designed with a drilling point which automatically drills the core hole for the screw during assembly. Such screws then automatically form the mating screw thread, either in a non-cutting or in a cutting operation, with the aid of the threaded portion of the screw adjoining the drilling point.

The purpose of this International Standard is to ensure that the screws are able to drill their core hole and form their mating screw thread without becoming distorted or fracturing in the process, provided that no overstressing has occurred. Consequently the following characteristics are regarded as representing the most important aspects for the assessment of the mechanical and operational characteristics of a drilling screw:

- surface hardness;
- capability of core hole drilling and forming of the mating female screw thread;
- torsional strength.

2 Normative references

The following normative documents contain provisions which, through reference in this text, constitute provisions of this International Standard. For dated references, subsequent amendments to, or revisions of, any of these publications do not apply. However, parties to agreements based on this International Standard are encouraged to investigate the possibility of applying the most recent editions of the normative documents indicated below. For undated references, the latest edition of the normative document referred to applies. Members of ISO and IEC maintain registers of currently valid International Standards.

ISO 1478:1999, *Tapping screw thread*.

ISO 4042:1999, *Fasteners — Electroplated coatings*.

ISO 6507-1:1997, *Metallic materials — Vickers hardness test — Part 1: Test method*.

ISO 15330:1999, *Fasteners — Preloading test for the detection of hydrogen embrittlement — Parallel bearing surface method*.

3 Requirements

3.1 Material

Case hardening steel or heat treatable steel shall be used as the material for drilling screws.

3.2 Metallurgical properties

3.2.1 Surface hardness

The minimum surface hardness of drilling screws after heat treatment shall be 530 HV 0,3.

3.2.2 Core hardness

The core hardness after heat treatment shall be

- 320 HV 5 to 400 HV 5 for threads \leq ST 4,2 and
- 320 HV 10 to 400 HV 10 for threads $>$ ST 4,2

including a recommended minimum tempering temperature of 330 °C.

The tempering temperature range 275 °C to 315 °C shall be avoided in order to minimize the risk of tempered martensite embrittlement.

3.2.3 Case depth

The case depth shall conform to the values given in Table 1.

Table 1 — Case depth

Thread	Case depth mm	
	min.	max.
ST 2,9 and ST 3,5	0,05	0,18
ST 4,2 to ST 5,5	0,10	0,23
ST 6,3	0,15	0,28

3.2.4 Microstructure

The microstructure of drilling screws shall not exhibit any ferrite streaks between the surface zone and the core after heat treatment.

3.2.5 Hydrogen embrittlement

For electroplated drilling screws there is a risk of failure due to hydrogen embrittlement. Therefore steps shall be taken by the manufacturer and/or the electroplater to manage the risk including test detection in accordance with ISO 15330.

In this connection ISO 4042, in which measures for hydrogen embrittlement relief are described for electroplated fasteners, shall also be consulted.

3.3 Mechanical properties

3.3.1 Core hole drilling capability

The point of the drilling screw shall be shaped in such a way that it is capable of drilling the necessary core hole for forming the mating female screw thread under the test conditions specified in 4.2.1.

3.3.2 Thread forming capability

Drilling screws shall be able to form a mating thread in the core hole drilled according to 3.3.1, without deforming their own thread when driven into a test plate in accordance with 4.2.1.1.

3.3.3 Torsional strength

Drilling screws shall have a torsional strength such that the torque necessary to cause failure, when tested in accordance with 4.2.3, shall equal or exceed the minimum torque values given in Table 4 for the applicable screw threads.

4 Testing

4.1 Testing of metallurgical properties

4.1.1 Testing of surface hardness

The surface hardness shall be tested by a Vickers procedure as specified in ISO 6507-1. The indentation shall be made on a portion of the screw as flat as possible, preferably on the head of the screw.

4.1.2 Testing of the core hardness

The core hardness shall be tested on a transverse micro-section by a with Vickers method as specified in ISO 6507-1.

4.1.3 Measuring the case depth

The case depth shall be measured microscopically on a longitudinal micro-section at the thread flank mid-point between crest and root or, in the case of drilling screws up to and including ST 4,2, in the root of the thread.

For referee purposes, a micro-hardness plot shall be made using a Vickers indenter and a 300 g load on the thread profile of a properly prepared metallographic specimen. The case depth shall be the point at which the recorded hardness is 30 HV above the actual core hardness.

4.1.4 Examination of the structure

The material microstructure shall be examined by metallography.

4.2 Testing of mechanical properties

4.2.1 Drilling and screwing-in-test

4.2.1.1 Test fixture

Figure 1 illustrates an example of a suitable test fixture.

The test plate shall be made from low carbon steel with a carbon content not exceeding 0,23 %. The hardness of the plate shall be 110 HV 30 to 165 HV 30 measured in accordance with ISO 6507-1. The thickness of the test plate shall conform to the values given in Table 2.

4.2.1.2 Test procedure

The sample screw (coated or uncoated, as received) shall be driven into the test plate until a thread of full diameter is completely through the test plate.

Axial forces and rotational speeds as specified in Table 2 shall be applied for the drilling and screwing-in-test.

4.2.2 Inspection of the drilled hole

Subject to mutual agreement, an inspection of the drilled hole may also be carried out. For this purpose, test plates in accordance with 4.2.1.1 but with thicknesses as given in Table 3 shall be used. The test plate shall be centered with a light punch mark at the spot to be drilled. After the test plate has been drilled through, the maximum size of the drilled hole shall not exceed the limits specified in Table 3.

Figure 2 illustrates a suitable testing arrangement as an addition to the test fixture illustrated in Figure 1. The inside diameter of the bush shall be approximately 0,25 mm larger than the outside diameter of the screw thread. The length of the bush shall be selected in such a way that the drilling point protrudes out of the bush.

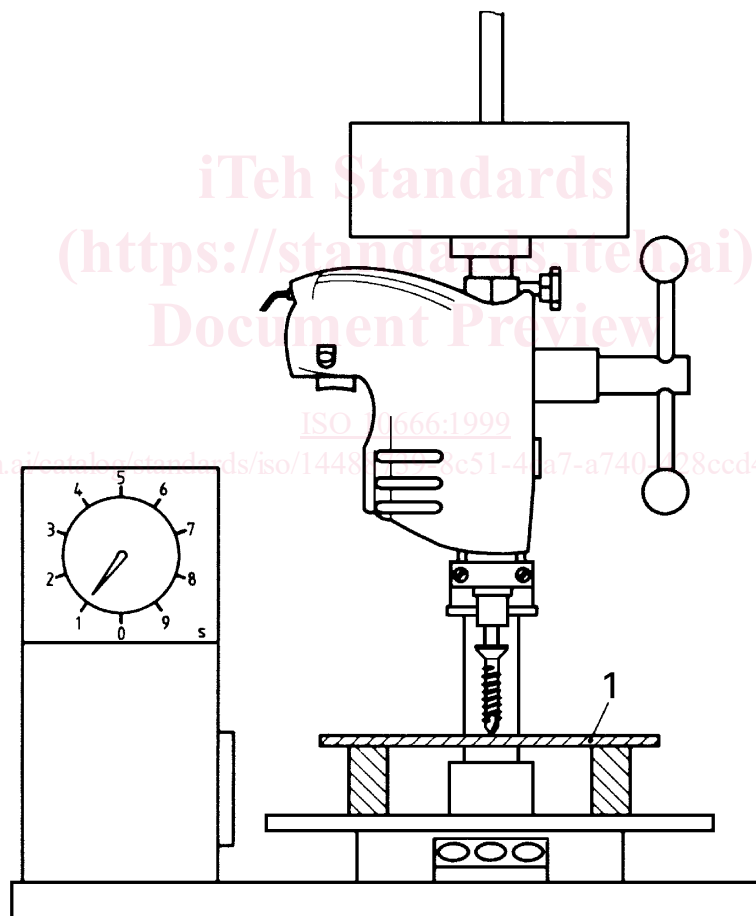

Key

1 Test plate

Figure 1 — Test fixture for the drilling and screwing-in-test