

INTERNATIONAL STANDARD

NORME INTERNATIONALE



**Industrial communication networks – Profiles –
Part 3-18: Functional safety fieldbuses – Additional specifications for CPF 18**

**Réseaux de communication industriels – Profils –
Partie 3-18: Bus de terrain de sécurité fonctionnelle – Spécifications
supplémentaires pour le CPF 18**

IEC 61784-3-18:2011

<https://standards.iteh.ai/standards/iec/ac3352fb-bd87-40f1-9671-7953c42fe5c2/iec-61784-3-18-2011>



THIS PUBLICATION IS COPYRIGHT PROTECTED

Copyright © 2016 IEC, Geneva, Switzerland

All rights reserved. Unless otherwise specified, no part of this publication may be reproduced or utilized in any form or by any means, electronic or mechanical, including photocopying and microfilm, without permission in writing from either IEC or IEC's member National Committee in the country of the requester. If you have any questions about IEC copyright or have an enquiry about obtaining additional rights to this publication, please contact the address below or your local IEC member National Committee for further information.

Droits de reproduction réservés. Sauf indication contraire, aucune partie de cette publication ne peut être reproduite ni utilisée sous quelque forme que ce soit et par aucun procédé, électronique ou mécanique, y compris la photocopie et les microfilms, sans l'accord écrit de l'IEC ou du Comité national de l'IEC du pays du demandeur. Si vous avez des questions sur le copyright de l'IEC ou si vous désirez obtenir des droits supplémentaires sur cette publication, utilisez les coordonnées ci-après ou contactez le Comité national de l'IEC de votre pays de résidence.

IEC Central Office
3, rue de Varembe
CH-1211 Geneva 20
Switzerland

Tel.: +41 22 919 02 11
Fax: +41 22 919 03 00
info@iec.ch
www.iec.ch

About the IEC

The International Electrotechnical Commission (IEC) is the leading global organization that prepares and publishes International Standards for all electrical, electronic and related technologies

About IEC publications

The technical content of IEC publications is kept under constant review by the IEC. Please make sure that you have the latest edition, a corrigenda or an amendment might have been published.

IEC Catalogue - webstore.iec.ch/catalogue

The stand-alone application for consulting the entire bibliographical information on IEC International Standards, Technical Specifications, Technical Reports and other documents. Available for PC, Mac OS, Android Tablets and iPad.

IEC publications search - www.iec.ch/searchpub

The advanced search enables to find IEC publications by a variety of criteria (reference number, text, technical committee,...). It also gives information on projects, replaced and withdrawn publications.

IEC Just Published - webstore.iec.ch/justpublished

Stay up to date on all new IEC publications. Just Published details all new publications released. Available online and also once a month by email.

Electropedia - www.electropedia.org

The world's leading online dictionary of electronic and electrical terms containing 20 000 terms and definitions in English and French, with equivalent terms in 15 additional languages. Also known as the International Electrotechnical Vocabulary (IEV) online.

IEC Glossary - std.iec.ch/glossary

65 000 electrotechnical terminology entries in English and French extracted from the Terms and Definitions clause of IEC publications issued since 2002. Some entries have been collected from earlier publications of IEC TC 37, 77, 86 and CISPR.

IEC Customer Service Centre - webstore.iec.ch/csc

If you wish to give us your feedback on this publication or need further assistance, please contact the Customer Service Centre: csc@iec.ch.

A propos de l'IEC

La Commission Electrotechnique Internationale (IEC) est la première organisation mondiale qui élabore et publie des Normes internationales pour tout ce qui a trait à l'électricité, à l'électronique et aux technologies apparentées.

A propos des publications IEC

Le contenu technique des publications IEC est constamment revu. Veuillez vous assurer que vous possédez l'édition la plus récente, un corrigendum ou amendement peut avoir été publié.

Catalogue IEC - webstore.iec.ch/catalogue

Application autonome pour consulter tous les renseignements bibliographiques sur les Normes internationales, Spécifications techniques, Rapports techniques et autres documents de l'IEC. Disponible pour PC, Mac OS, tablettes Android et iPad.

Recherche de publications IEC - www.iec.ch/searchpub

La recherche avancée permet de trouver des publications IEC en utilisant différents critères (numéro de référence, texte, comité d'études,...). Elle donne aussi des informations sur les projets et les publications remplacées ou retirées.

IEC Just Published - webstore.iec.ch/justpublished

Restez informé sur les nouvelles publications IEC. Just Published détaille les nouvelles publications parues. Disponible en ligne et aussi une fois par mois par email.

Electropedia - www.electropedia.org

Le premier dictionnaire en ligne de termes électroniques et électriques. Il contient 20 000 termes et définitions en anglais et en français, ainsi que les termes équivalents dans 15 langues additionnelles. Egalement appelé Vocabulaire Electrotechnique International (IEV) en ligne.

Glossaire IEC - std.iec.ch/glossary

65 000 entrées terminologiques électrotechniques, en anglais et en français, extraites des articles Termes et Définitions des publications IEC parues depuis 2002. Plus certaines entrées antérieures extraites des publications des CE 37, 77, 86 et CISPR de l'IEC.

Service Clients - webstore.iec.ch/csc

Si vous désirez nous donner des commentaires sur cette publication ou si vous avez des questions contactez-nous: csc@iec.ch.

INTERNATIONAL STANDARD

NORME INTERNATIONALE



**Industrial communication networks – Profiles –
Part 3-18: Functional safety fieldbuses – Additional specifications for CPF 18**

**Réseaux de communication industriels – Profils –
Partie 3-18: Bus de terrain de sécurité fonctionnelle – Spécifications
supplémentaires pour le CPF 18**

INTERNATIONAL
ELECTROTECHNICAL
COMMISSION

COMMISSION
ELECTROTECHNIQUE
INTERNATIONALE

ICS 13.110; 25.040.40, 35.100.05

ISBN 978-2-8322-3543-0

**Warning! Make sure that you obtained this publication from an authorized distributor.
Attention! Veuillez vous assurer que vous avez obtenu cette publication via un distributeur agréé.**

Withdrawing

iTech Standards
(<https://standards.iteh.ai>)
Document Preview

[IEC 61784-3-18:2011](#)

<https://standards.iteh.ai/catalog/standards/iec/ac3352fb-bd87-40f1-9671-7953c42fe5c2/iec-61784-3-18-2011>

REDLINE VERSION

VERSION REDLINE



**Industrial communication networks – Profiles –
Part 3-18: Functional safety fieldbuses – Additional specifications for CPF 18**

**Réseaux de communication industriels – Profils –
Partie 3-18: Bus de terrain de sécurité fonctionnelle – Spécifications
supplémentaires pour le CPF 18**

IEC 61784-3-18:2011

<https://standards.iteh.ai/standards/iec/ac3352fb-bd87-40f1-9671-7953c42fe5c2/iec-61784-3-18-2011>

CONTENTS

FOREWORD.....	5
0 Introduction.....	7
0.1 General.....	7
0.2 Patent declaration.....	9
1 Scope.....	10
2 Normative references.....	10
3 Terms, definitions, symbols, abbreviated terms and conventions.....	11
3.1 Terms and definitions.....	11
3.1.1 Common terms and definitions.....	11
3.1.2 CPF 18: Additional terms and definitions.....	15
3.2 Symbols and abbreviated terms.....	16
3.2.1 Common symbols and abbreviated terms.....	16
3.2.2 CPF 18: Additional symbols and abbreviated terms.....	17
3.3 Conventions.....	17
4 Overview of FSCP 18/1 (SafetyNET p™).....	19
4.1 General.....	19
4.2 FSCP 18/1.....	19
5 General.....	20
5.1 External documents providing specifications for the profile.....	20
5.2 Safety functional requirements.....	20
5.3 Safety measures.....	21
5.4 Safety communication layer structure.....	21
5.5 Relationships with FAL (and DLL, PhL).....	22
5.5.1 General.....	22
5.5.2 Data Types.....	22
6 Safety communication layer services.....	22
6.1 General elements.....	22
6.1.1 General.....	22
6.1.2 Safety object dictionary.....	22
6.1.3 Safety process data object (SPDO).....	22
6.1.4 Safety heartbeat (SHB).....	22
6.1.5 Safety delay monitoring (SDM).....	23
6.2 Communication relation.....	23
7 Safety communication layer protocol.....	24
7.1 Safety PDU format.....	24
7.1.1 General.....	24
7.1.2 Safety process data objects (SPDO).....	24
7.1.3 Safety heartbeat (SHB).....	26
7.1.4 Safety PDUs embedded in a Type 22 PDU.....	29
7.2 Safety communication layer management (SALMT).....	29
7.3 Safety process data communication.....	31
7.4 Safety heartbeat.....	33
7.5 Delay monitoring.....	34
8 Safety communication layer management.....	35
8.1 Parameter handling.....	35

8.2	Safety object dictionary.....	35
8.2.1	General	35
8.2.2	Communication profile section.....	36
8.2.3	Standardized device profile section	52
9	System requirements	52
9.1	Indicators and switches	52
9.1.1	Indicator states and flash rates.....	52
9.1.2	Indicators.....	53
9.1.3	Switches.....	53
9.2	Installation guidelines	53
9.3	Safety function response time	53
9.3.1	General	53
9.3.2	Determination of FSCP 18/1 time expectation behavior.....	54
9.3.3	Calculation of the worst case safety function response time.....	55
9.4	Duration of demands	55
9.5	Constraints for calculation of system characteristics.....	55
9.5.1	Safety related constraints.....	55
9.5.2	Probabilistic considerations.....	56
9.6	Maintenance.....	57
9.7	Safety manual	57
10	Assessment.....	58
	Annex A (informative) Additional information for functional safety communication profiles of CPF 18.....	59
	Annex B (informative) Information for assessment of the functional safety communication profiles of CPF 18.....	60
	Bibliography	61
	Figure 1 – Relationships of IEC 61784-3 with other standards (machinery).....	7
	Figure 2 – Relationships of IEC 61784-3 with other standards (process)	8
	Figure 3 – FSCP 18/1 system.....	19
	Figure 4 – FSCP 18/1 software architecture	21
	Figure 5 – SPDO interaction model	23
	Figure 6 – SHB interaction model.....	24
	Figure 7 – Safety process data object structure	25
	Figure 8 – Safety heartbeat request structure	26
	Figure 9 – Safety heartbeat response structure	27
	Figure 10 – Safety PDU for FSCP 18/1 embedded in a Type 22 CDC data section	29
	Figure 11 – SALMT state machine.....	30
	Figure 12 – RxSPDO state machine	32
	Figure 13 – Heartbeat procedure.....	34
	Figure 14 – Delay measurement principle.....	34
	Figure 15 – Parameter handling	35
	Figure 16 – Safety response time components	54
	Figure 17 – Considered data fields for message size calculation.....	56
	Figure 18 – Residual error rate.....	57

Table 1 – Object definition	18
Table 2 – Safety PDU element definition	18
Table 3 – Communication errors and detection measures	21
Table 4 – SPDO PDU structure	25
Table 5 – SHB request PDU structure	27
Table 6 – SHB response PDU structure	28
Table 7 – SHB safety communication layer state encoding	28
Table 8 – SALMT commands	30
Table 9 – System states of SALMT state machine	31
Table 10 – State transitions SALMT state machine	31
Table 11 – System states of RxSPDO state machine	32
Table 12 – State transitions RxSPDO state machine	33
Table 13 – Timeouts	33
Table 14 – Safety object dictionary structure	36
Table 15 – Objects of communication section	36
Table 16 – Device type	37
Table 17 – Safety ID	38
Table 18 – Safety consumer heartbeat entry	39
Table 19 – Safety consumer heartbeat	40
Table 20 – Safety producer heartbeat parameter	41
Table 21 – Safety bus cycle times	44
Table 22 – SPDO timeout tolerance	45
Table 23 – Receive SPDO communication parameter	45
Table 24 – Transmit SPDO communication parameter	48
Table 25 – Mapping format	51
Table 26 – Receive SPDO mapping parameter	51
Table 27 – Transmit SPDO mapping parameter	52
Table 28 – Indicator states definiton	53
Table 29 – STATUS indicator states	53

INTERNATIONAL ELECTROTECHNICAL COMMISSION

**INDUSTRIAL COMMUNICATION NETWORKS –
PROFILES**

**Part 3-18: Functional safety fieldbuses –
Additional specifications for CPF 18**

FOREWORD

- 1) The International Electrotechnical Commission (IEC) is a worldwide organization for standardization comprising all national electrotechnical committees (IEC National Committees). The object of IEC is to promote international co-operation on all questions concerning standardization in the electrical and electronic fields. To this end and in addition to other activities, IEC publishes International Standards, Technical Specifications, Technical Reports, Publicly Available Specifications (PAS) and Guides (hereafter referred to as "IEC Publication(s)"). Their preparation is entrusted to technical committees; any IEC National Committee interested in the subject dealt with may participate in this preparatory work. International, governmental and non-governmental organizations liaising with the IEC also participate in this preparation. IEC collaborates closely with the International Organization for Standardization (ISO) in accordance with conditions determined by agreement between the two organizations.
- 2) The formal decisions or agreements of IEC on technical matters express, as nearly as possible, an international consensus of opinion on the relevant subjects since each technical committee has representation from all interested IEC National Committees.
- 3) IEC Publications have the form of recommendations for international use and are accepted by IEC National Committees in that sense. While all reasonable efforts are made to ensure that the technical content of IEC Publications is accurate, IEC cannot be held responsible for the way in which they are used or for any misinterpretation by any end user.
- 4) In order to promote international uniformity, IEC National Committees undertake to apply IEC Publications transparently to the maximum extent possible in their national and regional publications. Any divergence between any IEC Publication and the corresponding national or regional publication shall be clearly indicated in the latter.
- 5) IEC itself does not provide any attestation of conformity. Independent certification bodies provide conformity assessment services and, in some areas, access to IEC marks of conformity. IEC is not responsible for any services carried out by independent certification bodies.
- 6) All users should ensure that they have the latest edition of this publication.
- 7) No liability shall attach to IEC or its directors, employees, servants or agents including individual experts and members of its technical committees and IEC National Committees for any personal injury, property damage or other damage of any nature whatsoever, whether direct or indirect, or for costs (including legal fees) and expenses arising out of the publication, use of, or reliance upon, this IEC Publication or any other IEC Publications.
- 8) Attention is drawn to the Normative references cited in this publication. Use of the referenced publications is indispensable for the correct application of this publication.

This consolidated version of the official IEC Standard and its amendment has been prepared for user convenience.

IEC 61784-3-18 edition 1.1 contains the first edition (2011-04) [documents 65C/639/FDIS and 65C/649/RVD] and its amendment 1 (2016-07) [documents 65C/851/FDIS and 65C/854/RVD].

In this Redline version, a vertical line in the margin shows where the technical content is modified by amendment 1. Additions are in green text, deletions are in strikethrough red text. A separate Final version with all changes accepted is available in this publication.

International Standard IEC 61784-3-18 has been prepared by subcommittee 65C: Industrial networks, of IEC technical committee 65: Industrial process measurement, control and automation.

This publication has been drafted in accordance with the ISO/IEC Directives, Part 2.

A list of all parts of the IEC 61784-3 series, published under the general title *Industrial communication networks – Profiles – Functional safety fieldbuses*, can be found on the IEC website.

The committee has decided that the contents of the base publication and its amendment will remain unchanged until the stability date indicated on the IEC web site under "http://webstore.iec.ch" in the data related to the specific publication. At this date, the publication will be

- reconfirmed,
- withdrawn,
- replaced by a revised edition, or
- amended.

IMPORTANT – The 'colour inside' logo on the cover page of this publication indicates that it contains colours which are considered to be useful for the correct understanding of its contents. Users should therefore print this document using a colour printer.

(<https://standards.iteh.ai>)
Document Preview

IEC 61784-3-18:2011

<https://standards.iteh.ai/standards/iec/ac3352fb-bd87-40f1-9671-7953c42fe5c2/iec-61784-3-18-2011>

0 Introduction

0.1 General

The IEC 61158 fieldbus standard together with its companion standards IEC 61784-1 and IEC 61784-2 defines a set of communication protocols that enable distributed control of automation applications. Fieldbus technology is now considered well accepted and well proven. Thus many fieldbus enhancements are emerging, addressing not yet standardized areas such as real time, safety-related and security-related applications.

This standard explains the relevant principles for functional safety communications with reference to IEC 61508 series and specifies several safety communication layers (profiles and corresponding protocols) based on the communication profiles and protocol layers of IEC 61784-1, IEC 61784-2 and the IEC 61158 series. It does not cover electrical safety and intrinsic safety aspects.

Figure 1 shows the relationships between this standard and relevant safety and fieldbus standards in a machinery environment.

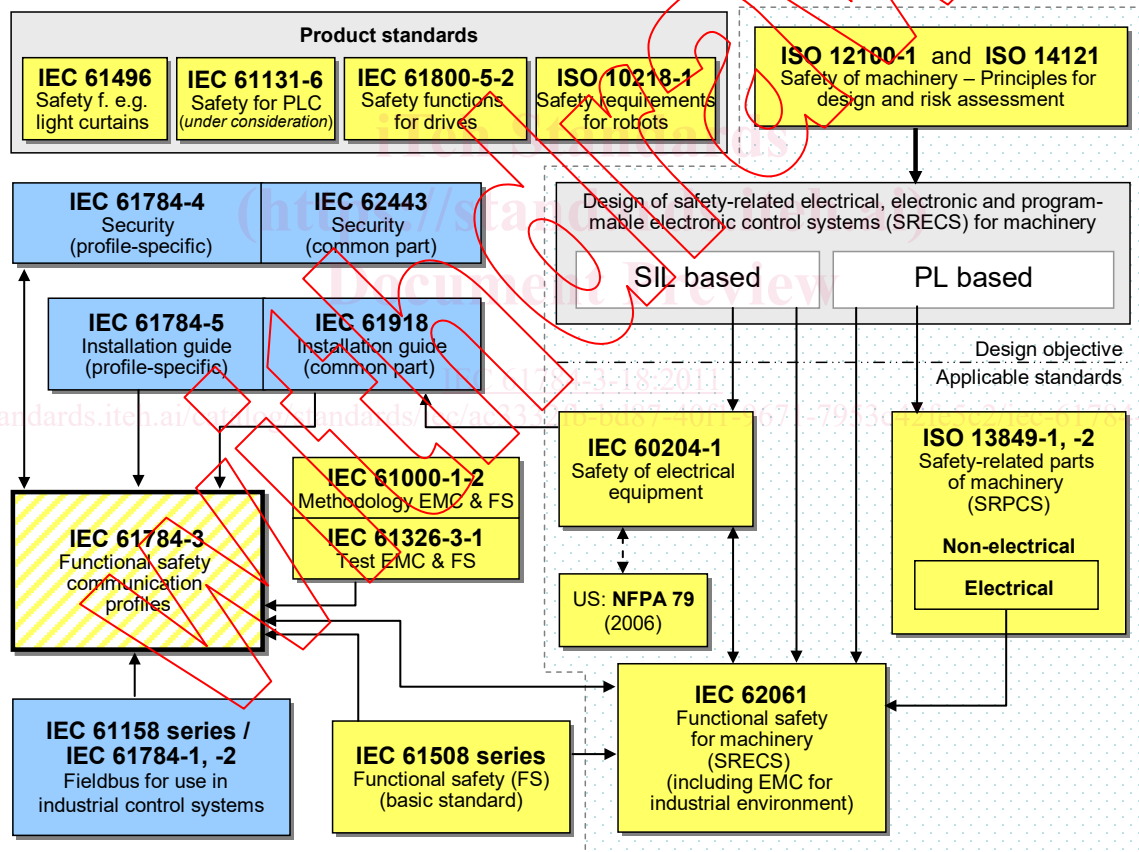

- Key**
- (yellow) safety-related standards
 - (blue) fieldbus-related standards
 - (dashed yellow) this standard

IEC 768/11

NOTE Subclauses 6.7.6.4 (high complexity) and 6.7.8.1.6 (low complexity) of IEC 62061 specify the relationship between PL (Category) and SIL.

Figure 1 – Relationships of IEC 61784-3 with other standards (machinery)

Figure 2 shows the relationships between this standard and relevant safety and fieldbus standards in a process environment.

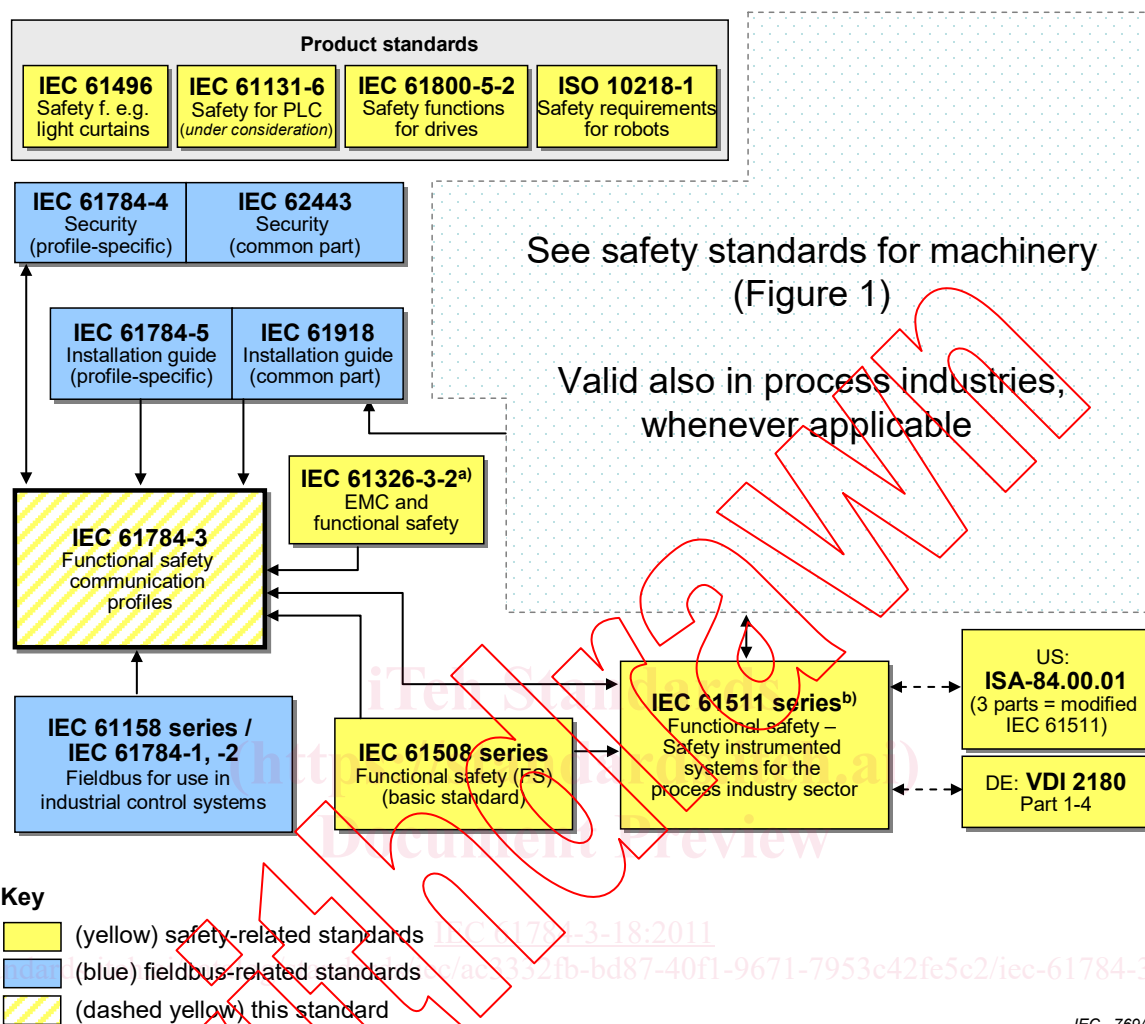

^a For specified electromagnetic environments; otherwise IEC 61326-3-1.

^b EN ratified.

Figure 2 – Relationships of IEC 61784-3 with other standards (process)

Safety communication layers which are implemented as parts of safety-related systems according to IEC 61508 series provide the necessary confidence in the transportation of messages (information) between two or more participants on a fieldbus in a safety-related system, or sufficient confidence of safe behaviour in the event of fieldbus errors or failures.

Safety communication layers specified in this standard do this in such a way that a fieldbus can be used for applications requiring functional safety up to the Safety Integrity Level (SIL) specified by its corresponding functional safety communication profile.

The resulting SIL claim of a system depends on the implementation of the selected functional safety communication profile within this system – implementation of a functional safety communication profile in a standard device is not sufficient to qualify it as a safety device.

This standard describes:

- basic principles for implementing the requirements of IEC 61508 series for safety-related data communications, including possible transmission faults, remedial measures and considerations affecting data integrity;
- individual description of functional safety profiles for several communication profile families in IEC 61784-1 and IEC 61784-2;
- safety layer extensions to the communication service and protocols sections of the IEC 61158 series.

0.2 Patent declaration

The International Electrotechnical Commission (IEC) draws attention to the fact that it is claimed that compliance with this document may involve the use of a patent concerning the functional safety communication profiles for family 18 as follows, where the [xx] notation indicates the holder of the patent right:

DE 10 2008 007 672.4-31 [PI] Verfahren und Vorrichtung zum Übertragen von Daten in einem Netzwerk

IEC takes no position concerning the evidence, validity and scope of this patent right.

The holder of this patent right has assured the IEC that he/she is willing to negotiate licences either free of charge or under reasonable and non-discriminatory terms and conditions with applicants throughout the world. In this respect, the statement of the holder of this patent right is registered with IEC. Information may be obtained from:

Information may be obtained from:

[PI] Pilz GmbH & Co. KG
Felix-Wankel-Str. 2
73760 Ostfildern
GERMANY

Attention is drawn to the possibility that some of the elements of this document may be the subject of patent rights other than those identified above. IEC shall not be held responsible for identifying any or all such patent rights.

ISO (www.iso.org/patents) and IEC (http://www.iec.ch/tctools/patent_decl.htm) maintain on-line data bases of patents relevant to their standards. Users are encouraged to consult the data bases for the most up to date information concerning patents.

INDUSTRIAL COMMUNICATION NETWORKS – PROFILES

Part 3-18: Functional safety fieldbuses – Additional specifications for CPF 18

1 Scope

This part of the IEC 61784-3 series specifies a safety communication layer (services and protocol) based on CPF 18 of IEC 61784-2 and IEC 61158 Type 22. It identifies the principles for functional safety communications defined in IEC 61784-3 that are relevant for this safety communication layer.

NOTE 1 It does not cover electrical safety and intrinsic safety aspects. Electrical safety relates to hazards such as electrical shock. Intrinsic safety relates to hazards associated with potentially explosive atmospheres.

This part¹ defines mechanisms for the transmission of safety-relevant messages among participants within a distributed network using fieldbus technology in accordance with the requirements of IEC 61508 series² for functional safety. These mechanisms may be used in various industrial applications such as process control, manufacturing automation and machinery.

This part provides guidelines for both developers and assessors of compliant devices and systems.

NOTE 2 The resulting SIL claim of a system depends on the implementation of the selected functional safety communication profile within this system – implementation of a functional safety communication profile according to this part in a standard device is not sufficient to qualify it as a safety device.

2 Normative references

The following referenced documents are indispensable for the application of this document. For dated references, only the edition cited applies. For undated references, the latest edition of the referenced document (including any amendments) applies.

IEC 61158-3-22, *Industrial communication networks – Fieldbus specifications – Part 3-22: Data-link layer service definition – Type 22 elements*

IEC 61158-4-22, *Industrial communication networks – Fieldbus specifications – Part 4-22: Data-link layer protocol specification – Type 22 elements*

IEC 61158-5-22, *Industrial communication networks – Fieldbus specifications – Part 5-22: Application layer service definition – Type 22 elements*

IEC 61158-6-22, *Industrial communication networks – Fieldbus specifications – Part 6-22: Application layer protocol specification – Type 22 elements*

IEC 61508 (all parts), *Functional safety of electrical/electronic/programmable electronic safety-related systems*

¹ In the following pages of this standard, “this part” will be used for “this part of the IEC 61784-3 series”.

² In the following pages of this standard, “IEC 61508” will be used for “IEC 61508 series”.