



SLOVENSKI STANDARD

SIST ISO 10753:1998

01-november-1998

CVfUhnUdf]dfUj c`dfYa c[U!`CWbUbu[b^Ybcgh]fUn `Ya VY`d`Ugh]dfYa c[Uj `gdc`f
n`j cXbc`na Yg`c

Coal preparation plant -- Assessment of the liability to breakdown in water of materials associated with coal seams

iTeh STANDARD PREVIEW

Ateliers de préparation du charbon -- Évaluation de la fiabilité de la fragmentation dans l'eau de matériaux associés aux gisements de charbon

[SIST ISO 10753:1998](https://standards.iteh.ai/catalog/standards/sist/0e095f53-2fd4-4c19-a419-0ac5b19bc747/sist-iso-10753-1998)

Ta slovenski standard je istoveten z: **ISO 10753:1994**

ICS:

73.120 Oprema za predelavo rudnin Equipment for processing of minerals

SIST ISO 10753:1998

en

iTeh STANDARD PREVIEW
(standards.iteh.ai)

SIST ISO 10753:1998

<https://standards.iteh.ai/catalog/standards/sist/0e095f53-2fd4-4c19-a419-6ae5b19be747/sist-iso-10753-1998>

INTERNATIONAL
STANDARD

ISO
10753

First edition
1994-02-01

**Coal preparation plant — Assessment of
the liability to breakdown in water of
materials associated with coal seams**

iTeh STANDARD PREVIEW

(standards.iteh.ai)

*Ateliers de préparation du charbon — Évaluation de la fiabilité de la
fragmentation dans l'eau de matériaux associés aux gisements de charbon*

SIST ISO 10753:1998

<https://standards.iteh.ai/catalog/standards/sist/0e095f53-2fd4-4c19-a419-6ae5b19be747/sist-iso-10753-1998>



Reference number
ISO 10753:1994(E)

ISO 10753:1994(E)**Foreword**

ISO (the International Organization for Standardization) is a worldwide federation of national standards bodies (ISO member bodies). The work of preparing International Standards is normally carried out through ISO technical committees. Each member body interested in a subject for which a technical committee has been established has the right to be represented on that committee. International organizations, governmental and non-governmental, in liaison with ISO, also take part in the work. ISO collaborates closely with the International Electrotechnical Commission (IEC) on all matters of electrotechnical standardization.

Draft International Standards adopted by the technical committees are circulated to the member bodies for voting. Publication as an International Standard requires approval by at least 75 % of the member bodies casting a vote.

International Standard ISO 10753 was prepared by Technical Committee ISO/TC 27, *Solid mineral fuels*, Subcommittee SC 1, *Coal preparation. Terminology and performance*.

<https://standards.iteh.ai/catalog/standards/sist/0e095f53-2fd4-4c19-a419->

Annex A forms an integral part of this International Standard. Annex B is for information only.

© ISO 1994

All rights reserved. Unless otherwise specified, no part of this publication may be reproduced or utilized in any form or by any means, electronic or mechanical, including photocopying and microfilm, without permission in writing from the publisher.

International Organization for Standardization
Case Postale 56 • CH-1211 Genève 20 • Switzerland

Printed in Switzerland

Introduction

In this International Standard, the materials associated with coal seams are collectively referred to as "shale", although they may contain a variety of rocks and minerals. This International Standard describes a method of assessing the liability of these materials to breakdown on agitation with water. Future activity on this subject could involve a method for simulating the breakdown that is likely to occur, in practice, in different types of coal preparation plants, to generate samples for further testing.

The liability of the shale to breakdown is measured by the proportion of the degraded material passing through a test sieve having a nominal size of openings of 500 μm .

The method described in this International Standard also enables the liability of the shale to form slimes to be assessed, by determining the proportion that is below a nominal particle size of 10 μm , using a simplified sedimentation technique. This technique is based on the assumption that, in the size range being examined, all the particles are spherical, have a relative density of 2,5, and fall freely through the suspending liquid according to Stokes's Law. These conditions are not entirely fulfilled in practice and the particle size is, therefore, referred to as a nominal value. The extent of breakdown, as measured by this method, will be affected by whether the shale exhibits any self-flocculation. In the described test, distilled water (or the equivalent) is used to avoid possible flocculation of the shale by any soluble salts in the water. The test may be adapted to assess the relative tendencies of shales to break down in a particular plant, by using the same water as is used in that plant. However, it is emphasized that the results of such tests, using plant water, have to be treated with caution because the extent of breakdown that will occur in practice is influenced by the interaction of all the components present during the washing process, including, for example, any accumulation of soluble salts in the circuit, and by other factors, such as the residence time in the plant.

The relationship between the proportion of degraded material passing a 500 μm test sieve and the proportion of slimes provides useful information on the character of the breakdown, and is therefore included in the results that are reported.

The amount of breakdown occurring in practice and in the test will be affected by the history of the sample. For this reason, the sample is placed in a sealed container as soon as is practicable after being taken.

iTeh STANDARD PREVIEW

This page intentionally left blank
(standards.iteh.ai)

SIST ISO 10753:1998

<https://standards.iteh.ai/catalog/standards/sist/0e095f53-2fd4-4c19-a419-6ae5b19be747/sist-iso-10753-1998>

Coal preparation plant — Assessment of the liability to breakdown in water of materials associated with coal seams

1 Scope

This International Standard specifies a method for assessing the liability of materials associated with coal seams to breakdown on agitation with water.

2 Normative reference

The following standard contains provisions which, through reference in this text, constitute provisions of this International Standard. At the time of publication, the edition indicated was valid. All standards are subject to revision, and parties to agreements based on this International Standard are encouraged to investigate the possibility of applying the most recent edition of the standard indicated below. Members of IEC and ISO maintain registers of currently valid International Standards.

ISO 3310-1:1990, *Test sieves — Technical requirements and testing — Part 1: Test sieves of metal wire cloth*.

3 Principle

Degradation of a test portion of shale in the size range 5,6 mm to 2,8 mm, by controlled agitation in water. Determination of the proportion of degraded material passing through a 500 μm sieve, and determination of the proportion of degraded material of nominal top size less than 10 μm by sedimentation.

4 Reagent

During the test, use only distilled water or water of equivalent purity.

5 Apparatus

5.1 Rigid cylindrical jar, of non-corrodible material and of capacity 1,0 litre \pm 0,1 litre, with an internal height of approximately 170 mm (internal diameter approximately 85 mm) and a height/diameter ratio $2,0 \pm 0,1$.

The jar shall have a hard lid which can be secured to form a watertight seal.

5.2 Rotation machine, capable of rotating the jar about a transverse axis at a rotational frequency of $40 \text{ min}^{-1} \pm 1 \text{ min}^{-1}$ (speed of 40 r/min \pm 1 r/min).

A typical assembly is shown in figure 1.

NOTE 1 A suitable drive can be provided by a 0,1 kW single-phase motor running at 1 500 r/min, geared down to 40 r/min.

5.3 Test sieve, having nominal size of openings 500 μm , complying with ISO 3310-1.

NOTE 2 This sieve is liable to suffer minor distortion when heated to 105 °C (see 7.5), and should therefore be reserved exclusively for use in this test. Furthermore, it is important to ensure that the sieve is constructed of materials that are stable at the temperature of drying.

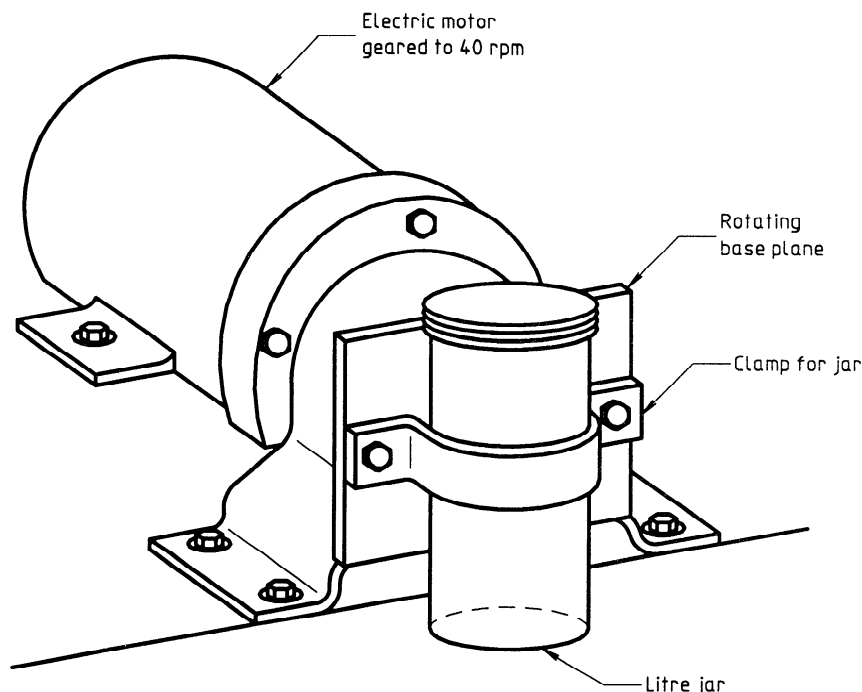

Figure 1 — Typical apparatus for the determination of breakdown characteristics in water

5.4 Funnel, into which the 500 μm test sieve (5.3) will fit.

5.5 Heat-resistant tray, of non-corrodible material, large enough to accommodate the 500 μm test sieve.

5.6 Container, of capacity approximately 100 ml, fitted with a cover.

5.7 Two test sieves, having nominal sizes of openings 5,6 mm and 2,8 mm, complying with ISO 3310-1.

5.8 Two measuring cylinders, of capacity 1 litre each, fitted with stoppers.

5.9 Modified Andreasen sedimentation apparatus, comprising (see figure 2) a measuring cylinder (A), having a pipette (B) connected to a 10 ml reservoir (C) via a three-way stopcock (D). The neck of the flask is fitted with a ground-glass stopper (E) which has a small opening (F) to allow air to enter the flask when a sample is withdrawn, by applying suction at point G; an outlet (H) allows the sample to be run off. The Andreasen sedimentation apparatus is modified by reducing the length of stem of the pipette, so that the sample is withdrawn at the 100 mm mark. The

apparatus shall be protected from all sources of vibration during the test.

5.10 Suction device, capable of applying a steady, controlled suction to the sedimentation pipette (5.9).

NOTE 3 An aspirator is preferred for this purpose.

5.11 Evaporating dish, of nickel or stainless steel, having a diameter of 50 mm.

5.12 Flask, of capacity at least 2 litres.

5.13 Thermostatically-controlled bath, capable of being maintained at approximately ambient temperature, to within $\pm 0,2$ $^{\circ}\text{C}$, and of suitable dimensions to contain the sedimentation apparatus (5.9), a measuring cylinder (5.8) and the flask (5.12).

The bath shall operate without causing significant vibration or disturbance of the measuring cylinder and its contents, when placed in the bath.

NOTE 4 If a thermostatically controlled bath is not available, a large container filled with water that has been allowed to attain room temperature may be used instead.

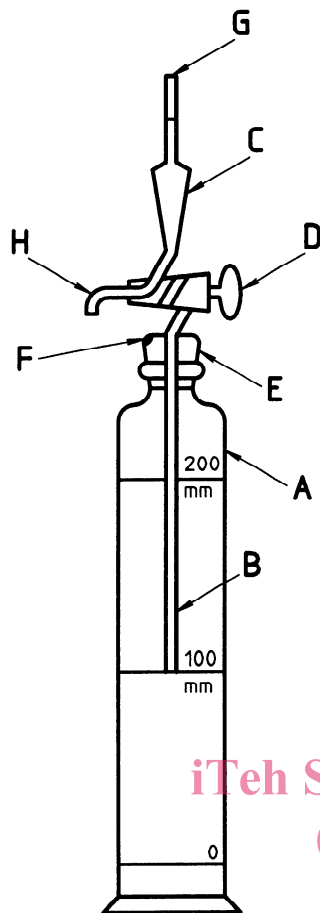
**Key**

- A Graduated cylindrical flask
- B Pipette
- C 10 ml Reservoir
- D Three-way stopcock
- E Ground-glass stopper
- F Small opening in stopper (to allow air to enter)
- G Suction application point
- H Outlet

Figure 2 — Modified Andreasen sedimentation apparatus

5.14 Drying oven, well ventilated and capable of being maintained in the temperature range 105 °C to 110 °C.

5.15 Stop clock.

5.16 Analytical balance(s), capable of weighing up to 20 g to the nearest 0,000 1 g and up to 200 g to the nearest 0,01 g.

5.17 Wash bottle, of capacity at least 400 ml, fitted with a fine spray-jet outlet.

5.18 Desiccator.

5.19 Vibration-free bench.

6 Sampling and preparation of test sample

If sufficient material is available, take a representative sample containing a minimum of 1 kg in the 5,6 mm to 2,8 mm size fraction. If there is insufficient material to provide the required amount in this size fraction, crush all the larger shale and add the 5,6 mm to 2,8 mm size fraction of the crushed product to that size fraction in the original material. If neither of these measures provides sufficient material, a size fraction of 5,6 mm to 1,0 mm shall be used instead. Full details of the sample taken shall be included in the test report (see clause 10).

NOTES

5 It may be useful to prepare and test separate representative samples from the floor, roof and dirt bands for each seam.

<https://standards.iteh.ai/catalog/standards/sist/6ae5b19be747/sist-iso-10753-1998>

6.99 If the test sample is obtained from raw coal by means of float and sink separation, this may affect the results of the test.

Remove the dust from the test sample by gentle blowing with air and store the test sample, until required for testing, in a secure, sealed container.

7 Procedure

7.1 Determination of initial moisture content

Determine the moisture content of the shale "as received" by weighing a 10 g portion, to an accuracy of $\pm 0,000 1$ g, drying in the oven (5.14) for 2 h at 105 °C to 110 °C and then reweighing.

7.2 Preparation of test portion

Dry for 2 h in the oven (5.14), at 105 °C to 110 °C, enough of the test sample to provide a mass of 120 g, when dried, and place it in a sealed container.

7.3 Determination of residual moisture content

Determine the residual moisture in the test portion by taking 10 g of the dried test sample (see 7.2),