

INTERNATIONAL
STANDARD

ISO
10780

First edition
1994-11-15

**Stationary source emissions —
Measurement of velocity and volume
flowrate of gas streams in ducts**

iTeh STANDARD PREVIEW

*Émissions de sources fixes — Mesurage de la vitesse et du débit-volume
des courants gazeux dans des conduites*

[ISO 10780:1994](https://standards.iteh.ai/catalog/standards/sist/22302ecc-092b-4dd9-9c1c-3c6838dd848b/iso-10780-1994)

<https://standards.iteh.ai/catalog/standards/sist/22302ecc-092b-4dd9-9c1c-3c6838dd848b/iso-10780-1994>

INTERNATIONAL

ISO



Reference number
ISO 10780:1994(E)

Contents

	Page
1 Scope	1
2 Normative references	1
3 Definitions and symbols	1
4 Principle	1
5 Apparatus	2
6 Environmental requirements	8
7 Test procedure	9
8 Calculation of velocity and volume flowrate	13
9 Accuracy	15
10 Test report	15

Annexes

A Maintenance of Pitot tubes	16
B Determination of duct static pressure with Pitot tubes	17
C Determination of flow direction with Pitot tubes	18
D Correction of swirling flow	19

iTeh STANDARD PREVIEW

(standards.iteh.ai)

ISO 10780:1994

[https://standards.iteh.ai/catalog/standards/sist/22502ccc-092b-4dd9-9c1c-](https://standards.iteh.ai/catalog/standards/sist/22502ccc-092b-4dd9-9c1c-3c6838dd848b/iso-10780-1994)

[3c6838dd848b/iso-10780-1994](https://standards.iteh.ai/catalog/standards/sist/22502ccc-092b-4dd9-9c1c-3c6838dd848b/iso-10780-1994)

Foreword

ISO (the International Organization for Standardization) is a worldwide federation of national standards bodies (ISO member bodies). The work of preparing International Standards is normally carried out through ISO technical committees. Each member body interested in a subject for which a technical committee has been established has the right to be represented on that committee. International organizations, governmental and non-governmental, in liaison with ISO, also take part in the work. ISO collaborates closely with the International Electrotechnical Commission (IEC) on all matters of electrotechnical standardization.

Draft International Standards adopted by the technical committees are circulated to the member bodies for voting. Publication as an International Standard requires approval by at least 75 % of the member bodies casting a vote.

International Standard ISO 10780 was prepared by Technical Committee ISO/TC 146, *Air quality*, Subcommittee SC 1, *Stationary source emissions*.

<https://standards.iteh.ai/catalog/standards/sist/31013101-91d-4e11-8c83-6d648710-10780-1994>

Annexes A and B form an integral part of this International Standard. Annexes C and D are for information only.

Introduction

ISO/TC 146/SC 1 prepares International Standards for the determination of concentrations of pollutants in stationary source emissions. For the calculation of the emission rate, the volume flow of a gas stream has to be measured. This International Standard specifies methods for the determination of the velocity and the volume flowrate of gas streams in ducts and chimneys. It is based largely on ISO 3966:1977, ISO 4006:1977 and ISO 9096:1990. ISO 3966 and ISO 4006 specify methods for measuring the flow of process streams in closed conduits using type L Pitot static tubes. ISO 9096 specifies ways to measure velocity and mass flow when sampling for particles in gas streams in ducts and chimneys. This International Standard differs from ISO 3966 and ISO 4006 in allowing the use of the type S Pitot tube (a device not mentioned in ISO 3966) as well as the type L. It differs from ISO 9096 in that it provides considerably more information concerning the construction and use of the Pitot tubes commonly used to measure the velocity and volume flowrate of gas streams in ducts and chimneys.

[ISO 10780:1994](https://standards.iteh.ai/catalog/standards/sist/22302ecc-092b-4dd9-9c1c-3c6838dd848b/iso-10780-1994)

<https://standards.iteh.ai/catalog/standards/sist/22302ecc-092b-4dd9-9c1c-3c6838dd848b/iso-10780-1994>

Stationary source emissions — Measurement of velocity and volume flowrate of gas streams in ducts

1 Scope

This International Standard specifies manual methods for determining the velocity and volume flowrate of gas streams in ducts, stacks and chimneys vented to the atmosphere. It specifies the use of two types of Pitot tubes, type L and type S, for determining the velocity and the volume flowrate, and recommends sampling conditions for which each type of Pitot tube is preferred.

The use of other types of Pitot tubes is permitted in accordance with this International Standard providing they meet the accuracy requirements in clause 10.

This International Standard applies to gas streams with essentially constant density, temperature, flowrate and pressure at the sampling points. It applies to situations where the Reynolds number of the gas stream as it flows around the Pitot tube is greater than 1,2, the pressure differential across the Pitot tube orifices (ports) is greater than 5 Pa and the cross-sectional area of the duct at the sampling point is at least 0,07 m². It specifies the technology and maintenance of Pitot tubes, the calculation of local velocities from measured differential pressures and the computation of volume flowrate by velocity integration. This International Standard assumes that the measurements are taken either at the same time that a pollutant sample is being collected or independently of actual sample collection; in the latter case, the purpose of the test might be to select the sampling location for collecting a pollutant sample or to calibrate an automated flow measuring instrument installed in the duct. Thus, this International Standard should be suitable as both a primary measurement (velocity and volume flowrate) and as an ancillary measurement (selection of sampling rate for pollutant sampling, calculation of pollutant emission rate, etc.).

If any of the requirements of this International Standard are not fulfilled, this method may still be applied

in special cases, but the uncertainty in the velocity and volume flowrate may be larger.

2 Normative references

The following standards contain provisions which, through reference in this text, constitute provisions of this International Standard. At the time of publication, the editions indicated were valid. All standards are subject to revision, and parties to agreements based on this International Standard are encouraged to investigate the possibility of applying the most recent editions of the standards indicated below. Members of IEC and ISO maintain registers of currently valid International Standards.

ISO 3966:1977, *Measurement of fluid flow in closed conduits — Velocity area method using Pitot static tubes.*

ISO 9096:1992, *Stationary source emissions — Determination of concentration and mass flow rate of particulate material in gas-carrying ducts — Manual gravimetric method.*

3 Definitions and symbols

For the purposes of this International Standard, the definitions and symbols given in ISO 9096 apply. For the user's convenience, these symbols are defined in this International Standard at the point where they are first used.

4 Principle

The average velocity of the gas stream is determined using a Pitot tube to determine the velocity head, v , at selected points in the cross-section of the duct. The volume flowrate, q_v , is calculated by multiplying the cross-sectional area by the average velocity of the gas stream at that cross-section.

The method consists of:

- a) determining the dimensions, D , of the duct at the sampling location;
- b) determining the number, n , and location, x , of the measuring points in the cross-section needed to adequately determine the velocity profile;
- c) measuring the pressure differential, Δp , across the Pitot tube pressure ports when the Pitot tube is placed at these sampling points;
- d) determining the velocity at each sampling point from given formulae on the basis of these differential pressure measurements; and
- e) calculating the volume flowrate from the product of the average velocity and the cross-sectional area.

5 Apparatus

5.1 Design of the Pitot tube

The type L Pitot tube described in ISO 3966 is preferred when the velocity measurement is made before and after the pollutant sample is collected. This Pitot tube is less sensitive to flow misalignment errors than type S. However, its pressure sensing ports can become plugged in certain sampling conditions. Its use could be difficult in high concentrations of particulate matter or aerosols. In addition, its insertion into thick-walled ducts or smokestacks requires large openings. If the type L Pitot tube and the sampling nozzle are too close to one another, they will adversely influence each other's performance.

The type S Pitot tube can be used when the pollutant sample is collected at the same time the velocity is measured. It is also preferred if the porthole is small, the stack wall is thick, the stack gas is dusty and the stack gas contains aerosols such as water droplets and H_2SO_4 . The type S Pitot tube is considerably more sensitive to alignment error than the type L Pitot tube, but it is less sensitive to interference by a sampling probe nozzle when the distance between the sides of the Pitot tube and the nozzle is at least 1,9 cm. The Pitot tube can be designed to reduce its sensitivity to alignment error.

5.1.1 Type L Pitot tube

This Pitot tube is sometimes termed the standard Pitot static tube or the Prandtl Pitot tube. Its design specifications are described in detail in annex A of ISO 3966:1977. Figure 1 shows an example of a type

L Pitot tube. Type L Pitot tubes meeting the design specifications in ISO 3966 also meet all the requirements of this International Standard. (Before it is used, however, the Pitot tube must be checked to ensure that it meets the design specifications of this International Standard.)

Type L Pitot tubes of other dimensions may also meet the requirements of this International Standard if they are calibrated against a standard Pitot static tube and used as described in this International Standard. The ISO 3966 type L Pitot tube consists of a cylindrical head attached perpendicularly to a stem. It has a calibration factor K of $0,99 \pm 0,01$.

At one or two cross-sections along the head, static-pressure holes are drilled around the circumference, so that the registered pressure is transferred through the head and stem to a point outside the duct.

A small tube, concentric with the head and stem, transfers the total pressure, registered by an orifice facing the flow direction (at the tip of an axially symmetrical nose integral with the head) to a point outside the duct. An alignment arm, fitted to the end of the stem, facilitates alignment of the head when this is obscured by the duct wall.

The nose (including the total pressure orifice) shall be designed to comply with the following requirements.

- a) The response of the differential pressure to inclination of the head relative to the flow shall meet one of the following two conditions (in both cases it is necessary to know the response curve of the Pitot tube):
 - 1) if precise alignment of the Pitot tube with the stack axis is not possible but there is no swirl, the differential pressure should be as independent as possible of the yaw of the head in uniform flow;
 - 2) if precise alignment of the Pitot tube with the conduit axis is possible but swirl is present, the variation of the differential pressure recorded by the tube in uniform flow with yaw angle ρ shall be approximately proportional to $\cos^2 \rho$. If the head is perfectly aligned axially and if swirl is less than $\pm 3^\circ$, the differential pressure shall not deviate from this requirement by more than 1 %.

NOTE 1 Misalignment and swirl can occur simultaneously and efforts should be made to minimize both.

- b) The calibration factors for different specimens of tubes to a particular specification shall be identi-

cal, to within $\pm 1,0 \%$, and shall remain so for the working life of any such tube. If the user has any doubt, an individual calibration of each Pitot tube should be made.

c) The static-pressure holes shall be:

- 1) not larger than 1,6 mm in diameter;
- 2) at least six, and sufficient in number for the damping in the static-pressure circuit to equal that in the total-pressure circuit; on Pitot tubes of small diameter, the orifices may be placed in two planes;
- 3) free of burrs and uniform in diameter;
- 4) placed not less than six head-diameters from the tip of the nose;

5) placed not less than eight head-diameters from the axis of the stem.

5.1.2 Type S Pitot tube

The type S Pitot tube is widely used in stack testing because it is suitable for determining the velocity at the point where the sample is being taken and because it is rugged, small and easy to construct. The construction specifications of this Pitot tube are shown in figure 2. This Pitot tube is normally made of metal tubing with an external diameter of 4 mm to 10 mm. The distance between the base of each leg of the Pitot tube and its face-opening (orifice) plane (dimensions L_1 and L_2 in figure 2) shall be equal for each leg. This distance shall be not less than 1,05 and not more than 10,0 times the external diameter of the tubing.

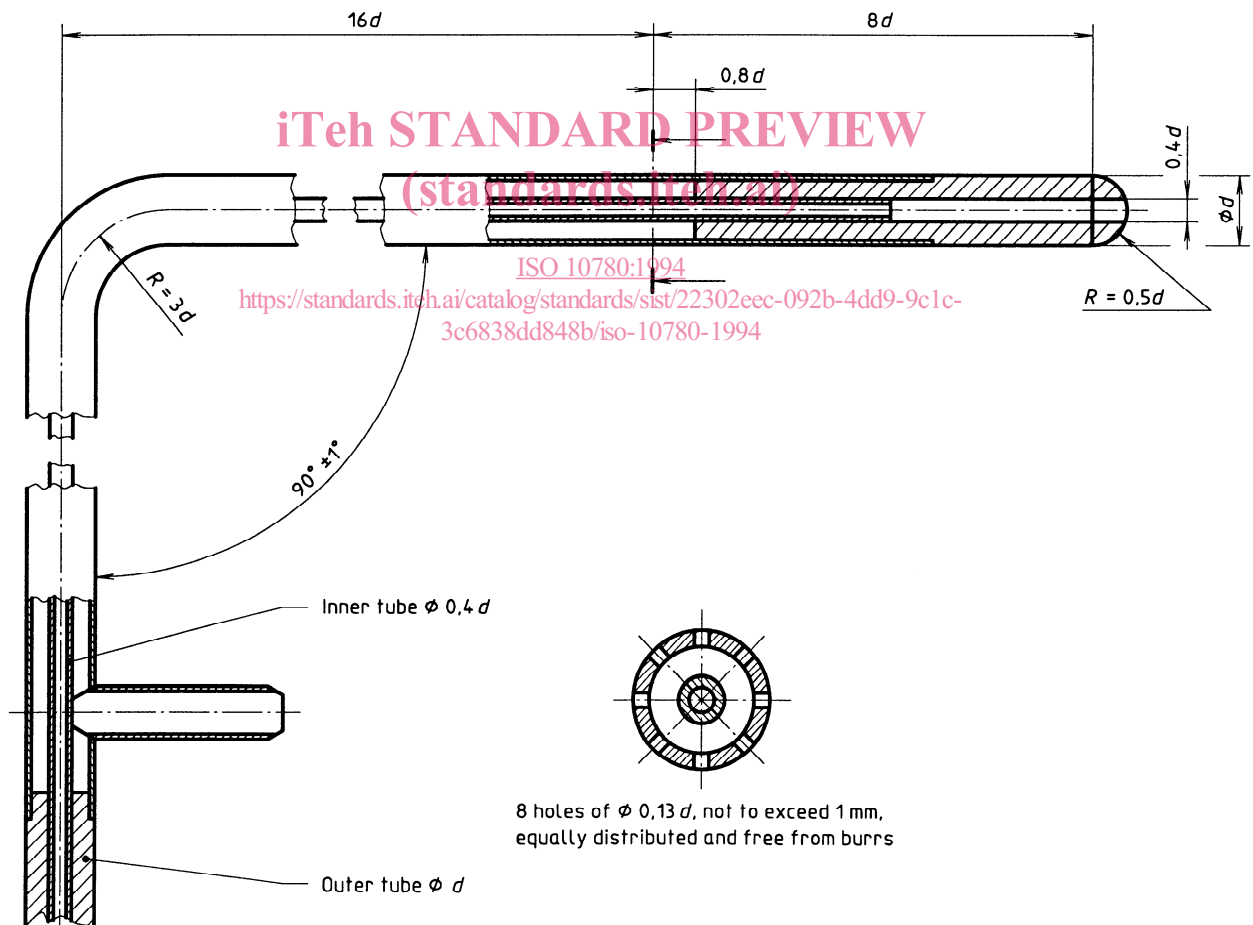

Figure 1 — Example of a type L Pitot tube

If this Pitot tube is to be used without a pollutant sampling probe attached to it, it should be calibrated with a type L Pitot tube to establish its calibration factor. However, if the specifications in figure 2 are met, a calibration factor K of $0,84 \pm 0,01$ may be assumed.

If it is used with a sampling probe attached, and the spacing between the Pitot tube, thermocouple and sampling nozzle conforms to that shown in figures 3 and 4, a calibration factor K of 0,84 may also be assumed. If these spacings are not met, the Pitot tube/sampling probe combination must be calibrated with a type L Pitot tube, as described in 5.2.

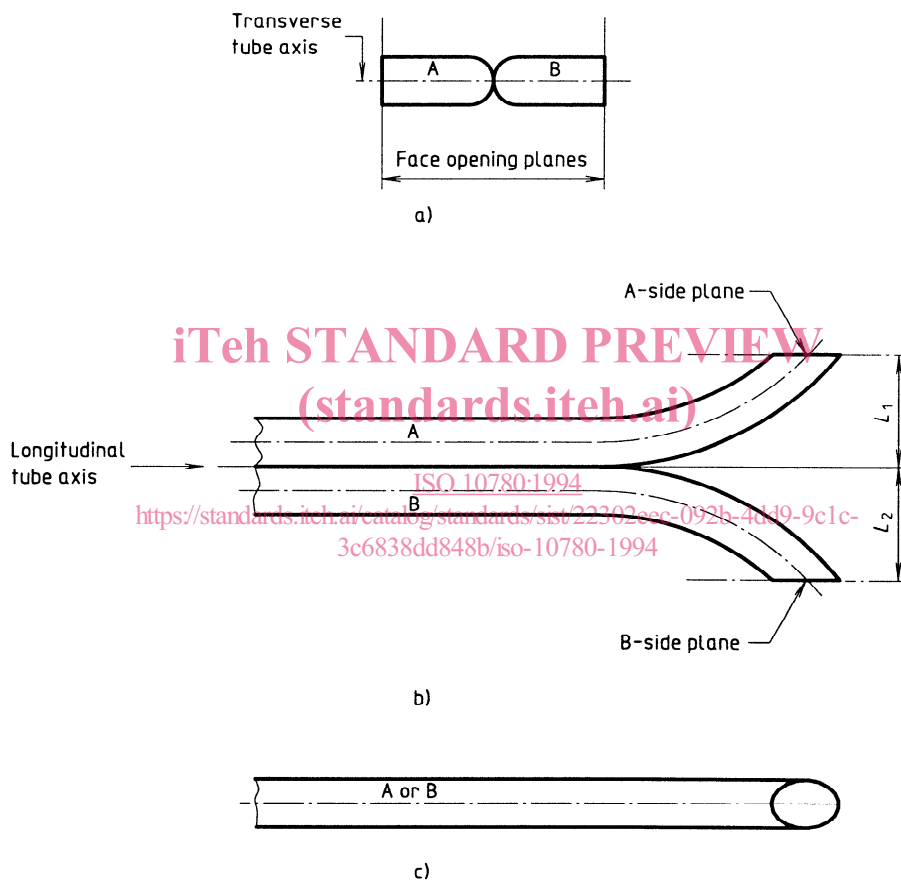
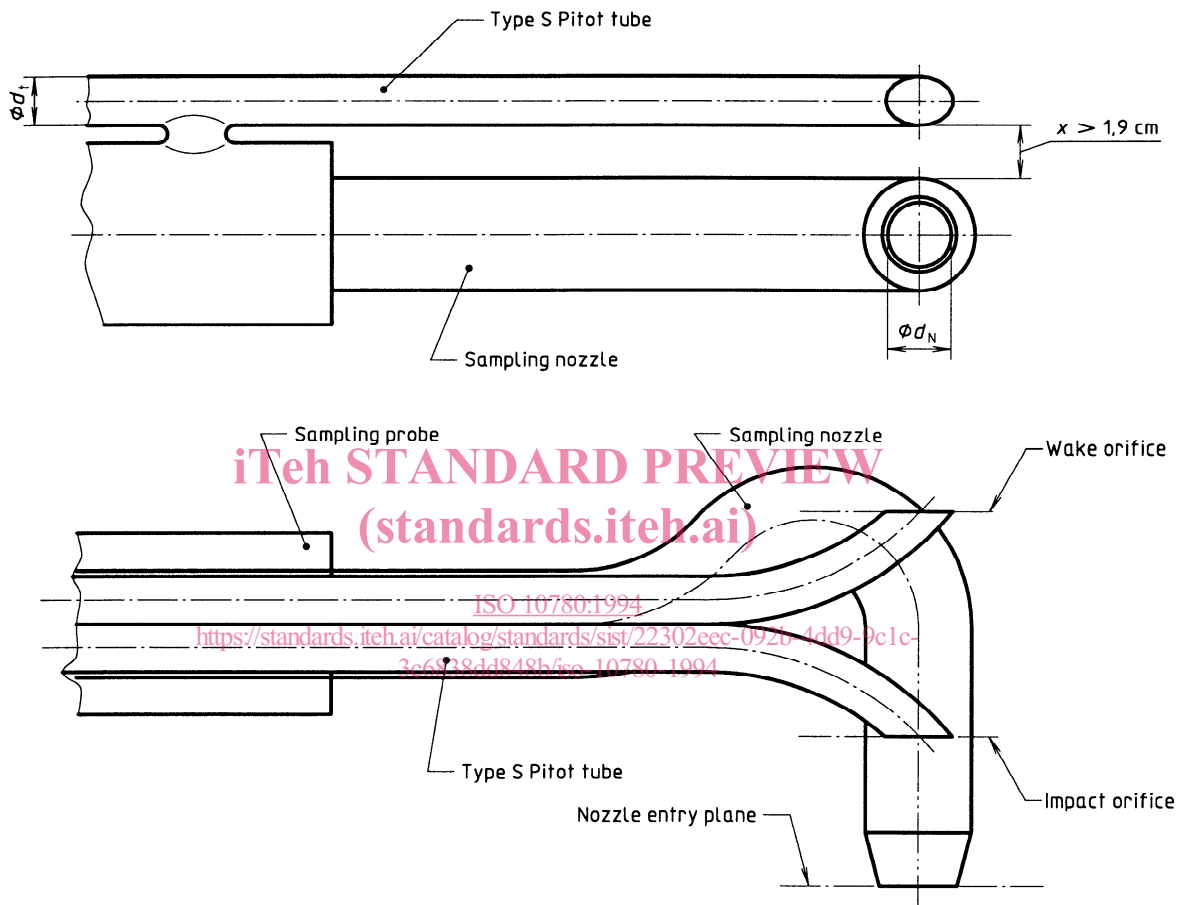

Figure 2 — Properly constructed type S Pitot tube



d_N = sampling nozzle diameter

d_t = type S Pitot tube diameter

Figure 3 — Type S Pitot tube: sampling nozzle spacing required to prevent flow measurement error when d_N equals 1,3 cm

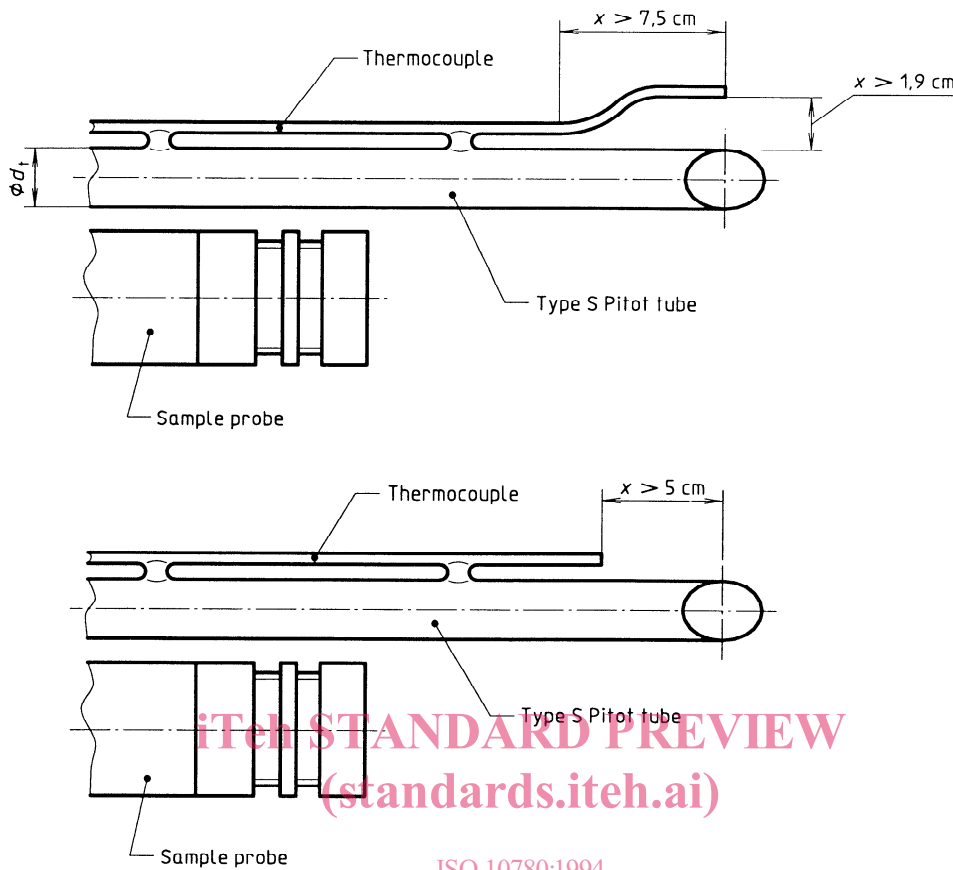

STANDARD PREVIEW
(standards.iteh.ai)

ISO 10780:1994

<https://standards.iteh.ai/catalog/standards/sist/22302ecc-092b-4dd9-9c1c-3e8588489101/iso-10780-1994>

Figure 4 — Type S Pitot tube: thermocouple spacing required to prevent flow measurement error

5.2 Calibration of the Pitot tube

Type L Pitot tubes that do not meet the design specifications of this International Standard shall be calibrated with a Pitot tube which is in accordance with ISO 3966.

5.2.1 Characteristics of the calibration flow system

The flow system shall have the capacity to generate a velocity in the test section of between 11 m/s and 18 m/s. This velocity shall not vary by more than 1,0 % with time to ensure steady flow during the calibration of the Pitot tube. Pitot tubes and Pitot tube/sampling probe assemblies calibrated in this velocity range should be accurate within 3 % for velocities between 5 m/s and 50 m/s. If the Pitot tube or Pitot tube/sampling probe assembly is used to measure velocities below 5 m/s or above 50 m/s, the Pitot tube shall also be calibrated at these other velocities.

The projected area (blockage) of the Pitot tube or Pitot tube/sampling probe assembly shall not exceed 3 % of the cross-sectional area of the test section in the plane in which the calibration is being done.

5.2.2 Calibration procedure

A previously certified or calibrated type L Pitot tube shall be used as the reference standard. The Pitot tube shall be calibrated as follows.

- a) Ensure that the pressure-sensing device is properly zeroed, levelled, etc. and that the tubing connecting the Pitot tube to the pressure-sensing device is leaktight. Turn on the fan and allow the velocity in the test section to stabilize.
- b) Insert the type L Pitot tube into the test section, so that it is at least 8 cm from any interior wall.

Seal the porthole so that air does not leak out from the test section and measure the pressure difference (Δp_{ref}), in pascals (Pa) or equivalent units. Record this value (run 1) using the data form in figure 5 or its equivalent.

- c) Remove the type L Pitot tube and insert the Pitot tube to be calibrated into the test section at the same location as the reference Pitot tube. Seal the porthole as before and repeat the procedure in step b). Record the pressure difference (Δp_{unk} in figure 5 run 1).
- d) Repeat steps b) and c) until three pairs of Δp readings are obtained.

- e) Calculate K for each pair of Δp readings using equation (1) and determine the average K for the Pitot tube being calibrated. If any individual K differs from the average K by more than 0,02, the calibration must be repeated or the Pitot tube must be replaced.

$$K_{unk} = K_{ref} \sqrt{\frac{\Delta p_{ref}}{\Delta p_{unk}}} \dots (1)$$

When calibrating a type S Pitot tube, compare the calibration factors determined with first one leg and then the other leg pointing downstream. Use this Pitot tube only if the two factors differ by no more than 0,01.

Date	
Pitot tube	
Calibrated by	
Type of Pitot tube	
Δp in units of	

	Run	Δp_{ref}	Δp_{unk}	K_{ref}	K_{unk}
Part A	1				
	2				
	3				
Part B ¹⁾	4				
	5				
	6				
NOTE — ref = reference; unk = unknown.					
1) Part B is used for type S Pitot tubes when both legs of the Pitot are calibrated.					

Figure 5 — Pitot tube calibration form