

INTERNATIONAL STANDARD

ISO
10920

First edition
1997-03-15

Gas cylinders — 25E taper thread for connection of valves to gas cylinders — Specification

iTeh STANDARD PREVIEW

(standards.iteh.ai)

*Bouteilles à gaz — Filetages coniques 25E pour le raccordement des
robinets sur les bouteilles à gaz — Spécifications*

ISO 10920:1997

<https://standards.iteh.ai/catalog/standards/sist/599a44e8-1e86-4b0b-98d8-77cc292489bf/iso-10920-1997>



Reference number
ISO 10920:1997(E)

Foreword

ISO (the International Organization for Standardization) is a worldwide federation of national standards bodies (ISO member bodies). The work of preparing International Standards is normally carried out through ISO technical committees. Each member body interested in a subject for which a technical committee has been established has the right to be represented on that committee. International organizations, governmental and non-governmental, in liaison with ISO, also take part in the work. ISO collaborates closely with the International Electrotechnical Commission (IEC) on all matters of electrotechnical standardization.

Draft International Standards adopted by the technical committees are circulated to the member bodies for voting. Publication as an International Standard requires approval by at least 75 % of the member bodies casting a vote.

International Standard ISO 10920 was prepared by Technical Committee ISO/TC 58, *Gas cylinder*, Subcommittee SC 2, *Cylinder fittings*.

TECH STANDARD PREVIEW
(standards.iteh.ai)
ISO 10920:1997
<https://standards.iteh.ai/catalog/standards/sist/599a44e8-1e86-4b0b-98d8-77cc292489bf/iso-10920-1997>

© ISO 1997

All rights reserved. Unless otherwise specified, no part of this publication may be reproduced or utilized in any form or by any means, electronic or mechanical, including photocopying and microfilm, without permission in writing from the publisher.

International Organization for Standardization
Case postale 56 • CH-1211 Genève 20 • Switzerland
Internet central@iso.ch
X.400 c=ch; a=400net; p=iso; o=isocs; s=central

Printed in Switzerland

Introduction

This International Standard belongs to a series of standards specifying thread dimensions and gauge requirements.

Cylinders intended to contain compressed, liquefied or dissolved gas under pressure are fitted with accessories (valves, straight or angle fittings) to allow release of and refilling with, gas. Hereinafter, the term "valve" will apply to such accessories.

The connection between cylinder and valve is obtained by assembly of two taper threads, an external one on the valve stem and an internal one in the cylinder neck, both having the same nominal taper, pitch and thread profile.

iTeh STANDARD PREVIEW (standards.iteh.ai)

[ISO 10920:1997](https://standards.iteh.ai/catalog/standards/sist/599a44e8-1e86-4b0b-98d8-77cc292489bf/iso-10920-1997)

<https://standards.iteh.ai/catalog/standards/sist/599a44e8-1e86-4b0b-98d8-77cc292489bf/iso-10920-1997>

iTeh STANDARD PREVIEW
This page intentionally left blank
(standards.iteh.ai)

ISO 10920:1997

<https://standards.iteh.ai/catalog/standards/sist/599a44e8-1e86-4b0b-98d8-77cc292489bf/iso-10920-1997>

Gas cylinders — 25E taper thread for connection of valves to gas cylinders — Specification

1 Scope

This International Standard specifies definitions, dimensions and tolerances of a taper screw thread of nominal diameter 25,8 mm (designated 25E), for the connection of valves to medical and industrial gas cylinders.

This International Standard does not cover the connection requirements for

- mechanical strength;
- gas tightness;
- capability of repeated assembly and dismounting operations.

Inspection gauges are covered by ISO 11191. [ISO 10920:1997](#)

<https://standards.iteh.ai/catalog/standards/sist/599a44e8-1e86-4b0b-98d8-77cc292489bf/iso-10920-1997>

2 Normative reference

The following standard contains provisions which, through reference in this text, constitute provisions of this International Standard. At the time of publication, the edition indicated was valid. All standards are subject to revision, and parties to agreements based on this International Standard are encouraged to investigate the possibility of applying the most recent edition of the standard indicated below. Members of IEC and ISO maintain registers of currently valid International Standards.

ISO 11191:1997, *Gas cylinders — 25E taper thread for connection of valves to gas cylinders — Inspection gauges.*

3 Definitions

For the purposes of this International Standard, the following definitions apply.

3.1 valve stem: Tapered end of the valve body, with a thread formed on the external surface of the truncated cone (see figure 1).

3.2 cylinder neck thread: Tapered axial hole in the cylinder neck, with a thread formed on the internal surface of the truncated cone (see figure 1).

3.3 major cone: Cone bounding the crests of the thread of the valve stem, or the roots of the cylinder neck thread.

3.4 minor cone: Cone bounding the roots of the thread of the valve stem, or the crests of the cylinder neck thread.

3.5 pitch cone: Cone passing coaxially and midway, between the major and minor cones.

3.6 reference plane A: Reference plane coincident with the small end face, of the threaded valve stem and corresponding to diameters d_{1i} , d_{1p} and d_{1e} (see figure 1).

3.7 reference plane B: Reference plane, at a distance l_1 from reference plane A and corresponding to diameter d_{2p} (see figure 1).

3.8 reference plane F: Reference plane coincident with the entry section face of the cylinder neck thread and corresponding to diameter D_{2p} (see figure 1).

3.9 reference plane G: Reference plane, at a distance L_1 from reference plane F and corresponding to diameters D_{1e} , D_{1p} and D_{1i} (see figure 1).

3.10 major diameter, d_{1e} : Diameter of the major cone, at the valve stem thread reference plane A, (before any chamfer is cut) (see figure 1).

3.11 pitch diameter, d_{1p} : Diameter of the pitch cone, at the valve stem thread, reference plane A, (before any chamfer is cut) (see figure 1).

3.12 minor diameter, d_{1i} : Diameter of the minor cone, at the valve stem thread reference plane A, (before any chamfer is cut) (see figure 1).

3.13 pitch diameter, d_{2p} : Diameter of the pitch cone at reference plane B (see figure 1).

3.14 major diameter, D_{1e} : Diameter of the major cone at reference plane G (see figure 1).

3.15 pitch diameter, D_{1p} : Diameter of the pitch cone at reference plane G (see figure 1).

3.16 minor diameter, D_{1i} : Diameter of the minor cone at reference plane G (see figure 1).

3.17 pitch diameter, D_{2p} : Diameter of the pitch cone at reference plane F (before any chamfer is cut) (see figure 1).

3.18 reference length, l_1 : Reference dimension corresponding to the distance between the parallel reference planes A and B (see figure 1).

3.19 reference length, L_1 : Reference dimension corresponding to the distance between the parallel reference planes F and G (see figure 1).

3.20 length of external thread, l_2 : Length of full form thread, on the valve stem, measured along the cone axis from the reference plane A (see figure 1 and table 1).

3.21 length of internal thread, L_2 : Length of full form thread, in the cylinder neck, measured along the cone axis from the reference plane F (see figure 1 and table 2).

3.22 taper: Ratio of the difference of two diameters corresponding to planes, normal to the axis of the reference cone, and the axial distance between the same planes.

NOTE — It can be expressed as a ratio, as an angle or as a percentage.

3.23 thread profile: Thread shape obtained by the intersection of a plane through the thread axis and the threaded surface.

3.24 basic profile: Theoretical profile, when the profile of the external thread coincides with the profile of the internal thread.

3.25 design profile: Profile different from the basic profile due to the radius of the root, necessary for manufacturing and strength requirements.

NOTE — Manufacturing tolerances are taken into account, for such a profile.

3.26 pitch, P: Distance, measured parallel to the cone surface, between two homologous points of two parallel consecutive flanks of the same thread (see figure 2).

Dimensions in millimetres

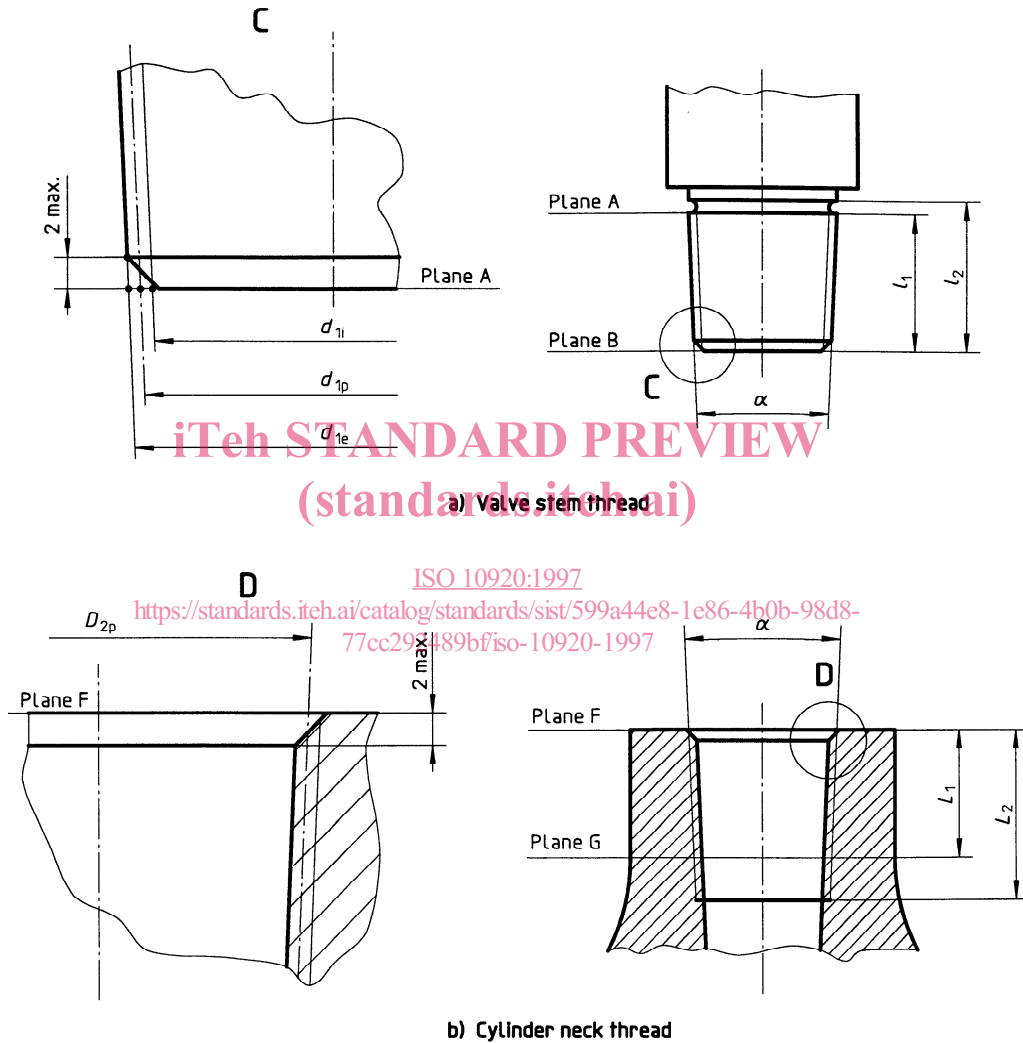

Figure 1 — Thread reference planes and diameters

Table 1 — Valve stem dimensions

Dimensions in millimetres

Valve stem	Major diameter d_{1e}	Pitch diameter d_{1p}	Minor diameter d_{1i}	Pitch diameter d_{2p}	Reference length l_1	Full thread length l_2
Nominal dimension	25,68	24,518	23,356	27,638	26	≥ 26
Tolerance	+ 0,12 0	+ 0,12 0	+ 0,12 0	+ 0,12 0	—	—

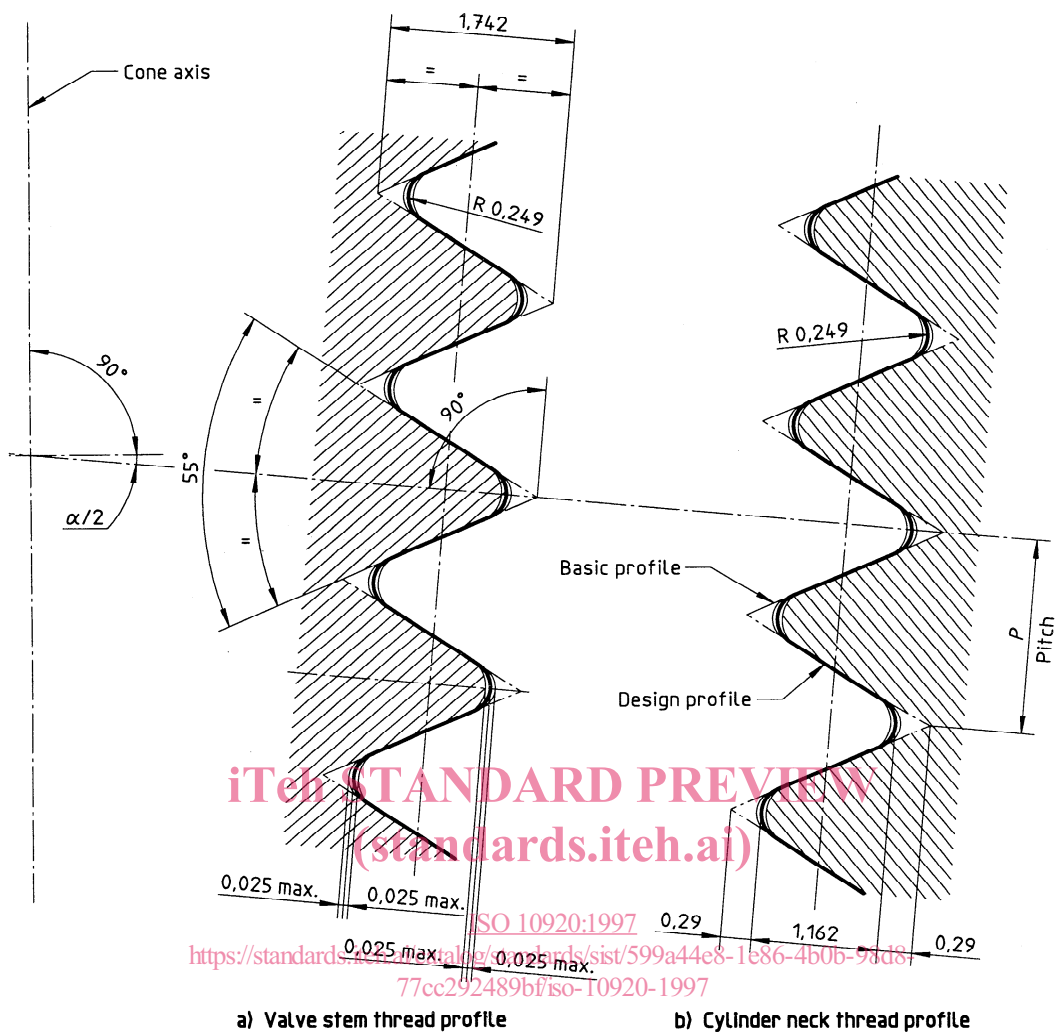

Figure 2 — Thread profiles

Table 2 — Cylinder neck thread dimensions

Dimensions in millimetres

Cylinder neck thread	Major diameter D_{1e}	Pitch diameter D_{1p}	Minor diameter D_{1i}	Pitch diameter D_{2p}	Reference length L_1	Full thread length L_2
Nominal dimension	25,16	23,998	22,836	26,638	22	≥ 22
Tolerance	0 -0,12	0 -0,12	0 -0,12	0 -0,12	—	—

4 Requirements

4.1 Thread rotation

The thread shall be a right hand thread, such that it moves away from an observer when rotated clockwise.

4.2 Thread

The thread shall satisfy the following requirements:

- ratio: 3/25;
- angle: 6° 52′;
- taper: 12 %.

4.3 Thread profile

The thread profile shall be a standard Whitworth form, with a 55° angle. The form and thread height measurements are perpendicular to the cone surface (see figure 2).

4.4 Pitch, *P*

The pitch shall be 1,814 mm (derived from $\frac{25,4}{14}$ mm) (see figure 2).

5 Thread end finish

The thread of the valve stem may have a chamfer of 2 mm maximum, from plane A at the bottom part and a groove at the top (see figure 1).

The thread of the cylinder neck may have a chamfered opening of 2 mm maximum, from plane F (see figure 1).

6 Identification

<https://standards.iteh.ai/catalog/standards/sist/599a44e8-1e86-4b0b-98d8-77cc292489bf/iso-10920-1997>

Valves and cylinders, threaded in accordance with this International Standard, shall be identified by the symbol "25E".