

INTERNATIONAL
STANDARD

ISO
10944

First edition
1998-05-01

Ophthalmic instruments — Synoptophores

Instruments ophtalmiques — Synoptophores

iTeh STANDARD PREVIEW
(standards.iteh.ai)

[ISO 10944:1998](https://standards.iteh.ai/catalog/standards/sist/3ea1d0be-44d6-4fd1-82f9-5900109c16ad/iso-10944-1998)

<https://standards.iteh.ai/catalog/standards/sist/3ea1d0be-44d6-4fd1-82f9-5900109c16ad/iso-10944-1998>



ISO 10944:1998(E)

Foreword

ISO (the International Organization for Standardization) is a worldwide federation of national standards bodies (ISO member bodies). The work of preparing International Standards is normally carried out through ISO technical committees. Each member body interested in a subject for which a technical committee has been established has the right to be represented on that committee. International organizations, governmental and non-governmental, in liaison with ISO, also take part in the work. ISO collaborates closely with the International Electrotechnical Commission (IEC) on all matters of electrotechnical standardization.

Draft International Standards adopted by the technical committees are circulated to the member bodies for voting. Publication as an International Standard requires approval by at least 75% of the member bodies casting a vote.

International Standard ISO 10944 was prepared by Technical Committee ISO/TC 172, *Optics and optical instruments*, Subcommittee SC 7, *Ophthalmic optics and instruments*.

<https://standards.iteh.ai/catalog/standards/sist/3ea1d0be-44d6-4fd1-82f9-5900109c16ad/iso-10944-1998>

© ISO 1998

All rights reserved. Unless otherwise specified, no part of this publication may be reproduced or utilized in any form or by any means, electronic or mechanical, including photocopying and microfilm, without permission in writing from the publisher.

International Organization for Standardization
Case postale 56 • CH-1211 Genève 20 • Switzerland
Internet central@iso.ch
X.400 c=ch; a=400net; p=iso; o=isocs; s=central

Printed in Switzerland

Ophthalmic instruments — Synoptophores

1 Scope

This International Standard, together with ISO 15004, specifies minimum requirements and test methods for synoptophores (also called major amblyoscopes or synoptometers) used to test, measure, train and develop the patient's binocular vision and to measure horizontal, vertical and cyclo deviation in different positions of gaze.

This International Standard takes precedence over ISO 15004, if differences exist.

2 Normative references

The following standards contain provisions which, through reference in this text, constitute provisions of this International Standard. At the time of publication, the editions indicated were valid. All standards are subject to revision, and parties to agreements based on this International Standard are encouraged to investigate the possibility of applying the most recent editions of the standards indicated below. Members of IEC and ISO maintain registers of currently valid International Standards.

ISO 15004:1997	<i>Ophthalmic instruments — Fundamental requirements and test methods</i> ISO 10944:1998
IEC 60601-1:1988	<i>Medical electrical equipment — Part 1: General requirements for safety</i> 5900109c16ad/iso-10944-1998

3 Definitions

For the purposes of this International Standard, the following definitions apply.

3.1 synoptophore

instrument designed to present interchangeable targets to each eye and with the ability to move targets independently in order to present them at different versional and vergence positions

NOTE - Target configuration and location, along with other instrument features, are used to test, measure and train binocular vision.

3.2 visual targets for simultaneous perception

targets used to form two different images, one on each retina, which cannot be fused into a single image

3.3 visual targets for fusion

targets used to form two similar images, one on each retina, which are capable of fusion, and in which control points are often incorporated in order to assess if either eye is suppressing the relevant image

3.4 visual targets for stereoscopic vision

targets used to test and/or measure stereoscopic acuity in which image pairs, having common reference points, are fused in vision to give a stereoscopic effect

3.5 arm

rotatable structural member of the synoptophore intended to carry the ocular systems, targets and illumination system

4 Requirements

4.1 General

The synoptophore shall conform to the requirements specified in ISO 15004.

The synoptophore shall conform to the specific requirements described in 4.2 to 4.5.

These requirements are verified as described in clause 5.

4.2 Optical and mechanical requirements

The requirements specified in table 1 and table 2 shall apply.

iTeh STANDARD PREVIEW
(standards.iteh.ai)

Table 1 — Requirements for adjustment ranges and graduation of scales

Criterion		Requirement
Interpupillary distance	Adjustable range	45 mm to 75 mm
	Graduation	< 1 mm
Horizontal movement of each arm independently	Outward	40°
	Inward	40°
	Graduation	1° or 2Δ ¹⁾
Vertical rotation of each arm independently	Angle of elevation	15°
	Angle of depression	20°
Torsional movement of visual targets (cyclo-)	Clockwise range	20°
	Anticlockwise range	20°
	Graduation	1°
Chin-rest height	Adjustable range from chin-rest top to eyepiece centres	75 mm to 125 mm

1) Δ = prism dioptre equivalent correction at the patient's eye. The actual linear tolerance will depend on the optical path length of the ocular arms.

Table 2 — Adjustment tolerances

Criterion		Tolerance
Interpupillary distance setting		$\pm 0,5$ mm
Lateral alignment of targets at zero setting		$\pm 0,5^\circ$ or $\pm 1\Delta^1$
Vertical alignment of targets at zero setting		$\pm 0,125^\circ$ or $\pm 0,25\Delta^1$
Torsional alignment of targets at zero setting		$\pm 0,5^\circ$
Alignment of targets throughout the horizontal movement range with both arms locked together	Vertically	$\pm 10'$
	Laterally	$\pm 0,5^\circ$
	Torsionally	$\pm 10'$
1) The tolerances given are expressed in degrees when the scale is graduated in degrees, and in prism dioptres when graduated in prism dioptres.		

4.3 Construction and functional requirements

4.3.1 The synoptophore shall be constructed so that it is possible to compensate for the patient's refractive error. If designed to be used with trial case lenses (see ISO 9801¹⁾), the lens holder shall enable the trial case lens to be positioned with an error of not more than 0,5 mm relative to the optical axis of the eyepiece.

4.3.2 The synoptophore shall allow easy location of visual targets in both left and right ocular systems. The targets shall be capable of quick insertion and removal.

4.3.3 The visual targets shall be clearly marked with their identity and orientation.

4.3.4 The luminance of the diffusing screen shall be even and uniform and shall not vary by more than 25 % over the area of the targets.

4.3.5 At maximum illumination settings the average luminance of the right and left diffusing screens shall not differ by more than 20 %.

4.3.6 Each ocular illumination system shall be provided with a variable control to reduce the luminance of the target to 10 % or less of its maximum.

4.3.7 The equipment shall be provided with means for switching off either illumination system independently.

4.3.8 The equipment shall be so constructed that the ocular systems, together or individually (when not locked), can easily be horizontally rotated, without allowing the arms to move of their own accord. The movement shall be smooth and even.

4.3.9 The arms shall be capable of being locked together at a pre-set angle and of being moved together from side to side.

4.3.10 The arms shall be capable of smooth operation independently of one another over the designed range, without affecting the position of the other.

1) ISO 9801:1997, *Ophthalmic instruments — Trial case lenses*.

4.3.11 Sets of visual targets (slides) shall be available for the execution of tests involving simultaneous perception, fusion and stereoscopic vision (see 3.2 to 3.4).

4.3.12 There shall be no noticeable contrast differences in the visual targets caused by internal reflections or scattered light.

5 Test methods

All tests prescribed in this International Standard are type tests.

5.1 Checking the optical, mechanical and functional requirements

5.1.1 The requirements specified in 4.2 and 4.3 shall be verified by the use of measuring devices with accuracy better than 10 % of the smallest value to be determined.

5.1.2 For measuring the respective scales for precision, an angle scale measuring instrument (with a measuring precision of ± 5' or better) shall be used.

5.1.3 The requirements described in 4.3, with the exception of 4.3.4, 4.3.5 and 4.3.6, shall be checked by observation.

5.2 Checking the interpupillary distance

Set the axes of the eyepieces parallel. Measure *A* and *B* shown in figure 1, using vernier callipers (having a precision of 0,1 mm or better) and calculate the interpupillary distance IPD using the equation:

$$IPD = \frac{A + B}{2}$$

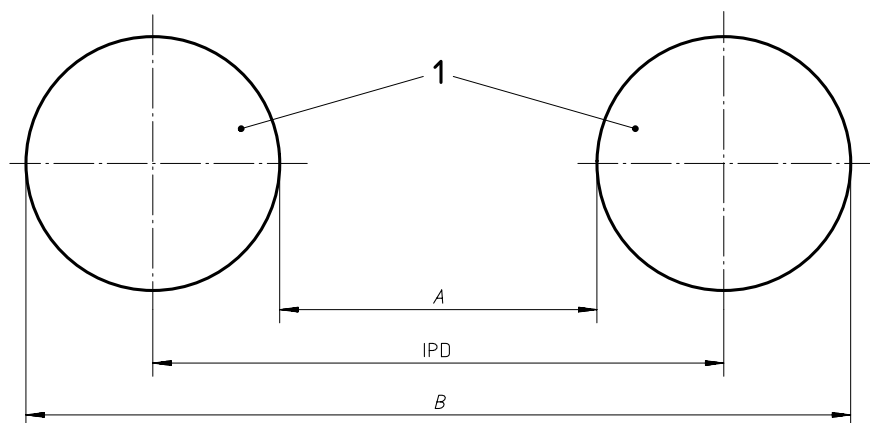

Key
1 Eyepieces

Figure 1 — Test configuration for measuring the interpupillary distance

5.3 Checking the axes' alignment

Insert a pair of cross-wire targets into the instrument.

Set the left and right ocular systems at 0° for horizontal, vertical and torsional deviations.

Mount +1,00 D test lenses before both eyepieces so that the crosses are projected onto a screen at a distance of 1 m. Vertical or torsional deviations are present if the projected targets cannot be brought to coincidence by converging the tubes.

To measure a horizontal deviation, set the two arms parallel (0°), and measure the separation of the two crosses on the screen. Check that the separation is the same as the interpupillary distance of the synoptophore.

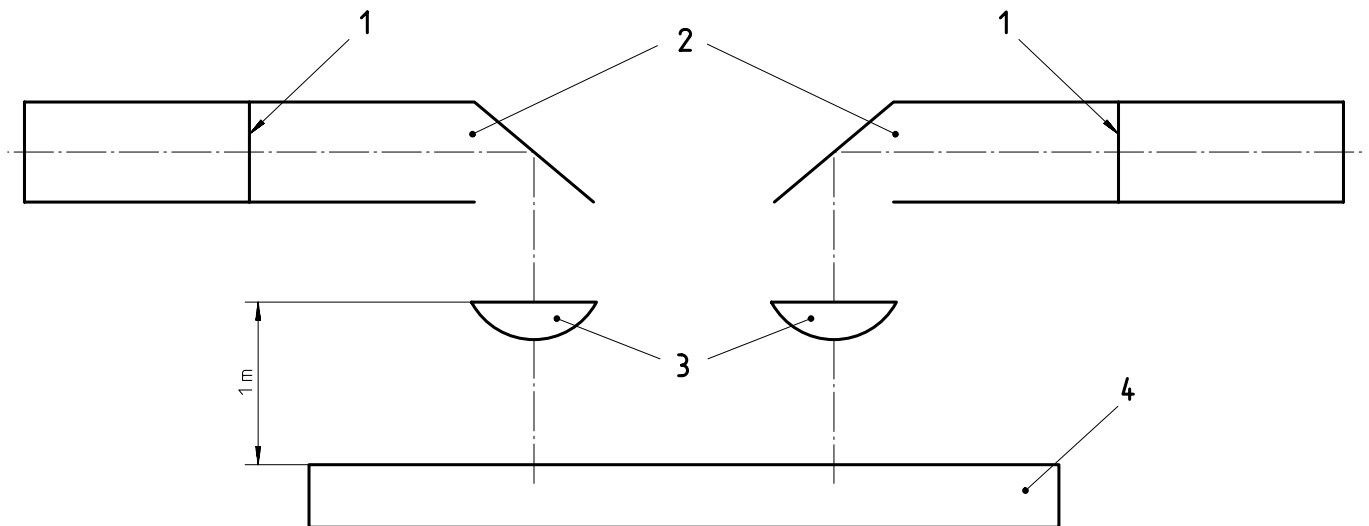

Key

- 1 Slide
- 2 Synoptophore arms
- 3 Lenses
- 4 Screen

iTeh STANDARD PREVIEW
(standards.iteh.ai)
ISO 10944:1998
<https://standards.iteh.ai/catalog/standards/sist/3ea1d0be-44d6-4fd1-82f9-590909c16ad/iso-10944-1998>
Figure 2 — Test configuration for measuring the axes' alignment

5.4 Checking the chin-rest height

Measure the distance from the chin-rest top to the horizontal line through the eyepieces' centres, using a calliper with a measuring precision of 0,1 mm or better.

6 Accompanying documents

The synoptophore shall be accompanied by documents containing instructions for use. In particular, this information shall contain:

- a) name and address of the manufacturer;
- b) instructions for effective disinfection of the synoptophore, with particular reference to the disinfection of instruments returned to the manufacturer for repair and maintenance;
- c) if appropriate, a statement that the synoptophore in its original packaging conforms to the transport conditions as specified in 5.3 of ISO 15004:1997;
- d) any additional documents as specified in 6.8 of IEC 60601-1:1988.

7 Marking

The synoptophore shall be permanently marked with at least the following information:

- a) name of manufacturer or supplier;
- b) name and model of synoptophore;
- c) marking as required by IEC 60601-1;
- d) a reference to this International Standard, i.e. ISO 10944, if the manufacturer or supplier claims compliance with it.

iTeh STANDARD PREVIEW
(standards.iteh.ai)

ISO 10944:1998

<https://standards.iteh.ai/catalog/standards/sist/3ea1d0be-44d6-4fd1-82f9-5900109c16ad/iso-10944-1998>

iTeh STANDARD PREVIEW
(standards.iteh.ai)

ISO 10944:1998

<https://standards.iteh.ai/catalog/standards/sist/3ea1d0be-44d6-4fd1-82f9-5900109c16ad/iso-10944-1998>