



Designation: C 635 – 00

Standard Specification for the Manufacture, Performance, and Testing of Metal Suspension Systems for Acoustical Tile and Lay-in Panel Ceilings¹

This standard is issued under the fixed designation C 635; the number immediately following the designation indicates the year of original adoption or, in the case of revision, the year of last revision. A number in parentheses indicates the year of last reapproval. A superscript epsilon (ϵ) indicates an editorial change since the last revision or reapproval.

This standard has been approved for use by agencies of the Department of Defense.

1. Scope

1.1 This specification covers metal ceiling suspension systems used primarily to support acoustical tile or acoustical lay-in panels.

1.2 Some suspension systems incorporate locking assembly details that enhance performance by providing some continuity or load transfer capability between adjacent sections of the ceiling grid. The test methods included in this specification do not provide the means for making a complete evaluation of continuous beam systems, nor for assessing the continuity contribution to overall system performance. However, the test methods can be used for evaluating primary structural members in conjunction with secondary members that interlock, as well as with those of noninterlocking type.

1.3 While this specification is applicable to the exterior installation of metal suspension systems, the atmospheric conditions and wind loading require additional design attention to ensure safe implementation. For that reason, a specific review and approval should be solicited from the responsible architect and engineer, or both, for any exterior application of metal suspension systems in the construction of a new building or building modification.

1.4 The values stated in inch-pound units are to be regarded as the standard. The values given in parentheses are provided for information purposes only.

1.5 The following safety hazards caveat pertains only to the test methods described in this specification. *This standard does not purport to address all of the safety concerns, if any, associated with its use. It is the responsibility of the user of this standard to establish appropriate safety and health practices and determine the applicability of regulatory limitations prior to use.*

¹ This specification is under the jurisdiction of ASTM Committee E-33 on Environmental Acoustics and is the direct responsibility of Subcommittee E33.04 on Application of Acoustical Materials and Systems.

Current edition approved May 10, 2000. Published August 2000. Originally published as C 635 – 69. Last previous edition C 635 – 97.

2. Referenced Documents

2.1 *ASTM Standards:*

B 117 Practice for Operating Salt Spray (Fog) Apparatus²

3. Terminology

3.1 *Definitions:*

3.1.1 Where these terms appear in this specification they shall have the meaning herein indicated as follows:

3.1.1.1 *backing board*— a flat sheet of gypsum board to which acoustical tile is attached using adhesive, screws, staples, or other suitable means (Fig. 1c).

3.1.1.2 *bow*—the maximum component of deviation in the vertical plane of a main runner, cross runner, or wall molding where the centroidal axis of these structural components has been permanently deformed from end to end into the shape of a simple regular curve during the manufacturing process (Fig. 2).

NOTE 1—The meanings for *bow* and *camber* given here may differ from those applied elsewhere.

3.1.1.3 *camber*—the maximum component of deviation in the horizontal plane of a main runner, cross runner, or wall molding where the centroidal axis of these structural components has been permanently deformed from end to end into the shape of a simple regular curve during the manufacturing process (Fig. 2).

3.1.1.4 *carrying channel or hanging channel*—the three-sided or “[”-shaped metal sections that support the entire structural grid network in some forms of mechanical ceiling suspension systems (Fig. 1b). The carrying channels are usually suspended by hanger wires from the existing structure and the main runners are then attached to the channels.

3.1.1.5 *ceiling suspension system*—the entire network or grid of structural components, as defined by the ceiling suspension system manufacturer, that provides support for

² *Annual Book of ASTM Standards*, Vol 03.02.

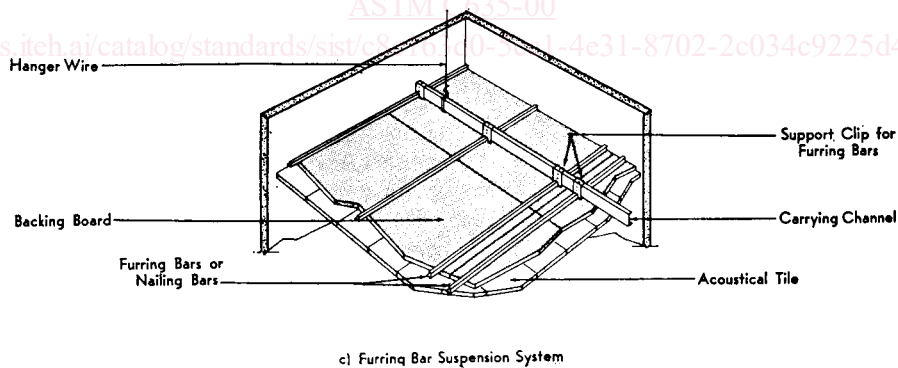
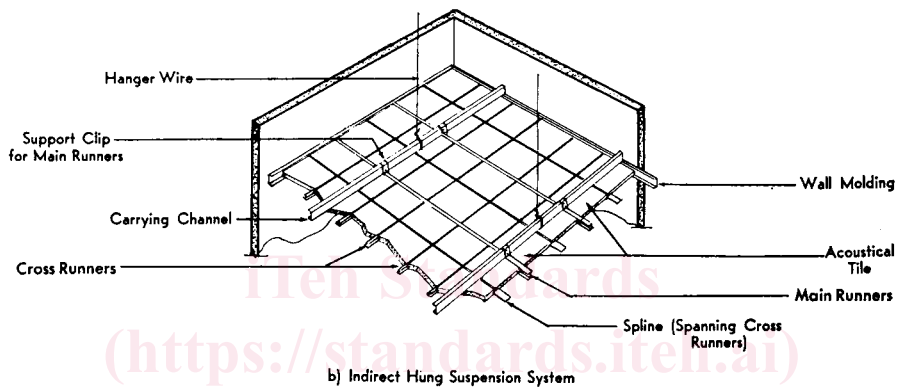
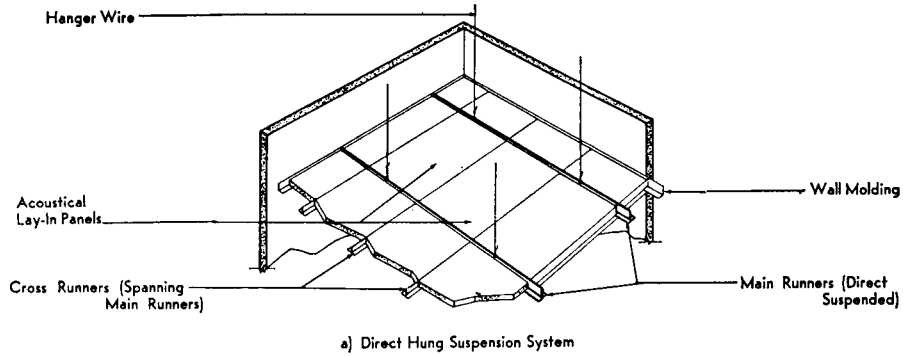

FIG. 1 Three Types of Ceiling Suspension Systems Showing All Components

acoustical ceiling tile, acoustical ceiling panels, lighting fixtures, and air diffusers.

3.1.1.6 *cross runner*— the secondary or cross beams of a mechanical ceiling suspension system (Fig. 1, a and b). The cross runners usually support only the acoustical tile. In some forms of suspension systems, however, the cross runners also provide support for lighting fixtures, air diffusers, and other cross runners.

3.1.1.7 *hanger wire*— the wire employed to suspend the acoustical ceiling from the existing structure (wood joists, steel bar joists, steel beams, concrete slabs, etc.) (Fig. 1).

3.1.1.8 *horizontal plane* (of a structural component of a ceiling suspension system)—a plane parallel to the plane of the ceiling which passes through the centroidal axis of the member (Fig. 2).

3.1.1.9 *interlocking*—a ceiling system where the cross runners are connected to the main runner or other cross runners, or both, at intervals controlled by slots, holes, etc. in the main runners.

3.1.1.10 *main runner*— the primary or main beams of the type of ceiling suspension system in which the structural members are mechanically locked together (Fig. 1, a and b).

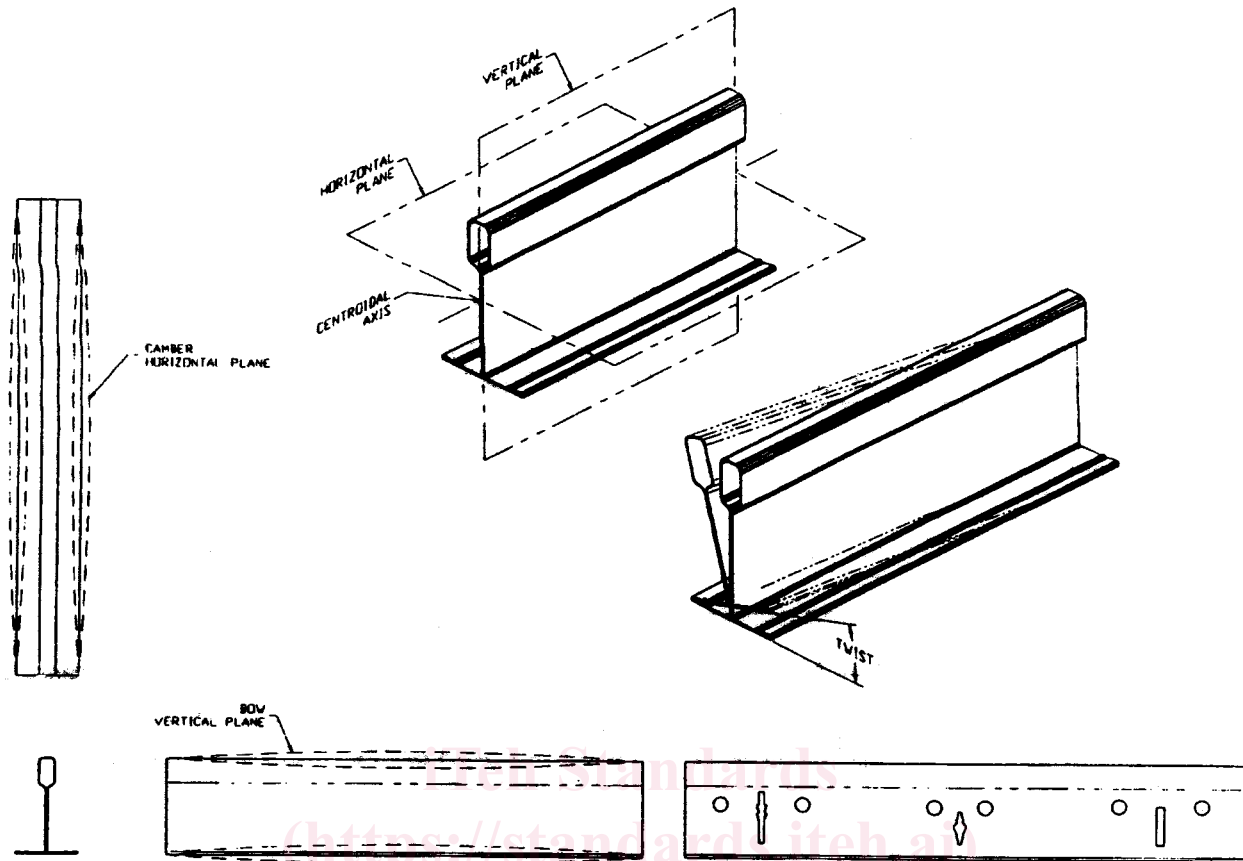

FIG. 2 Diagrams Showing Camber, Bow, and Twist

The main runners provide direct support for cross runners, and may support lighting fixtures and air diffusers. In addition, the acoustical tile may also be directly supported by the main runners. In some forms of mechanical ceiling suspension systems, the main runners are supported by hanger wires attached directly to the existing structure. In other forms, the main runners (also referred to as “H” runners, “Z” bars, etc.) are installed perpendicular to carrying channels and are supported by specially designed sheet metal or wire clips attached to the carrying channels.

3.1.1.11 *nailing bar or furring bar*—the continuous sheet metal strips to which a backing board is attached using either nails or screws (Fig. 1c). The nailing bars are installed perpendicular to and supported by the carrying channels.

3.1.1.12 *non-interlocking*—a ceiling system that does not comply with the specifications stated in the definition of interlocking.

3.1.1.13 *spline*—a strip of metal or fiber inserted in the kerfs of adjacent acoustical tile to form a concealed mechanical joint seal (Fig. 1b).

3.1.1.14 *twist*—the angle of rotation measured in a transverse plane between the two end cross sections of a main runner, cross runner, or wall molding which has been permanently deformed during the process of manufacturing (Fig. 2).

3.1.1.15 *vertical plane* (of a structural component of a ceiling suspension system)—a plane perpendicular to the plane of the ceiling which passes through the centroidal axis of the member (Fig. 2).

3.1.1.16 *wall molding*—the edge angles or channels of a mechanical ceiling suspension system that are attached to a wall (Fig. 1, a and b). The wall molding provides support for the acoustical tile, main runners and cross runners that are located at the periphery of the ceiling.

4. Classification

4.1 The structural performance required from a ceiling suspension system shall be defined by the specifying authority in terms of a suspension system structural classification.

4.1.1 The structural classification of ceiling suspension systems shall be based on the load-carrying capacity of the main runners of the structural network. Load-carrying capacity as used herein is based on the more stringent requirement of esthetic acceptance rather than the less confining prevention of structural failure. The criterion is the arbitrary but widely established limit of deflection to $\frac{1}{360}$ of the span between supports.

4.1.2 The load-carrying capacity shall be the maximum uniformly distributed load (pounds per linear foot) that a simply supported main runner section having a span length of

4 ft, 0 in. (1.219 m) is capable of supporting without the mid-span deflection exceeding 0.133 in. (3.38 mm) or $\frac{1}{360}$ of the 4 ft, 0 in. span length, as tested in accordance with the method described in Section 8.

4.1.3 The structural classification or grade of ceiling suspension systems shall be determined by the capability of main runners or nailing bars to support a uniformly distributed load. These classifications shall be:

4.1.3.1 *Light-Duty Systems*, used where ceiling loads other than acoustical tile or lay-in panels are not anticipated, such as residential and light commercial structures.

4.1.3.2 *Intermediate-Duty Systems*, used where ceiling loads other than acoustical tile or lay-in panels (light fixtures, air diffusers, etc.) are anticipated, such as ordinary commercial structures.

4.1.3.3 *Heavy-Duty Systems*, used where the quantities and weights of ceiling fixtures (lights, air diffusers, etc.) are greater than those for an ordinary commercial structure.

4.1.4 For the purpose of determining the structural classification of main runner members as covered in 4.1.2, their simple-span, minimum load-carrying capabilities, when tested in accordance with the test method described in Section 10, shall be listed as shown in Table 1.

4.2 Cross runners shall be capable of carrying the load specified by the manufacturer without exceeding the maximum allowable deflection equal to $\frac{1}{360}$ of its span.

4.3 The design and definition of the suspension system shall be the responsibility of the manufacturer. Included is selection of appropriate materials, metal thicknesses, dimensions of necessary component section configurations, design of special hanger and assembly devices, and provision for whatever accessory items are needed to ensure satisfactory ceiling performance within the scope of this specification.

4.3.1 System manufacturers may provide supplementary data describing load deflection capabilities of main runners in each classification for spans other than 4 ft (1.2 m).

4.4 Where specialized loading conditions that are outside the scope of this specification exist, the manufacturer should be consulted for his recommendations; and, he may furnish engineering data as required. Specification or design of super-structure anchors or fasteners are not the responsibility of the ceiling system manufacturer unless specified by the ceiling system manufacturer as part of the suspension system.

5. Dimensional Tolerance

5.1 Suspension system *structural members* shall conform to the following tolerance requirements:

5.1.1 Metal Thickness:

5.1.1.1 For *steel systems* the thickness of metal used in main runners, cross runners, wall moldings, splines or nailing bars

shall be stated by the suspension system manufacturer in published literature. The thickness in thousandths of an inch of metal and the allowable thickness variation for the component shall be stated.

5.1.1.2 For *aluminum systems* the thickness of metal used in main runners, cross runners, wall moldings, or splines shall be stated by the suspension system manufacturer in published literature. The thickness in thousandths of an inch of metal and the allowable thickness variation for the component shall be stated.

5.1.2 Straightness:

5.1.2.1 The amount of bow, camber, or twist in main runners, cross runners, wall molding, splines, or nailing bars of various lengths shall not exceed the values shown in Table 2.

5.1.2.2 Main runners, cross runners, wall moldings, splines, or nailing bars of ceiling suspension systems shall not contain local kinks or bends.

5.1.3 Length:

5.1.3.1 The variation in the specified length of main runner sections or cross runner sections that are part of an interlocking grid system shall not exceed ± 0.010 in./4 ft (0.21 mm/m).

5.1.3.2 The variation in the specified spacing of slots or other cutouts in the webs of main runners or cross runners that are employed in assembling a ceiling suspension grid system shall not exceed ± 0.010 in. (0.25 mm).

5.1.4 Over-all Cross-section Dimensions:

5.1.4.1 For *steel systems*, the overall height of the cross section of main runners, cross runners, wall molding, or nailing bar shall be the specified dimensions ± 0.030 in. (0.76 mm). The width of the cross section of exposed main runners or cross runners shall be the specified dimension ± 0.008 in. (0.20 mm).

5.1.4.2 For *aluminum systems*, the overall height of the cross section and the allowable variation of main runners, cross runners, or wall molding shall be stated by the suspension system manufacturer in published literature and price lists. The width and allowable variation of the cross section of exposed main runners or cross runners shall be similarly stated.

5.1.5 Section Squareness:

5.1.5.1 Intersecting webs and flanges of structural members ("I", "T", or "Z" sections) shall form angles between them of $90 \pm 2^\circ$. If deviations from squareness at more than one such intersection are additive with respect to their use in a ceiling, the total angle shall not be greater than 2° .

5.1.5.2 The ends of structural members that abut or intersect other members in exposed grid systems shall be cut perpendicular to the exposed face, $90^\circ + 0, - 2^\circ$.

5.2 Suspension system assembly devices shall satisfy the following requirements and tolerances.

5.2.1 The design of and dimensional tolerances set by the manufacturer for accessory items such as formed wire hangers, spring spacer clips, tile retainers, and spacer bars shall be such

TABLE 1 Minimum Load-Carrying Capabilities of Main Runner Members

Main Runner Members	Suspension System lb/linear ft (kg/m)		
	Direct Hung	Indirect Hung	Furring Bar
Light-duty	5.0 (7.4)	2.0 (3.0)	4.5 (6.7)
Intermediate-duty	12.0 (17.9)	3.5 (5.1)	6.5 (9.7)
Heavy-duty	16.0 (23.8)	8.0 (11.9)	...

TABLE 2 Straightness Tolerances of Structural Members of Suspension Systems

Deformation	Straightness Tolerances
Bow	$\frac{1}{32}$ in. in any 2 ft (1.30 mm/m)
Camber	$\frac{1}{32}$ in. in any 2 ft (1.30 mm/m)
Twist	1° in any 2 ft (1.64°/m)