



**Designation: E 476 – 87 (Reapproved 1993)**

AMERICAN SOCIETY FOR TESTING AND MATERIALS  
100 Barr Harbor Dr., West Conshohocken, PA 19428  
Reprinted from the Annual Book of ASTM Standards. Copyright ASTM

# Standard Test Method for Thermal Instability of Confined Condensed Phase Systems (Confinement Test)<sup>1</sup>

This standard is issued under the fixed designation E 476; the number immediately following the designation indicates the year of original adoption or, in the case of revision, the year of last revision. A number in parentheses indicates the year of last reapproval. A superscript epsilon ( $\epsilon$ ) indicates an editorial change since the last revision or reapproval.

## INTRODUCTION

This test method is one of several methods developed by Committee E-27 for determining the hazards of chemicals. This test method is to be used in conjunction with other tests to characterize the hazard potential of chemicals.

## 1. Scope

1.1 This test method<sup>2</sup> is designed to determine the temperature at which a chemical or mixture of chemicals, confined initially as a solid or liquid in air or other controlled atmosphere under normal laboratory conditions, will start a reaction, generating appreciable heat when subjected to a programmed temperature increase. This test method is also designed to measure the magnitude and rate of heat generation.

1.2 This test method is for use with condensed phases.

1.3 This test method can be used over a temperature range from 0 to 500°C, and a pressure range of 0 to 5000 psi.

1.4 As with any thermal stability test, proper safety precautions should be instituted to protect personnel. See also Section 6.

1.5 *Limitations:*

1.5.1 The threshold temperature determined by this method may be higher than one determined by heating at a lesser rate.

1.5.2 Samples of the same material having different thermal histories may have different threshold temperatures.

1.6 *This standard may involve hazardous materials, operations, and equipment. This standard does not purport to address all of the safety problems associated with its use. It is the responsibility of the user of this standard to establish appropriate safety and health practices and determine the applicability of regulatory limitations prior to use.*

## 2. Terminology

2.1 *threshold temperature*—temperature on the  $\Delta T$  versus  $T$

<sup>1</sup> This test method is under the jurisdiction of Committee E-27 on Hazard Potential of Chemicals and is the direct responsibility of Subcommittee E 27.02 on Thermal Stability.

Current edition approved Sept. 25, 1987. Published November 1987. Originally published as E 476 – 73. Last previous edition E 476 – 73 (1979)<sup>2</sup>.

<sup>2</sup> This test method is a modification of the Thermal Stability Test recommended by the Interagency Chemical Rocket Propulsion Group, published by the Chemical Propulsion Information Agency in May, 1964, and is the responsibility of E 27.02 on Thermal Stability.

curve (see Fig. 2) where the slope changes in the direction indicating an exothermic reaction, that is, the sample is beginning to self-heat.

## 3. Summary of Method

3.1 The sample is confined in a specially designed vessel equipped with a shielded thermocouple. The test assembly is put into a bath and equilibrated, usually at room temperature. The bath is then heated at a constant temperature rise rate. The differential temperature (sample temperature minus bath temperature) in the vessel is recorded versus bath temperature. Heating is continued until the diaphragm bursts or the upper temperature limit is reached. The differential temperature curve is then analyzed to determine the threshold temperature for initiation of measurable reaction as indicated by an exothermic temperature rise.

## 4. Significance and Use

4.1 The threshold temperature measured by this test method is an indication of the thermal instability of a chemical or mixture of chemicals, qualitatively expressed by the temperature rise. There is a potential hazard whenever the temperature of the chemical exceeds the threshold temperature unless proper design safeguards are utilized. This does not imply that temperatures lower than the threshold temperature are safe. Since this test is not an adiabatic type and does not indicate the effect of mass or time, other testing would be needed to characterize the use or storage of the chemical at lower temperatures.

4.2 Because of rate and mass dependent factors, failure to find evidence of an exothermic reaction does not ensure thermal stability unless substantiated by other test methods.

## 5. Apparatus

5.1 *Sample Container*—A diagram of a suggested test cell assembly is shown in Fig. 3 and an engineering drawing is shown in Fig. 4. The assembly shall consist of the following

MODIFY ONE END OF 1/4" AN TUBE UNION AS SHOWN  
(PARKER 4HBTX-SS OR EQUIVALENT)

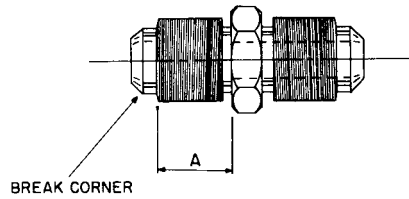

THERMAL STABILITY BOMB CONNECTOR

TABLE OF DIMENSIONS				
IN.		MM		
DIMENSION	TOLERANCE	DIMENSION	TOLERANCE	
A	0.420	10.67	0.13	
B	0.003	0.08		
C	0.363	9.20	+0.05	-0.05
D	0.010	0.25		
E	0.219	5.52	0.38	
F	0.362	9.19	0.38	

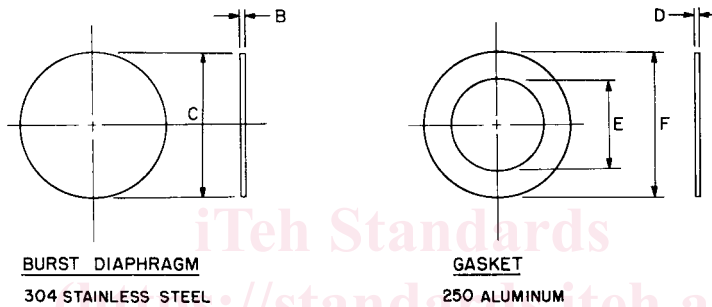

BURST DIAPHRAGM  
304 STAINLESS STEEL

GASKET  
250 ALUMINUM

FIG. 1 Connector, Gasket, and Burst Diaphragm

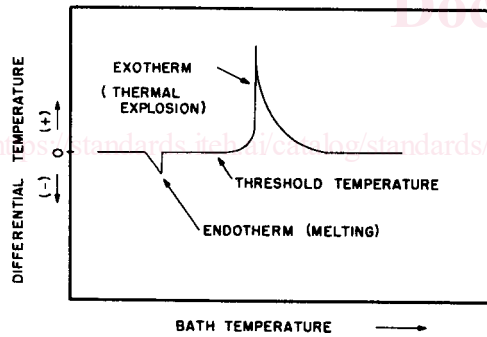

FIG. 2 Idealized Thermogram

parts: basic test cell, sample thermocouple, compression fitting, sealing ring, burst diaphragm, modified Army-Navy specification union (AN union), vent tube and flare fitting. Detailed dimensions of all parts are given in Fig. 4 with the exception of those parts readily available from manufacturers. The parts are listed in Table 1. The internal volume of the assembled test cell is approximately 1.1 mL.<sup>3,4</sup>

5.2 Instrumentation:

5.2.1 One recorder is used for recording the difference between the sample temperature and the bath temperature as a

<sup>3</sup> Apparatus of similar designs with a total volume of 1 to 10 mL can be used.  
<sup>4</sup> This revised test method, when used with its provision for optional pressure measurement, is essentially similar to earlier versions of this in which pressure measurement was an integral part.

function of bath temperature. A suitable recorder for this test is a standard 8.5 by 11 in. X-Y plotter. Two recorders are required if pressure versus bath temperature is monitored. Dual-pen plotters are suitable, provided the temperature pens do not interact at any critical junction of the reaction.

5.2.2 The maximum reaction rates that can be followed using the recommended instrumentation are limited by the writing speeds of the mechanical writing recorders. When these are calibrated as described in Section 8, rates of reaction producing temperature changes of 5°C per s can be determined. Certain reactions may cause temperature changes in excess of these. If more exact resolution for rapid reactions is desired, it is necessary to use a recording oscillograph in place of the X-Y recorder.

5.3 Low-Range Heating Bath—For temperatures from 0 to 370°C the bath may be a conventional 2-L silicon oil<sup>5</sup> unit with heaters (1800 W), stirring motor, and temperature programmer. The bath container shall be metal with strip heaters on the outside. The bath shall be well insulated. A cooling coil shall be wrapped around the container to reduce the time lost between tests (optional). The coolant shall be tap water. The nominal heating rate for the bath shall be 8 to 10°C per min.

5.4 High-Range Heating Bath—For temperatures between 100 and 500°C a bath of a low-melting alloy may be employed. The bath medium may be cerrobend/Alloys or Woods' metal (**Caution.** Woods' metal may contain cadmium and should be

<sup>5</sup> Dow Corning 710 has been found satisfactory for this purpose.

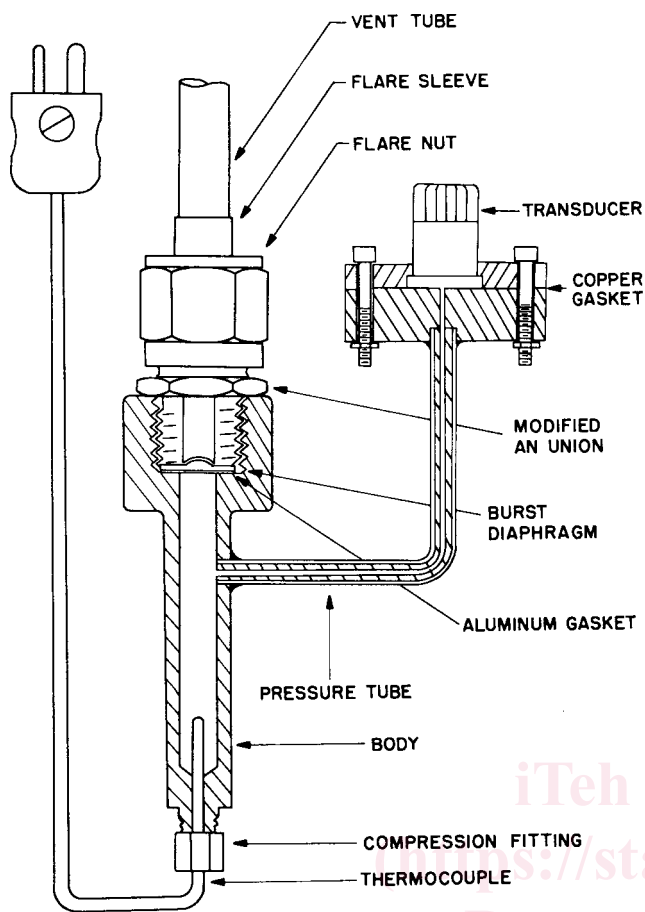

FIG. 3 Thermal Stability Bomb Assembly

used with adequate ventilation to remove toxic fumes). A temperature programmer is also employed with the metal bath. The nominal heating rate for the metal bath is 8 to 10°C per min. This heating rate may prove difficult to maintain above 400°C unless the bath is well protected from air currents.

5.5 *Full-Range Heating Bath*—A fluidized sand bath equipped with vacuum dust ring may be conveniently used for the full range of temperatures. However, without additional heaters, it appears that commercial units are designed for a heatup rate of about 5°C per min.

5.6 **Warning**—Coiled electric heaters may cause electrical interference with electronic measuring equipment. X-Y recorders can pick up stray currents unless shielded thermocouple leads are used and shielding, bath and recorders are grounded to a common ground potential.

## 6. Safety Precautions

6.1 After placing the sample in the test cell, exercise caution to ensure that the threaded parts of the apparatus are clean before final assembly. For some sensitive materials, sample material caught in the threads may detonate and may set off the bulk of the sample in the test vessel. Serious injury to personnel may result.

6.2 It may be necessary to powder the sample (see 7.2) or, since the packing density of solids varies over a wide range, to compact the sample in the cell. These operations may be hazardous and should not be performed unless a determination

of impact sensitivity<sup>6</sup> has previously been made and has shown sufficient insensitivity to permit powdering or compaction.

6.3 Upon rupture of the diaphragm, noxious fumes may be released into the laboratory. To prevent escape of the reaction products into the laboratory atmosphere, conduct tests either in a fume hood or pipe the vent line to a suitable exhaust system.

6.4 The bath of hot oil or molten metal may inadvertently be spilled or ruptured and cause personnel burns or laboratory fires. To prevent such accidents, the test unit should be located in a separate fume hood constructed of non-combustible materials. The use of a fluidized sand bath minimizes this particular hazard.

6.5 During the test, certain sensitive chemicals may detonate resulting in destruction of the basic test cell assembly and possible destruction of the bath. Such violent reactions frequently hurl fragments through the surroundings at high velocity with great danger to personnel. To prevent injury from possible shrapnel, conduct tests in a barricaded enclosure or behind a blast shield contained within a fume hood.

6.6 All controls and switches should be on the operator side of the blast shield or enclosure so that during emergencies, steps can be taken to turn off heaters and shut down the system without exposing personnel to danger.

6.7 A loud report accompanies the rupture of a burst diaphragm; this may cause accidents by startling personnel engaged in other tasks. Although the use of fume hoods and blast shields muffles the sound, all nearby personnel should be warned that the test is in progress prior to running the test.

6.8 Give thought to procedures for cooling. If water is to be used for cooling, care is needed since in most instances, the temperatures of the bath will be much higher than the boiling point of water.

6.9 In some cases the pressure may not be sufficient to burst the pressure diaphragm. On cooling to room temperature, there may still be a high residual pressure in the test cell. Take care in relieving pressure from the cell. The operator should be protected by a shield and have protective covering for eyes, arms and hands.

NOTE 1—It would be judicious to insert a suitably pressure-rated valve on the cell to allow a controlled venting of pressure. Cracking of the union nut may allow gas-saturated liquid contents to rapidly leave the cell.

## 7. Test Sample

7.1 It is recommended that a sample weight of 0.3 g be used. The sample size has been chosen so that the thermal expansion of most substances will not cause the sample volume to exceed the volume of the cell. In cases where thermal expansion is a problem, lower weights of sample may be used and reported.

7.2 Solid samples should be powdered. A particle size of 50 mesh or smaller is preferred.

## 8. Procedure

8.1 Review Section 6 carefully before proceeding.

8.2 Calibrate the X-Y recorder with a potentiometer from 0 to 500°C on the X-axis. Calibrate the differential temperature trace to 10°C per 25 mm or 10°C per in. on the Y-axis. Offset the base line for a 20°C endothermic deflection.

<sup>6</sup> An ASTM Standard for determining impact sensitivity is under development.