



Standard Test Method for Dust Explosions in a 1.2-Litre Closed Cylindrical Vessel¹

This standard is issued under the fixed designation E 789; the number immediately following the designation indicates the year of original adoption or, in the case of revision, the year of last revision. A number in parentheses indicates the year of last reapproval. A superscript epsilon (ϵ) indicates an editorial change since the last revision or reapproval.

1. Scope

1.1 This test method covers the determination of the ignition of a dust dispersed in air, within a closed vessel.

1.2 This test method provides a measure of dust explosion pressure and rate of pressure rise. It does not provide a definitive determination of the flammability of a dust and has other severe limitations which are identified in Section 5. The preferred method for the design of safety equipment is Test Method E 1226.

1.3 *This standard does not purport to address all of the safety concerns, if any, associated with its use. It is the responsibility of the user of this standard to establish appropriate safety and health practices and determine the applicability of regulatory limitations prior to use. For specific safety precautions see Section 7.*

1.4 The values stated in inch-pound units are to be regarded as the standard. The values in parentheses are for information only.

2. Referenced Documents

2.1 ASTM Standards:

D 3173 Test Method for Moisture in the Analysis Sample of Coal and Coke²

D 3175 Test Method for Volatile Matter in the Analysis Sample of Coal and Coke²

E 1226 Test Method for Pressure and Rate of Pressure Rise for Combustible Dusts³

2.2 Other ASTM Document:

STP 447A Manual on Test Sieving Methods⁴

3. Summary of Test Method

3.1 A dust cloud is formed in a closed steel combustion chamber by a jet of clean compressed air and ignited by a continuous electric arc.

3.2 The pressure is detected by a transducer and recorded by appropriate measuring equipment from which pressure and rate of pressure rise may be determined.

4. Significance and Use

4.1 This test method provides a procedure for measuring pressure and rate of pressure rise.

4.2 This test method may be used to determine whether a dust will ignite using an electric arc ignition source.

5. Limitation

5.1 The values determined by this test method are specific to the material tested and equipment and procedure used and are not to be considered inherent, fundamental properties.

5.2 The size and shape of the vessel have a direct bearing on the data obtained. Extrapolation to vessels having a different volume and shape should not be made.

5.3 The data cannot be used for direct calculation of explosion venting or containment.

5.4 A dust cloud that does not ignite by this test method may still be flammable. This test method does not provide a definitive determination of the flammability of a dust.

6. Apparatus

6.1 The equipment consists of a vertically mounted closed steel combustion chamber (commonly known as the Hartmann tube), a dust dispersion system using clean air, ignition source, pressure sensor, and recording system.

6.2 Fig. 1 is a schematic diagram of the apparatus.

6.3 Construction details and tables are presented in the annexes.

6.4 The pressure transducer should be installed and operated according to the manufacturer's recommendations.

7. Safety Precautions

7.1 Prior to handling a dust material, the toxicity of the sample and its combustion products must be considered; this information is generally obtained from the manufacturer or supplier. Appropriate safety precautions must be taken if the material has toxic or irritating characteristics. Tests using this apparatus must be in a ventilated hood or other area having adequate ventilation.

7.2 Before initiating a test check and secure the Hartmann apparatus, fittings, and gaskets to prevent leakage.

7.3 All testing should start using 0.1 g of sample to prevent over-pressurization due to high-energy materials. No experiments should be run so that the explosion pressure exceeds 175 psig (1.21 MPa).

7.4 In assembling the electrical circuitry for this apparatus,

¹ This test method is under the jurisdiction of ASTM Committee E-27 on Hazard Potential of Chemicals and is the direct responsibility of Subcommittee E27.05 on Dusts.

Current edition approved Nov. 10, 1995. Published January 1996. Originally published as E 789 – 81. Last previous edition E 789 – 89.

² Annual Book of ASTM Standards, Vol 05.05

³ Annual Book of ASTM Standards, Vol 14.02.

⁴

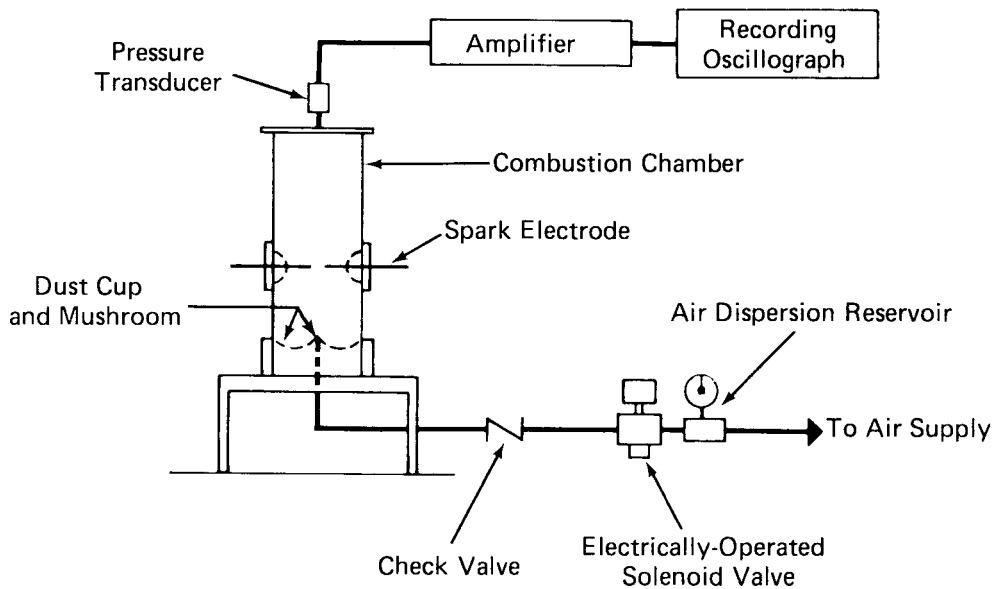

NOTE 1—Cam switch timer operates solenoid valve, spark ignition, and recording oscillograph.

FIG. 1 Schematic of Apparatus for Determining Pressure and Rate of Pressure in a Dust Explosion

standard wiring and grounding procedures must be followed. Since the high-voltage spark circuit presents an electric shock hazard, adequate interlock and shielding must be employed to prevent contact.

7.5 All enclosures containing electrical equipment should be connected to a common ground, and shielded cables should be used.

7.6 The operator should work from a protected location in case of vessel or electrical failure.

8. Sampling and Test Specimen

8.1 It is not practical to specify a single method of sampling dust for test purposes since the character of the material and its available form affect selection of the sampling procedure. Generally accepted sampling procedures should be used as described in STP 447A.

8.2 Tests may be run on an as-received sample. However, due to possible accumulation of fines at some location in a processing system, it is recommended that the test sample be at least 95 % minus 200 mesh (74 μm).

NOTE 1—It may be desirable in certain instances to conduct dust explosion tests on materials as sampled from a process, since (a) process dust streams may contain a wide range of particle sizes or have a well-defined specific moisture content making it desirable to test the material in the as-received state, (b) materials consisting of a mixture of chemicals may be selectively separated on sieves making it desirable to test the as-received material, (c) certain fibrous materials which may not pass through a relatively coarse screen may produce dust explosions if tested in the as-received state, (d) when a material is tested in the as-received state it should be recognized that the test results may not represent the most severe dust explosion possible. Any process change resulting in a higher fraction of fines than normal or drier product than normal will increase the potential hazard from dust explosions.

8.3 To achieve this particle fineness (≥ 95 % minus 200 mesh) the sample may be ground or pulverized or it may be sieved.

NOTE 2—The operator should consider the thermal stability of the dust

during any grinding or pulverizing. In sieving the material, the operator must verify that there is no selective separation of components in a dust that is not a pure substance.

8.4 The moisture content of the test sample should not exceed 5 % in order to avoid test results being noticeably influenced.

NOTE 3—There is no single method for determining the moisture content or for drying the sample. ASTM lists many methods for moisture determination in the *Annual Book of ASTM Standards*. Sample drying is equally complex due to the presence of volatiles, lack of or varying porosity such as coal (see Test Methods D 3173 and D 3175), and sensitivity of the sample to heat. Therefore, each must be dried in a manner that will not modify or destroy the integrity of the sample. Hygroscopic materials must be desiccated.

9. Calibration and Standardization

9.1 Calibration of the air dispersion system should be made to establish proper air flow into the dispersion cup and combustion bomb. A cylindrical calibration chamber as detailed in Fig. A1.13 is secured to the combustion chamber base after setting the mushroom four turns counterclockwise from its closed position. A pressure transducer is connected to the calibration chamber. The air (100 psig, 690 kPa) in the dispersion reservoir is then released and a pressure-time record of the event is obtained from the appropriate measuring equipment. The maximum pressure and rate of pressure rise determined from this record should be within the following limits:

9.1.1 *Maximum Pressure:* 25 ± 2 psig (172 ± 14 kPa)

9.1.2 *Maximum Rate of Pressure Rise:* 975 ± 50 psi/s (6.72 ± 0.34 MPa/s).

9.2 A standardization of the equipment before starting the testing and at the end of the day with 0.75 oz/ft^3 (kg/m^3) of lycopodium is necessary. The test equipment must read a pressure of 100 ± 12 psig (690 ± 83 kPa) and rate of $6300 \text{ psi/s} \pm 20$ % before using.

10. Procedure

10.1 Separate the steel combustion chamber from the dispersion cup base. Clear the dispersion system with several blasts of air. Remove the spark electrodes and insulators from the tube and dry clean them with sandpaper, steel wool, emery cloth, or similar material. Recheck the electrodes and repoint as necessary. Clean the inside of the tube with a wire brush or similar device and remove the loosened residue from the preceding test with a blast of high-pressure air or a vacuum cleaner. Thoroughly clean the dispersion cup, mushroom, and pressure transducer.

10.2 Remove the mushroom and check the mushroom insert (Fig. A1.7) making sure it is flush with the top of the air dispersion cup (A1.6). Reinsert the mushroom by turning it clockwise until the cap is snug against the dispersion cup; then turn the mushroom counterclockwise four complete turns.

10.3 Spread a weighed amount of dust into a uniformly thin layer around the bottom of the dispersion cup. Determine concentration by dividing the weight of dust used by the volume of the steel combustion chamber 75 in.³ (0.00123 m³). Explosion tests are normally made at calculated dust concentrations of 0.1, 0.2, 0.5, 1.0, and 2.0 oz/ft³ (or kg/m³).

NOTE 4—To convert gram weight per 75 in.³ to ounces per cubic feet multiply by 0.813.

10.4 Secure the electrodes in the steel combustion chamber and adjust to a 1/4-in. (6.4-mm) gap.

10.5 Place the O-ring on top of the dispersion cup, and lock the steel combustion chamber in place with the hinged bolts.

10.6 Secure the O-ring and top assembly to the combustion chamber by hand-tightening the locking ring handle.

10.7 Adjust the air dispersing pressure in the 3-in.³ (0.00005-m³) reservoir to 100 psig (690 kPa).

10.8 Ensure that the dispersion system is airtight.

10.9 Attach the electrical source to the electrodes and set the desired recorder speed.

10.10 Put shield in place.

10.11 Actuate the firing circuit to conduct the test (see A1.6 for a description of the sequence of events following activation of the firing circuit).

11. Calculation

11.1 A pressure versus time trace for an explosion is typically of the form given in Fig. 2, from which (1) maximum pressure and (2) maximum rate of pressure rise can be deduced.

11.2 The data points constituting the above curve can be captured using high-speed analog to digital data capture techniques and then the logged data can be analyzed.

11.3 It is important that the captured waveform is free from noise and spikes which could cause errors during the analysis. Filtering techniques in the data capture hardware should be employed and additionally some software smoothing of the data can be undertaken.

12. Report

12.1 Report the following information:

12.1.1 Complete identification of the material tested, including source, code numbers, forms, color, previous history.

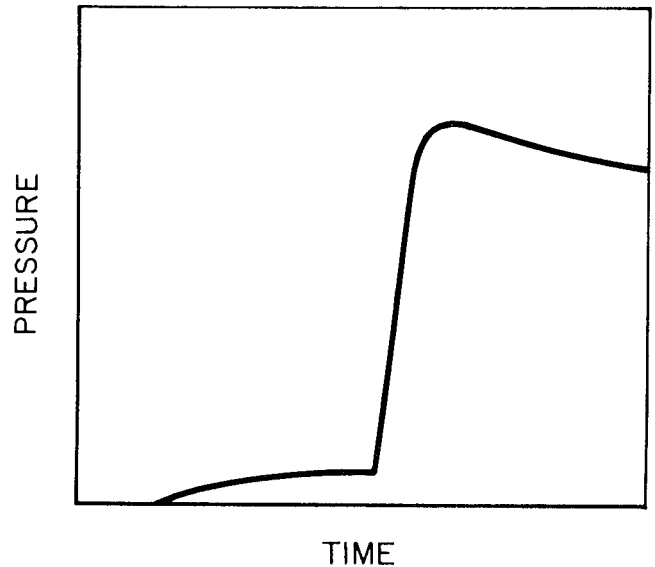

FIG. 2 Pressure Versus Time—Data Analysis

12.1.2 Size distribution (sieve analysis) of the sample as received and as tested.

12.1.3 Moisture content of the as-received and as-tested material.

12.1.4 Maximum pressure for all concentrations and particle sizes tested. Curves showing these data may also be included (see Fig. 3).

13. Precision

13.1 The following criteria should be used for judging the acceptability of results.

13.1.1 *Maximum Pressure:*

13.1.1.1 *Repeatability*—The average of duplicate tests should be considered suspect if they differ by more than 20 %.

13.1.1.2 *Reproducibility*—The average of duplicate tests obtained by each of several laboratories should be considered suspect if they differ by more than 22 %.

NOTE 5—Precision is based on lycopodium reported in ASTM. Other materials may give results outside the above criteria.

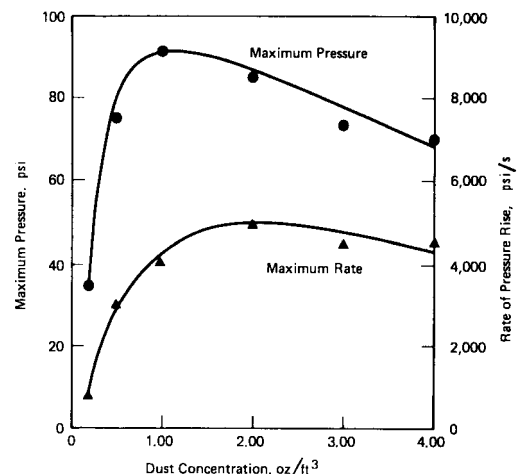

FIG. 3 Maximum Pressure and Rates of Pressure Rise Developed by Explosions of Zirconium Dust in the Hartmann Equipment

14. Keywords

14.1 dust explosion; dust ignition

ANNEXES

(Mandatory Information)

A1. METHOD OF OPERATION OF HARTMANN EQUIPMENT AND DETAILED DRAWINGS

A1.1 Fig. 1 is a schematic of the test apparatus and associated electronic instrumentation. Detailed constructional drawings of each part of the apparatus are shown in Figs. A1.1-A1.13. Part numbers and the figure for the drawings of each part are listed in Table A1.1. To serve as a guide, auxiliary

A1.3.1 The maximum pressure that can be developed in the closed combustion tube from the introduction of the dispersing air is 6.5 psig (45 kPa). Due to the rapid development of the explosion and action of the check valve, the pressure from the dispersing air at the time of ignition is normally 2 to 3 psig (14

TABLE A1.1 Listing of Constructional Drawings for the Hartmann Apparatus

NOTE 1—Make combustion chamber base, six of one piece.

NOTE 2—Combustion chamber assembly, Parts 1, 12, 16, and 6, may be chromium-plated inside and outside except threads of Parts 12 and 16.

NOTE 3—All sliding fits shall be Class 3 medium fit ASA classification of fits. Nominal allowances are indicated.

Fig. No.	Part No.	Nomenclature	Number Required	Material	To Fit Part No.	Method of Assembling
Fig. A1.1	1	Hartmann combustion chamber	1	Seamless carbon mechanical steel tubing
Fig. A1.2	...	Hartmann base support and air control system	1	...	1	...
Fig. A1.3	2	Pressure transducer adapter ring	1	brass	1	slide fit
Fig. A1.3	3	Locking ring	1	brass	1	12 threads per inch
Fig. A1.3	4	Locking ring handle	3	brass	3	silver solder
Fig. A1.3	5	Electrode holder locknut wrench	1	steel	18	...
Fig. A1.4	6	Combustion chamber base	1	steel	1	12 threads per inch
Fig. A1.5	7	Holding lug screws	4	hardened steel	8	1/4-20 thread
Fig. A1.5	8	Holding lug base	4	steel	10	slide fit
Fig. A1.6	9A	Dispersion cup	1	brass	6	slide fit
Fig. A1.7	9B	Mushroom	1	brass	9C	2-56 thread
Fig. A1.7	9C	Mushroom insert	1	brass	9A	snug fit
Fig. A1.8	10	Dispersion cup base	1	brass	9A	6-32 screws
Fig. A1.2	11	Base support	1	aluminum	10	8-32 screws
Fig. A1.9	12	Viewing port	2	brass	1	silver solder
Fig. A1.9	13	Viewing port adapter	2	brass	12	14 threads per inch
Fig. A1.9	14	Viewing window	2	glass	13	Loose slide fit
Fig. A1.10	15	Viewing window lock screw	2	brass	13	16 threads per inch
Fig. A1.10	16	Electrode lug holder	2	brass	1	silver solder
Fig. A1.11	17	Internal electrode holder	2	TFE-fluorocarbon	16	slide fit
Fig. A1.11	18	Internal electrode holder lock nut	2	brass	16	18 threads per inch
Fig. A1.12	19	External electrode holder	2	TFE-fluorocarbon	17	28 threads per inch
Fig. A1.12	20	50-cm ³ tank	1	brass	11	8-32 screws
Fig. A1.13	...	Calibrating chamber (dispersion system)	1	steel	6	...

electronic equipment shown in Fig. 1 can be found in Annex A2.

A1.2 The steel combustion chamber is a vertically mounted, 2¾ -in. (70-mm) diameter, 12-in. (304-mm) long, closed steel tube. It is attached to a metal base and dispersion cup by hinged bolts. The upper portion of the dispersion cup is nearly hemispherical in shape. Air flows into the chamber and impinges on a mushroom-shaped deflector in the bottom of the dispersion cup. Total volume of the combustion chamber is 75 in.³ (0.00123 m³)

A1.3 Dust dispersion is obtained by a single blast of air from a 3-in.³ (0.00005-m³) reservoir that is pressurized to 100 psig (690 kPa). Dispersing air is controlled by a ½-in. (12.7-mm) full port, electrically operated solenoid valve.

to 21 kPa).

A1.4 Ignition of the dust cloud is produced by passing a continuous spark between pointed electrodes (1/16)-in., (1.59-mm) diameter tungsten drill rod) adjusted to a gap length of ¼ in. (6.35 mm) at the axis of the Hartmann tube. The electrodes are centered 4½ in. (114.3 mm) above the base of the Hartmann tube. The power for the igniting spark is obtained from a luminous tube transformer having a rated 115-V input and a 12 000-V secondary.

A1.5 The explosion pressure is sensed by an electronic transducer which sends a signal to an amplifier and recording equipment. Pressure as a function of time is recorded on an oscillograph by a light-beam galvanometer or equivalent recording means; pressure and rate of pressure rise developed by

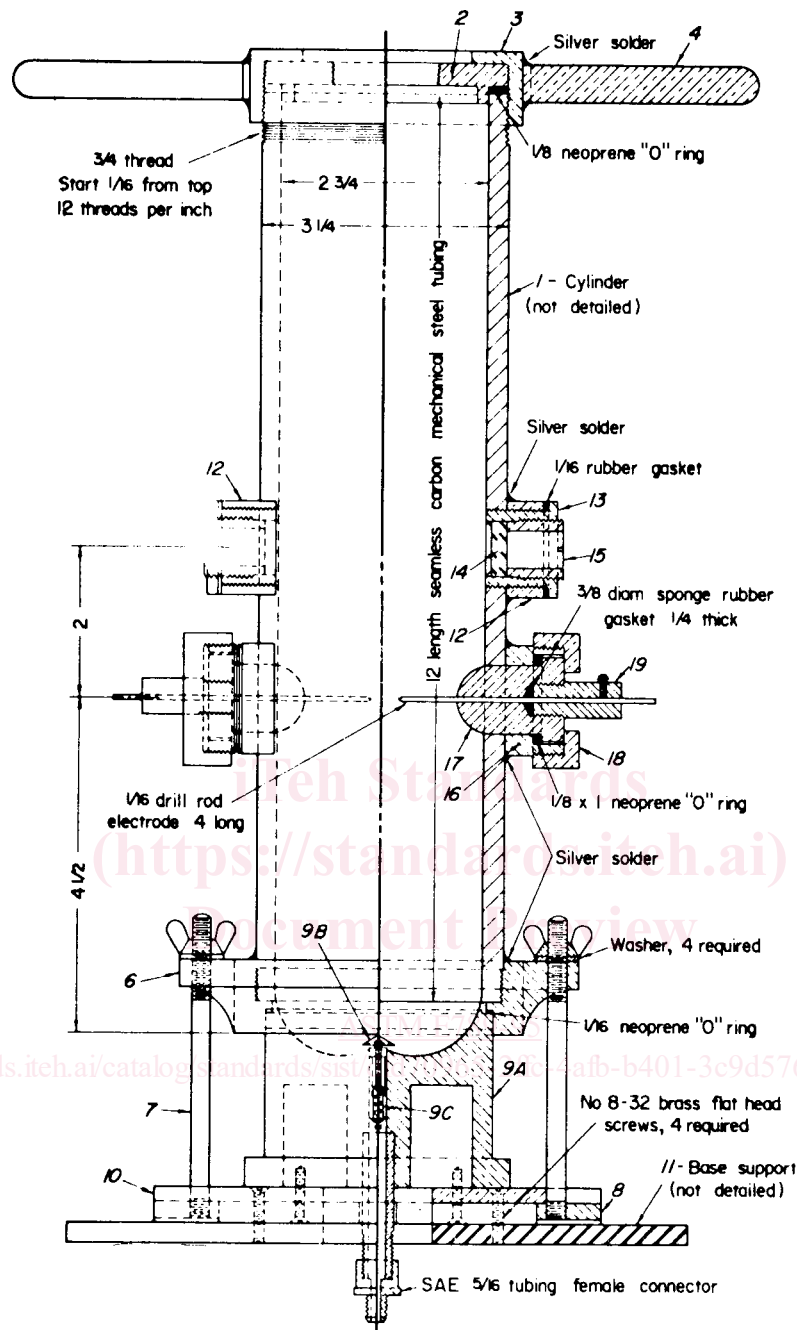

NOTE 1—See Table A1.1 for description of part numbers.

NOTE 2—All dimensions are in inches (1 in. = 25.4 mm).

FIG. A1.1 Harmann Combustion Chamber

the explosion are determined from pressure-time records (see Fig. 3).

A1.6 Initiation of the firing circuit for the Hartmann equipment is controlled by a timer. The sequence of events begins by producing a continuous spark across the tungsten electrodes and then operates the solenoid valve to cause the

dust to disperse approximately 150 ms later. A pressure-time record of the dust explosion test is simultaneously started upon initiation of the firing circuit. If an oscillograph is used, the paper timing must be checked for accuracy and consistency; the paper must be started 1 to 2 s before dispersion.

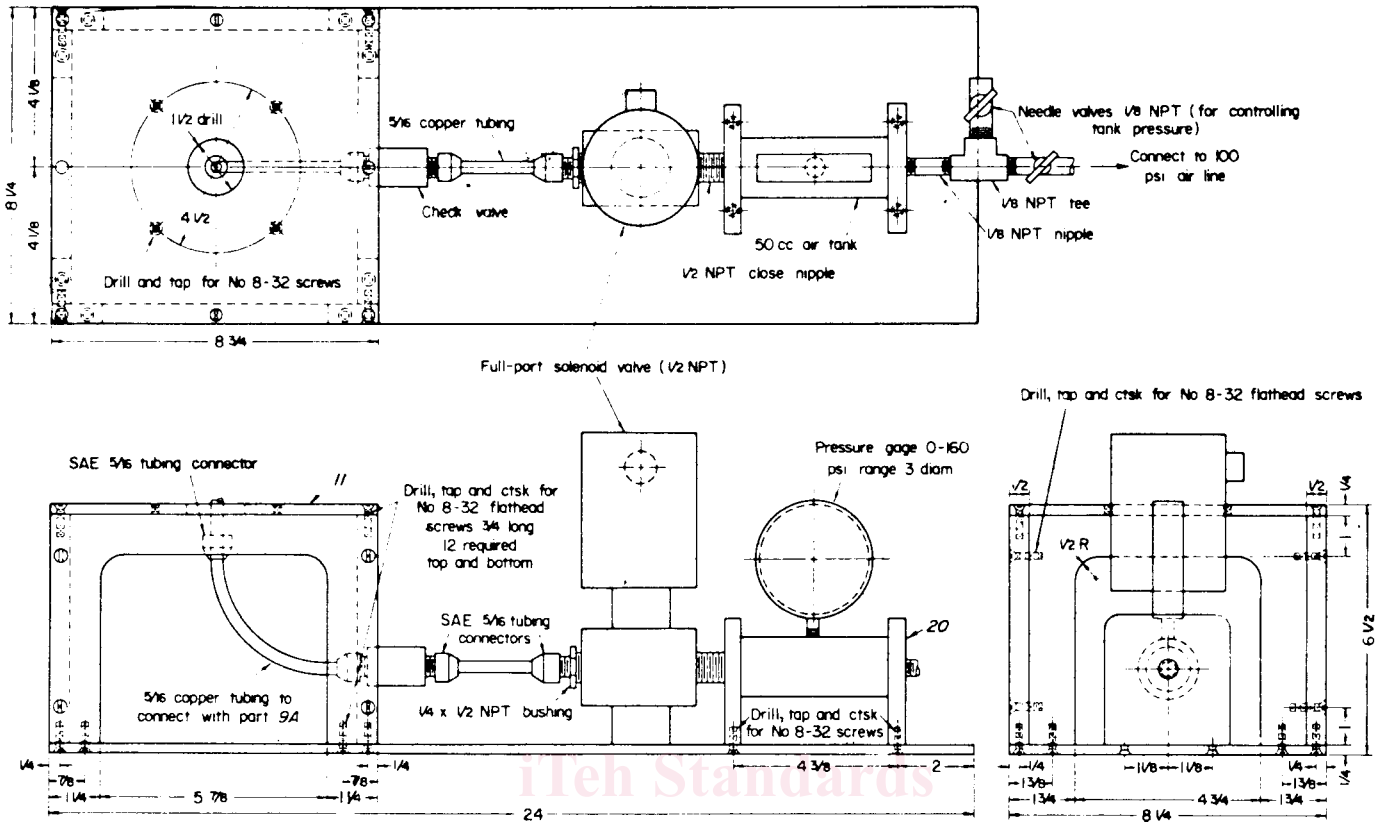

NOTE 1—See Table A1.1 for description of part numbers.
 NOTE 2—All dimensions are in inches (1 in. = 25.4 mm).

FIG. A1.2 Hartmann Base Support and Air Control System

ASTM E789-95

<https://standards.iteh.ai/catalog/standards/sist/dfd70965-2ffc-4afb-b401-3c9d576c1615/astm-e789-95>