



SLOVENSKI STANDARD
SIST ISO 11001-2:1995
01-september-1995

Traktorji in orodja za kmetijsko rabo -- Tri točkasti krmilni sklopni mehanizmi -- Del 2: A-
okvirni sklopni mehanizmi

Agricultural wheeled tractors and implements -- Three-point hitch couplers -- Part 2: A-
frame coupler

iTeh STANDARD PREVIEW

Tracteurs agricoles à roues et instruments -- Coupleurs rapides trois points -- Partie 2:
Coupleur par cadre en A

[SIST ISO 11001-2:1995](https://standards.iteh.ai/catalog/standards/sist/d937eb8-90be-4f93-8f59-cd9c21564aa/sist-iso-11001-2-1995)

Ta slovenski standard je istoveten z: **ISO 11001-2:1993**

ICS:

65.060.01	Kmetijski stroji in oprema na splošno	Agricultural machines and equipment in general
-----------	---------------------------------------	--

SIST ISO 11001-2:1995

en

iTeh STANDARD PREVIEW
(standards.iteh.ai)

[SIST ISO 11001-2:1995](https://standards.iteh.ai/catalog/standards/sist/d1937eb8-90be-4f93-8f59-cd9c21f364aa/sist-iso-11001-2-1995)

<https://standards.iteh.ai/catalog/standards/sist/d1937eb8-90be-4f93-8f59-cd9c21f364aa/sist-iso-11001-2-1995>

INTERNATIONAL
STANDARD

ISO
11001-2

First edition
1993-10-01

**Agricultural wheeled tractors and
implements — Three-point hitch
couplers —**

Part 2:
A-frame coupler

[SIST ISO 11001-2:1995](https://standards.iteh.ai/catalog/standards/sist-11001-2-1995)

<https://standards.iteh.ai/catalog/standards/sist-11001-2-1995> Tracteurs agricoles à roues et instruments — Coupleurs rapides trois points —

Partie 2: Coupleur par cadre en A



Reference number
ISO 11001-2:1993(E)

Foreword

ISO (the International Organization for Standardization) is a worldwide federation of national standards bodies (ISO member bodies). The work of preparing International Standards is normally carried out through ISO technical committees. Each member body interested in a subject for which a technical committee has been established has the right to be represented on that committee. International organizations, governmental and non-governmental, in liaison with ISO, also take part in the work. ISO collaborates closely with the International Electrotechnical Commission (IEC) on all matters of electrotechnical standardization.

Draft International Standards adopted by the technical committees are circulated to the member bodies for voting. Publication as an International Standard requires approval by at least 75 % of the member bodies casting a vote.

International Standard ISO 11001-2 was prepared by Technical Committee ISO/TC 23, *Tractors and machinery for agriculture and forestry*, Sub-Committee SC 4, *Tractors*.

<https://standards.iteh.ai/catalog/standards/sist/d1937eb8-90be-4f93-8f59->

ISO 11001 consists of the following parts, under the general title *Agricultural wheeled tractors and implements — Three-point hitch couplers*:

- Part 1: *U-frame coupler*
- Part 2: *A-frame coupler*
- Part 3: *Link coupler*
- Part 4: *Bar coupler*

© ISO 1993

All rights reserved. No part of this publication may be reproduced or utilized in any form or by any means, electronic or mechanical, including photocopying and microfilm, without permission in writing from the publisher.

International Organization for Standardization
Case Postale 56 • CH-1211 Genève 20 • Switzerland

Printed in Switzerland

Agricultural wheeled tractors and implements — Three-point hitch couplers —

Part 2: A-frame coupler

iTeh STANDARD PREVIEW (standards.iteh.ai)

1 Scope

This part of ISO 11001 specifies the essential dimensions for the attachment of three-point hitch implements to agricultural wheeled tractors equipped with a three-point free link hitch according to ISO 730-1 or ISO 8759-2, and an A-frame hitch coupler.

NOTE 1 In general the dimensions associated with the tractor and the implement for use with hitch couplers are the same as those for the three-point linkage specified in ISO 730-1 or ISO 8759-2, and those for the clearance zone specified in ISO 2332¹⁾.

The three-point hitch coupler systems constitute a special method of implement mounting. The hitch couplers are an additional component located between the three-point linkage and the implement, making it possible to hitch and unhitch from the operator's seat. Due to the special construction and function of hitch couplers, it may be necessary to vary the length of the links indicated in the referenced standards.

This part of ISO 11001 applies to category 2 of agricultural wheeled tractors as defined in ISO 730-1.

2 Normative references

The following standards contain provisions which, through reference in this text, constitute provisions of this part of ISO 11001. At the time of publication, the editions indicated were valid. All standards are subject to revision, and parties to agreements based on this part of ISO 11001 are encouraged to investigate the possibility of applying the most recent editions of the standards indicated below. Members of IEC and ISO maintain registers of currently valid International Standards.

ISO 730-1:1990, *Agricultural wheeled tractors — Rear-mounted three-point linkage — Part 1: Categories 1, 2 and 3.*

ISO 8759-2:1985, *Agricultural wheeled tractors — Front-mounted linkage and power take-off — Part 2: Front linkage.*

1) ISO 2332:1983, *Agricultural tractors and machinery — Connections — Clearance zone for the three-point linkage of implements.*

3 Principle of frame coupler system

A frame coupler system is a one-phase implement coupler where the three-point linkage of the tractor (see ISO 730-1 or ISO 8759-2) is fitted with an A-frame and the implement has the frame incorporated into the mast. Hitching and unhitching can be carried out from the tractor operator's seat (see figure 1).

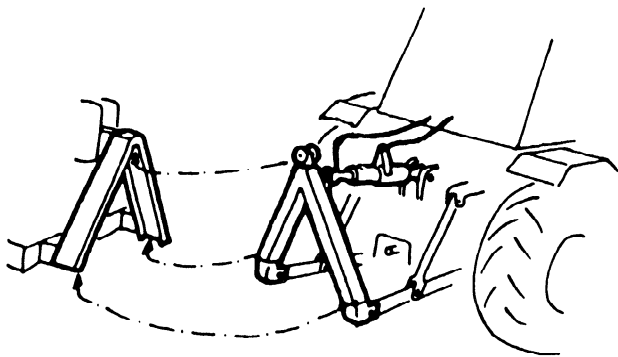

Figure 1 — Principle of A-frame coupler

4 Dimensions

Dimensions shall comply with figures 2 and 3.

5 Requirements associated with implement

5.1 Clearance zones

Clearance zones shall comply with figure 3.

The necessary clearance zones and the height positions of the mast for executing hitching and unhitching are indicated by a dash-point line.

5.2 Locking device

A positive latch shall be provided to prevent unintentional separation of the implement.

iTeh STANDARD PREVIEW
(standards.iteh.ai)

SIST ISO 11001-2:1995

<https://standards.iteh.ai/catalog/standards/sist/df937eb8-90be-4f93-8f59-cd9c21f364aa/sist-iso-11001-2-1995>

Dimensions in millimetres

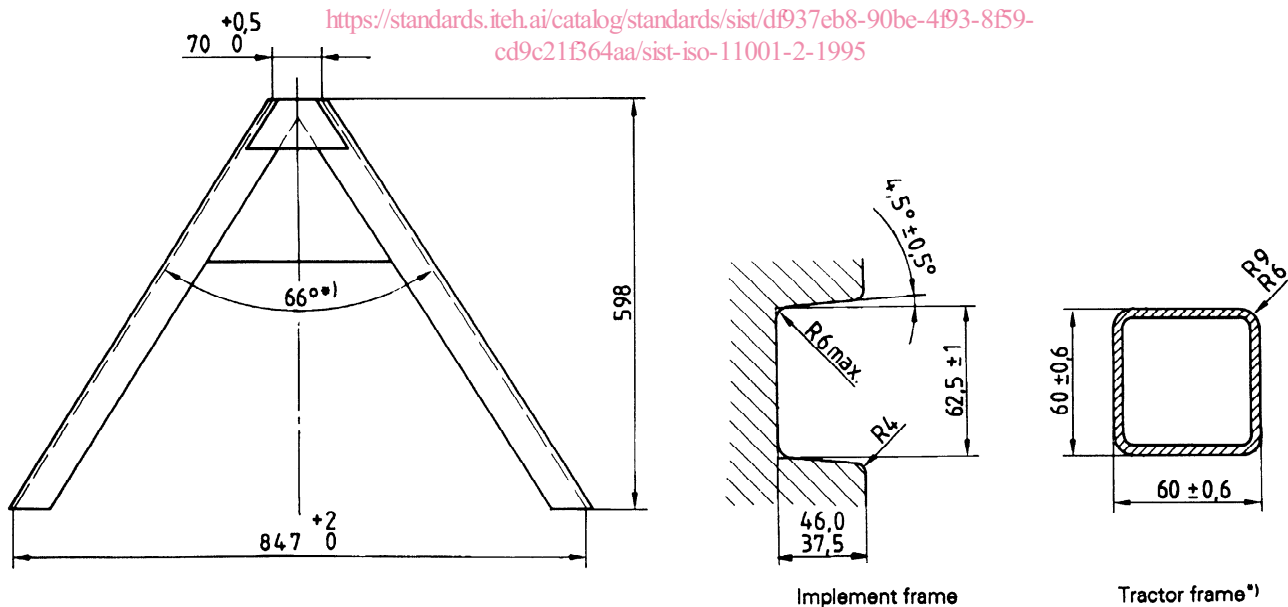

*) For information only.

Figure 2 — Dimensions for coupler associated with implement

Dimensions in millimetres
General tolerance: $\pm 0,1$

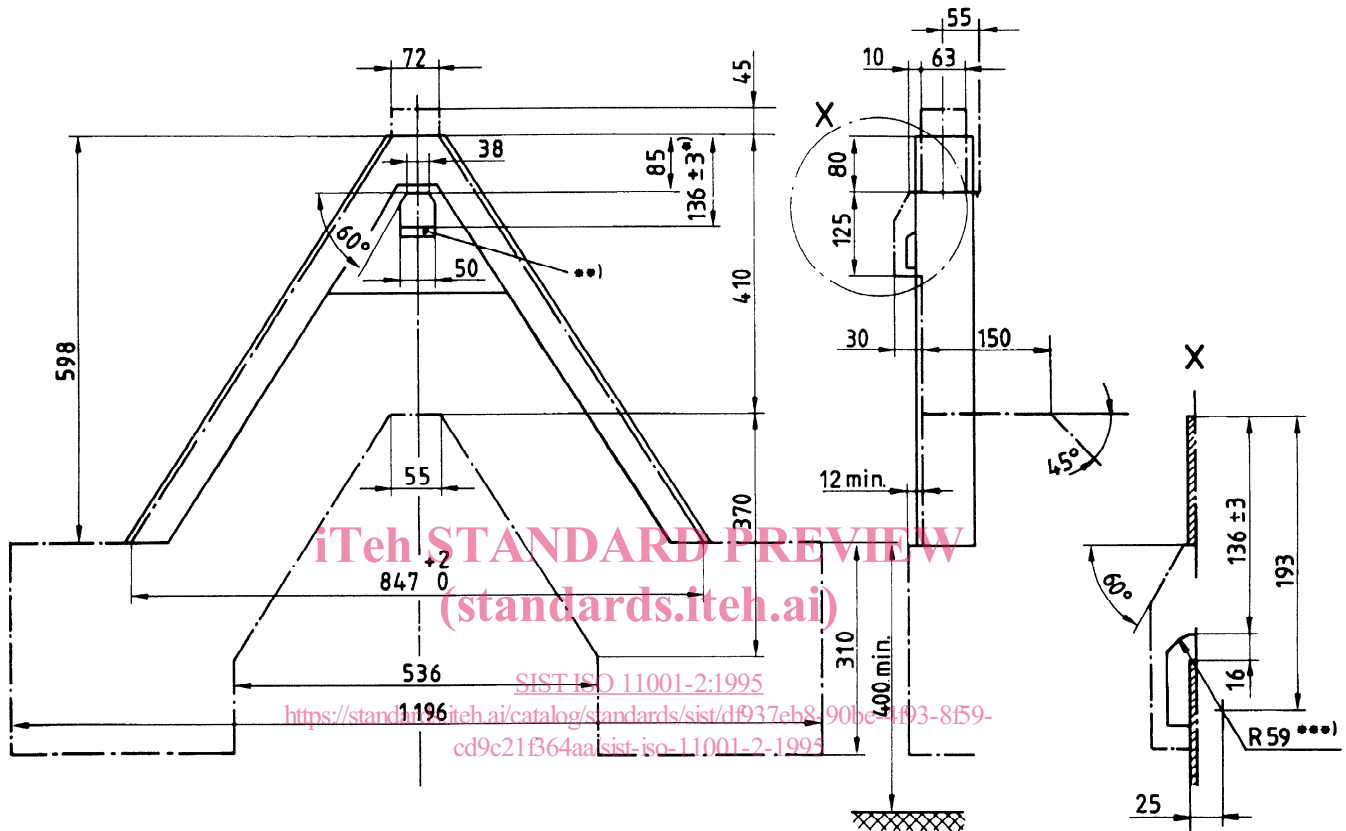

*) See detail X.

***) Adjustable lip to maintain dimension 136 mm.

***) Path of locking device.

Figure 3 — Dimensions and clearance zone for implement frame and locking device