



## Standard Specification for ASTM Thermometers<sup>1</sup>

This standard is issued under the fixed designation E 1; the number immediately following the designation indicates the year of original adoption or, in the case of revision, the year of last revision. A number in parentheses indicates the year of last reapproval. A superscript epsilon (ε) indicates an editorial change since the last revision or reapproval.

*This standard has been approved for use by agencies of the Department of Defense.*

### 1. Scope

1.1 This specification covers liquid-in-glass thermometers graduated in Celsius (centigrade) or Fahrenheit degrees which are frequently specified in methods of ASTM. The various thermometers covered are listed in Table 1. The designation of an IP number in Table 1 indicates, where appearing, that the thermometer specification has been jointly agreed upon by the British Institute of Petroleum (IP) and ASTM.

1.2 This specification also covers adjustable-range enclosed-scale thermometers, graduated in Celsius (centigrade) degrees, which are specified in methods of ASTM.

1.3 The enclosed-scale thermometers are commonly called Beckmann thermometers. They are suitable for measuring small temperature differences not exceeding 6 °C within a larger range of temperature. The thermometers are unsuitable for measuring Celsius- or kelvin-scale temperatures unless they have been compared with standard instruments immediately before use.

1.4 An alphabetic list of the ASTM Thermometers included in this standard is given in Table 2.

1.5 A list of ASTM Thermometers is given in Table 3 to facilitate selection according to temperature range, immersion, and scale-error requirements.

NOTE 1—For a listing of thermometers recommended for general laboratory use, the Scientific Apparatus Makers Assn. Specifications for General Purpose Glass Laboratory Thermometers may be consulted.<sup>2</sup>

NOTE 2—It has been found by experience that these ASTM Thermometers, although developed in general for specific tests, may also be found suitable for other applications, thus precluding the need for new thermometer specifications differing in only minor features.

### 2. Referenced Documents

#### 2.1 ASTM Standards:

E 77 Test Method for Inspection and Verification of Thermometers<sup>3</sup>

E 344 Terminology Relating to Thermometry and Hydrometry<sup>3</sup>

<sup>1</sup> This specification is under the jurisdiction of ASTM Committee E-20 on Temperature Measurement and is the direct responsibility of Subcommittee E20.05 on Liquid-in-Glass Thermometers and Hydrometers.

Current edition approved Nov. 10, 1998. Published March 1999. Originally published as E 1 – 39 T. Last previous edition E 1 – 95.

<sup>2</sup> Available from SAMA Group of Assocs., 225 Reinekers, Ste. 625, Alexandria, VA 23314.

<sup>3</sup> *Annual Book of ASTM Standards*, Vol 14.03.

### 3. Terminology

3.1 *Definitions*—The definitions given in Terminology E 344 apply.

3.2 *Definitions of Terms Specific to This Standard:*

3.2.1 *adjusting device, n*—a section of the instrument used to adjust the amount of mercury in the bulb and main capillary to that needed for the intended temperature interval.

3.2.2 *bulb length, n*—the distance from the bottom of the bulb to the junction of the bulb and the stem tubing.

3.2.3 *contraction chamber, n*—an enlargement of the capillary, that will appear below the main scale or between the main scale and the auxiliary scale, which serves to reduce its length or to prevent contraction of the liquid column into the bulb.

3.2.4 *diameter, n*—the largest outside dimension of the glass as measured with a ring gage.

3.2.5 *expansion chamber, n*—an enlargement at the top of the capillary to provide protection against breakage caused by excessive gas pressure.

3.2.6 *interval error, n*—the deviation of the nominal value of a temperature interval from its true value; either for the total range (total interval) or for a part of the range (partial interval).

3.2.7 *saddle, n*—the bottom support of the enclosed scale.

3.2.8 *setting temperature, n*—the temperature that yields a reading of zero on the main scale for a given adjustment of the amount of mercury in the bulb and main capillary.

3.2.9 *top of the thermometer, n*—the top of the finished instrument.

3.2.10 *total length, n*—the distance from the bottom of the bulb to the top of the finished thermometer, including any special finish at the top.

3.2.11 Other descriptions of terms shall be in accordance with the Terminology section of Test Method E 77.

### Part A—Solid-Stem Thermometers

### 4. Specifications

4.1 The individual thermometers shall conform to the detailed specifications given in Table 1 and to the general requirements specified in Sections 5-13.

NOTE 3—Such thermometers manufactured prior to the adoption of the specifications will retain the same official status as those meeting current specifications.

NOTE 4—Encapsulating thermometers will change their performance

and physical characteristics, including, but not limited to, response time, accuracy, and physical dimensions. Therefore, under no circumstances should an encapsulated or otherwise modified ASTM thermometer be used in performing tests that specify the use of an ASTM thermometer.

**5. Type**

5.1 Each thermometer shall be of the mercury-in-glass type, unless otherwise specified in Table 1. The filling above the liquid shall be nitrogen or other suitable inert gas.

**6. Stem**

6.1 *Stem*—The stem shall be made of suitable thermometer tubing and shall have a plain front and enamel back, unless otherwise specified in Table 1.

6.2 *Top Finish*—The top of all thermometers specified in Table 1 shall have a plain rounded finish, except the following which shall have the top finish indicated below (unless indicated as optional):

6.2.1 *Glass Button Finish:*

Thermometers 23C, 24C, and 25C

6.2.2 *Special Finish:*

6.2.2.1 Suitable for assembly in a standard 304.8-mm (12-in.) non-sparking metal armor with open face; in a cup case assembly; or in a flushing case assembly:

Thermometers 58C, 58F, 59C, 59F, 60C, 60F, 97C, 97F, 98C, and 98F

6.2.2.2 Suitable for assembly in a 12-in. non-sparking metal armor with open face:

Thermometer 99F

6.2.3 *Ring Top* (optional only)—Thermometers 11C and 11F.

**7. Bulb**

7.1 The bulb shall be made of glass having a viscosity of at least  $10^{14.6}$  poises at 490 °C (914 °F) and at least  $10^{13.4}$  poises at 520 °C (968 °F).

NOTE 5—Thermometers made with bulb glasses having properties close to these minimum requirements should not be subjected to temperatures above 405 °C (760 °F) or be continuously exposed to temperatures above 370 °C (700 °F).

**8. Capillary Clearances**

8.1 In order that a thermometer scale be usable over its entire range, graduation marks must not be placed too close to any enlargement in the capillary. Insufficient immersion of the mercury in the main bulb or capillary enlargement, graduation marks placed over parts of the capillary that have been changed by manufacturing operations, or graduations so close to the top of the thermometer that excessive gas pressure results when the mercury is raised to this level, may lead to appreciable errors. The following distances between graduations and the bulb and between graduations and enlargements in the bore are considered as minimum limits for thermometers acceptable for certification.

8.1.1 Due to a change in the method used for scale placement, it is possible to manufacture thermometers that comply with the specifications given in Table 1, but do not meet the requirements for capillary clearances given below. In any case,

the distances given in this section are the governing factor. Under no circumstances should the scales on thermometers be placed closer than these minimum distances:

8.1.2 A 13-mm length of unchanged capillary between the bulb and the immersion line or lowest graduation, if the graduation is not above 100 °C (212 °F); a 30-mm length if the graduation is above 100 °C (212 °F).

8.1.3 A 5-mm length of unchanged capillary between an enlargement and the graduation next below, except at the top of the thermometer.

8.1.4 A 10-mm length of unchanged capillary between an enlargement, other than the bulb, and the immersion line or the graduation next above, if the graduation is not above 100 °C (212 °F); a 30-mm length if the graduation is above 100 °C (212 °F).

8.1.5 A 10-mm length of unchanged capillary above the highest graduation, if there is an expansion chamber at the top of the thermometer; a 30-mm length if there is no expansion chamber. For the purposes of this requirement, “an expansion chamber” is interpreted as an enlargement at the top end of the capillary bore which shall have a capacity equivalent to not less than 20 mm of unchanged capillary.

**9. Graduations and Inscriptions**

9.1 All graduation lines, figures, and letters shall be clearly defined, suitably colored, and permanent.

9.1.1 A suitably etched thermometer with the etched lines

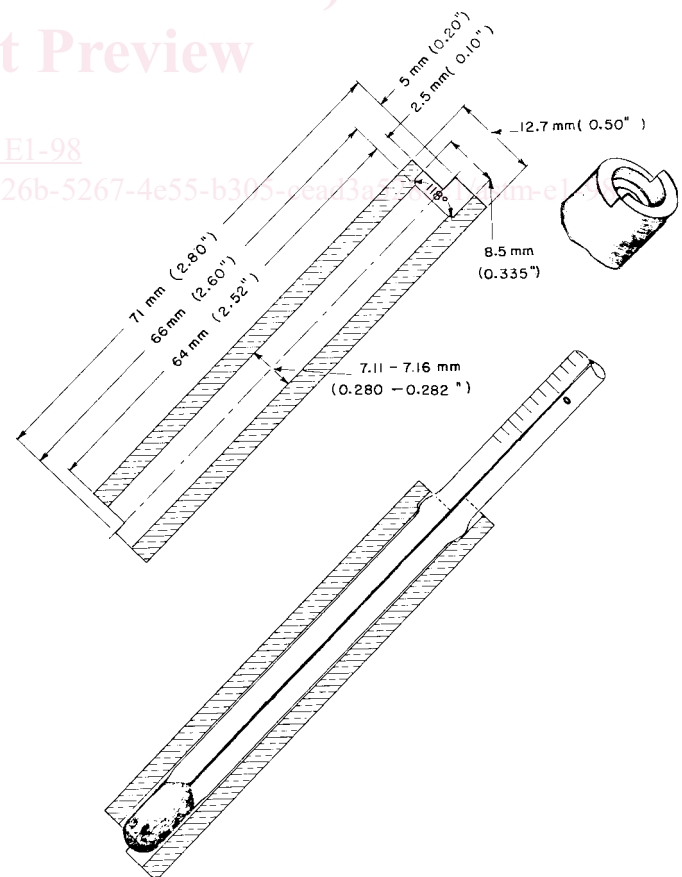

**FIG. 1 Test Gage for Checking Enlargements on Thermometers 9C, 9F, 10C, 10F, 57C, 57F, 88C, and 88F**

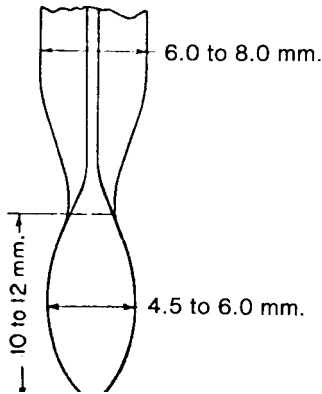

FIG. 2 Bulb of ASTM Congealing Point Thermometers 54C and 54F

and figures filled with a pigment shall be considered permanently marked provided it passes the test for permanency of pigment in Test Method E 77.

9.2 *Graduation Lines*—All graduation lines shall be straight, of uniform width, and perpendicular to the axis of the thermometer. The width of the graduation lines shall be as follows:

9.2.1 *Group 1*— Maximum line width 0.10 mm:

Thermometers 14C, 14F, 26C, 28C, 28F, 29C, 29F, 30F, 33C, 33F, 34C, 34F, 35C, 35F, 44C, 44F, 45C, 45F, 46C, 46F, 47C, 47F, 48C, 48F, 50F, 51F, 52C, 56C, 56F, 62C, 62F, 63C, 63F, 64C, 64F, 65C, 65F, 66C, 66F, 67C, 67F, 68C, 68F, 69C, 69F, 70C, 70F, 72C, 72F, 73C, 73F, 74C, 74F, 89C, 90C, 91C, 92C, 93C, 94C, 95C, 96C, 100C, 101C, 110C, 110F, 111C, 112C, 113C, 113F, 116C, 117C, 118C, 118F, 119C, 119F, 120C, 121C, 126C, 126F, 127C, 128C, 128F, 129C, and 129F.

9.2.2 *Group 2*— Maximum line width 0.15 mm:

Thermometers 1C, 1F, 2C, 2F, 3C, 3F, 5C, 5F, 6C, 6F, 7C, 7F, 8C, 8F, 9C, 9F, 10C, 10F, 11C, 11F, 12C, 12F, 13C, 15C, 15F, 16C, 16F, 17C, 17F, 18C, 18F, 19C, 19F, 20C, 20F, 21C, 21F, 22C, 22F, 23C, 24C, 25C, 36C, 37C, 38C, 39C, 40C, 41C, 42C, 43C, 43F, 49C, 54C, 54F, 61C, 61F, 71C, 71F, 82C, 82F, 83C, 83F, 84C, 84F, 85C, 85F, 86C, 86F, 87C, 87F, 99C, 99F, 102C, 103C, 104C, 105C, 106C, 107C, 108F, 109F, 114C, 122C, 123C, 124C, and 125C.

9.2.3 *Group 3*— Maximum line width 0.20 mm:

Thermometers 27C, 57C, 57F, 58C, 58F, 59C, 59F, 60C, 60F, 75F, 76F, 77F, 78F, 79F, 80F, 81F, 88C, 88F, 97C, 97F, 98C, 98F, 130C, and 130F.

NOTE 6—A maximum line width of 0.10 mm is recommended for thermometers that may be read to fractions of a division, many times with magnifying aids; 0.15 mm for thermometers that may be read to the nearest half division or where the congestion of the scale dictates the use of a scale of moderate fineness; and finally 0.20 mm maximum for thermometers with more open scales usually read to the nearest division, often times under adverse conditions, where a bold graduation is therefore desired.

9.3 *Immersion Line*—On partial immersion thermometers an immersion line shall be permanently marked on the front of the thermometer at the distance above the bottom of the bulb as specified in Table 1 within a tolerance of  $\pm 0.5$  mm, except for Thermometers 82F to 87F.

9.4 *Terminal Numbers*—The terminal number shall be in full when there are one or more numbered graduations between it and the next full number, for example on Thermometer 12C, the terminal numbers would be 100, 1, 102 °C. This rule need not necessarily be followed for:

9.4.1 *Saybolt Viscosity Thermometers:*

17C, 17F, 18C, 18F, 19C, 19F, 20C, 20F, 21C, 21F, 22C, 22F, 77F, 78F, 79F, 80F, and 81F

9.4.2 *Kinematic Viscosity Thermometers:*

28F, 29F, 30F, 44F, 45F, 46F, 47F, 48F, 72F, 73F, 74F, 110F, 118F, 126F, 128F, and 129F

9.4.3 *Engler Viscosity Thermometers:*

23C, 24C, and 25C

9.4.4 *Precision Thermometers:*

65F, 66F, 67C, 67F, and 68C

9.4.5 *Tank Thermometer:*

97F

9.4.6 *Solidification Point Thermometers:*

100C and 101C

9.4.7 *Reid Vapor Pressure:*

18C and 18F

9.4.8 *Oxidation Stability:*

22C and 22F

9.5 *Scale Below Zero*—When a scale extends both above and below 0 °C or 0 °F, the two parts of the scale shall be differentiated by some means. Examples of suitable means are:

- 9.5.1 Different colors for the two parts of the scale,
- 9.5.2 Different style of numerical characters for the two parts of the scale, and
- 9.5.3 Use of minus signs before appropriate numbers below 0 °C or 0 °F.

10. **Special Inscription**

10.1 The special inscription specified in Table 1 shall be marked on the thermometer in capital letters and arabic numbers without the use of periods. In addition to the special inscription prescribed in Table 1, each thermometer shall be permanently marked with a unique serial number and the manufacturer's tradename or mark.

10.2 *Engraving Date on ASTM Thermometers*—If a thermometer's specification was changed, the year that it was changed is engraved on the back of the thermometer after the ASTM designation. For example, "12C-98."

11. **Permanency of Pigment**

11.1 The test for permanency of pigment shall be performed on any convenient portion of the scale section of the thermometer. The pigment shall not chalk, burn out, or loosen as a result of this test.

12. **Bulb Stability**

12.1 The test for bulb stability shall be made for the following thermometers in the temperature range specified below for 24 h. The scale error after the test shall be within the scale error specified in Table 1.<sup>4</sup> Reference should be made to Test Method E 77.

<sup>4</sup> Observations of a reference point before and after the test give a measure of the degree of bulb stability achieved in manufacture.

ASTM Thermometer Number	Test Temperature Range
3C, 8C, 10C, 11C, 70C	360 to 370°C
3F, 8F, 10F, 11F, 70F	680 to 700°F
2C, 7C, 69C, 107C	280 to 290°C
2F, 7F, 69F	540 to 560 °F

The change in bulb volume in this test shall not exceed 0.7 of the allowable scale error.

### 13. Scale Error

13.1 Thermometers shall be verified and calibrated at the temperatures specified in Table 4.

13.1.1 Scale errors must be within the stated tolerances at the time of purchase. The indications of many high temperature and fractionally graduated thermometers may change with time and continued use, due to minute changes in bulb volume. Periodic reverification of these thermometers, in accordance with procedures set forth in Test Method E 77, is recommended.

13.2 Due to the application requirements for range and construction of the following thermometers, it is not practical to include reference points such as the ice and steam points.

13C, 14C, 14F, 17C, 17F, 18C, 18F, 19C, 19F, 20C, 20F, 21C, 21F, 23C, 24C, 26C, 27C, 38C, 49C, 50F, 51F, 56C, 56F, 76F, 77F, 78F, 79F, 80F, 81F, 83C, 83F, 84C, 84F, 87C, 87F, 91C, 92C, 93C, 96C, 98C, 98F, 100C, 101C, 102C, 103C, 104C, 105C, 106C, 107C, 108F, 109F, 111C, 116C, 117C, 122C, 123C, and 124C

### 14. Case

14.1 Each thermometer shall be supplied in a suitable case on which shall appear the following marking (except when a transparent case is used): the letters "ASTM," the thermometer number (33C, 33F, etc.), and the temperature range.

### 15. Methods of Verification and Calibration

15.1 Thermometers shall be verified and calibrated at the specified immersion in accordance with Test Method E 77.

iTeh Standards  
(<https://standards.iteh.ai>)  
Document Preview

[ASTM E1-98](#)

<https://standards.iteh.ai/catalog/standards/sist/0336926b-5267-4e55-b305-cead3a528ec1/astm-e1-98>

**TABLE 1 Specification for ASTM Thermometers**

All dimensions are in millimeters.

See Table 4 for Verification and Calibration Temperatures.

**Explanatory Notes:**

- A* An expansion chamber is provided for relief of gas pressure to avoid distortion of the bulb at higher temperatures. It is not for the purpose of joining mercury separations and under no circumstances should the thermometer be heated above the highest temperature reading.
- B* Toluene or other suitable liquid colored red with a permanent dye shall be used as the actuating liquid.
- C* Under certain test conditions, the bulb of the thermometer may be 28 °C (50 °F) above the temperature indicated by the thermometer, and at an indicated temperature of 371 °C (700 °F) the temperature of the bulb is approaching a critical range in the glass. It is therefore not desirable to use this thermometer under such conditions at indicated temperatures above 371 °C (700 °F) without checking the ice point.
- D* Longest graduation lines at 155 °C, 160 °C, 162 °C, 164 °C, 165 °C, and 170 °C, with arrows at 162 °C and 164 °C.
- E* The length of the enlargement, and the distance from the bottom of the enlargement to the bottom of the bulb shall be measured with the test gage shown in Fig. 1.
- F* Long, narrow shape.
- G* The test temperature shall be indicated by an arrow whether the graduation corresponding to that point is numbered or not.
- H* Long, narrow shape; mercury shall be in the chamber at 0 °C (32 °F).
- I* The thermometer shall be made to be mounted in a brass ferrule consisting of a tubular bushing 8.0 mm in outside diameter with a flanged head approximately 12 mm in diameter so that the upper extremity of the 8.0 mm diameter is located 90 mm from the bottom of the bulb.
- J* To be marked on the glass stem at least 90 mm from the bottom of the bulb.
- K* Glass button finish, see 6.2.1.
- L* Long, narrow shape; mercury shall be near bottom of the chamber at 0 °C.
- M* For kinematic viscosity thermometers, the ice-point reading shall be taken within 1 h after being at the test temperature for not less than 3 minutes. The ice-point reading shall be expressed to the nearest 0.01 °C or 0.02 °F and applied as explained in Test Method E 77, Section 13.
- N* Thermometers made to these specifications conform also with the requirements for the titer test thermometer of the American Oil Chemists Society and the Association of Official Agricultural Chemists, except for the special inscription.
  - O* Capillary clearances must conform to Section 8.
  - P* Mercury shall be near middle of chamber at 0 °C.
  - Q* The stem may be either the plain front or lens front type. If the thermometer is of the lens front type, the cross section of the stem shall be such that it will pass through an 8-mm ring gage but will not enter a 5-mm slot gage.
  - R* A suitable mercury-thallium alloy shall be used as the actuating liquid.
  - S* The expansion chamber shall be of the long narrow type 10 to 20 mm in length. The length of unchanged capillary between the nearest graduation mark and the expansion chamber shall be not less than 10 mm.
  - T* Mercury shall be near the bottom of the chamber at 0 °C.
  - U* The length of unchanged capillary between the nearest graduation mark and contraction chamber shall be not less than 10 mm.
  - V* Change in correction over any 5 °F interval shall not exceed 0.10 °F.
  - W* Expansion chamber shall be of the long narrow type and there shall be not less than 10 mm of unchanged capillary between the base of the chamber and the top graduation.
  - X* Mercury shall be in the chamber at 32 °F.
  - Y* Over any interval of 2 °C the change in correction shall not exceed 0.02 °C.
  - Z* Over any interval of 4 °F the change in correction shall not exceed 0.05 °F.
- AA* Special finish, see 6.2.2.
- BB* The bulb diameter shall not be more than 0.5 mm greater than the stem.
- CC* The stem shall be of the lens front type. The cross section of the stem shall be such that it will pass through a 8.0-mm ring gage but will not enter a 5.0-mm slot gage. A minor diameter of 4 mm is permissible provided that the major diameter is not less than 7 mm.
- DD* Bulb bottom shall be essentially hemispherical.
- EE* Immersion line shall be omitted.

*FF* For Fahrenheit thermometers, dimension G (length of graduated portion) shall be measured as the length of graduated portion corresponding to the nominal Celsius range.

*GG* The immersion line shall be visible in the case opening after assembly. The immersion shall be measured from the bottom of the bulb rather than from the bottom of the armor. See 6.2.2.

*HH* The stem shall be either the round or lens-front type.

*I* Contraction chamber to be long narrow type.

*J* Over any interval of 1 °C the change in correction shall not exceed 0.01 °C. The correction at the lowest temperature of the nominal range shall not change by more than 0.02 °C immediately after the thermometer has been heated for 15 min at a temperature 30 °C higher, and allowed to cool naturally in air.

*KK* The capillary bore shall be large enough in relation to the bulb to ensure that (without tapping) jumping of the meniscus does not exceed one half of the smallest scale division, when the temperature is rising at a uniform rate not exceeding 0.05 °C/min.

*LL* The thermometer is to be calibrated for 100-mm immersion for the main scale, the ice point is to be calibrated for total immersion.

*MM* Bulb shape ellipsoidal (see Fig. 2).

*NN* This thermometer may be furnished with an optional ring top. See 6.2.3. Addition of a ring top will increase the total length by an amount equal to the outside diameter of the ring.

iTech Standards  
(<https://standards.iteh.ai>)  
Document review

<https://standards.iteh.ai/catalog/standards/sist/0c667066-664e55-b305-ccad3a528ec1/astm-e1-98>

TABLE 1 Continued

ASTM No.	1C-99	1F-99 <sup>FF</sup>	2C-99	2F-99 <sup>FF</sup>	3C-99	3F-99 <sup>FF</sup>
IP No.			62C		73C	
Name						
Reference Fig. No.						
Range	-20 to + 150°C	0 to 302°F	-5 to + 300°C	20 to 580°F	-5 to + 400°C	20 to 760°F <sup>C</sup>
For test at						
A Immersion, mm		76		76		76
Graduations:						
Subdivisions	1°C	2°F	1°C	2°F	1°C	2°F
Long lines at each	5°C	10°F	5°C	10°F	5°C	10°F
Numbers at each	10°C	20°F	10°C	20°F	10°C	20°F
Scale error, max	0.5°C	1°F	1°C	2°F	1°C to 301°C	2°F to 574°F
					1.5°C above	3°F above
					301°C	574°F
Special inscription		ASTM 1C-99 or 1F-99 76 MM IMM		ASTM 2C-99 or 2F-99 76 MM IMM	ASTM 3C-99 or 3F-99 76 MM IMM	
Expansion chamber:						
Permit heating to		200°C				
B Total length, mm		317 to 327		385 to 395		410 to 420
C Stem OD, mm		6.0 to 7.0		6.0 to 7.0		6.0 to 7.5
D Bulb length, mm		19 to 25		10 to 15		10 to 15
E Bulb OD, mm		5.0 to 6.0		5.0 to 6.0		5.0 to 6.0
Scale location:						
Bottom of bulb to line at	0°C	32°F	0°C	32°F	0°C	32°F
F Distance, mm		111 to 118		100 to 110		100 to 110
G Length of graduated portion, mm		170 to 200 <sup>o</sup>		225 to 265 <sup>o</sup>		250 to 290 <sup>o</sup>
Ice-point scale:						
Range						
H Bottom of bulb to ice-point, mm						
Contraction chamber:						
I Distance to bottom, min, mm						
J Distance to top, max, mm						
Stem enlargement:						
K OD, mm						
L Length, mm						
M Distance to bottom, mm						

<sup>A</sup> An expansion chamber is provided for relief of gas pressure to avoid distortion of the bulb at higher temperatures. It is not for the purpose of joining mercury separations and under no circumstances should the thermometer be heated above the highest temperature reading.

<sup>B</sup> Under certain test conditions, the bulb of the thermometer may be 28°C (50°F) above the temperature indicated by the thermometer, and at an indicated temperature of 371°C (700°F) the temperature of the bulb is approaching a critical range in the glass. It is therefore not desirable to use this thermometer under such conditions at indicated temperatures above 371°C (700°F) without checking the ice point.

<sup>C</sup> Capillary clearances shall conform to Section 8.

<sup>FF</sup> For Fahrenheit thermometers, dimension G (length of graduated portion) shall be measured as the length of graduated portion corresponding to the nominal Celsius range.

TABLE 1 Continued

ASTM No.	5C-86	5F-86 <sup>FF</sup>	6C-86	6F-86 <sup>FF</sup>	7C-86	7F-86 <sup>FF</sup>
IP No.	1C		2C	5C		
Name		Cloud and Pour 3		Low Cloud and Pour <sup>B</sup> 3		Low Distillation 4
Reference Fig. No.						
Range	-38 to +50°C	-36 to +120°F	-80 to +20°C	-112 to +70°F	-2 to +300°C	30 to 580°F
For test at		108		76		total
A Immersion, mm						
Graduations:						
Subdivisions	1°C	2°F	1°C	2°F	1°C	2°F
Long lines at each	5°C	10°F	5°C	10°F	5°C	10°F
Numbers at each	10°C	20°F	10°C	20°F	10°C	20°F
Scale error, max	0.5°C	1°F	1°C to -33°C 2°C below -33°C	2°F to -28°F 4°F below -28°F	0.5°C to 150°C 1°C above 150°C	1°F to 300°F 2°F above 300°F
Special inscription		ASTM 5C-86 or 5F-86 108 MM IMM		ASTM 6C-86 or 6F-86 76 MM IMM	ASTM 7C-86 or 7F-86	
Expansion chamber:						
Permit heating to	100°C	212°F	60°C	140°F		<sup>A</sup>
B Total length, mm		225 to 235		225 to 235		380 to 390
C Stem OD, mm		6.0 to 8.0		6.0 to 8.0		6.0 to 8.0
D Bulb length, mm		7 to 10		7 to 10		10 to 15
E Bulb OD, mm		<5.5 and >stem		<5.0 and >stem		<5.0 and >stem
Scale location:						
Bottom of bulb to line at	-38°C	-36°F	-70°C	-94°F	0°C	32°F
F Distance, mm		120 to 130		100 to 120		100 to 110
G Length of graduated portion, mm		65 to 85 <sup>o</sup>		70 to 100 <sup>o</sup>		225 to 255 <sup>o</sup>
Ice-point scale:						
Range						
H Bottom of bulb to ice-point, mm						
Contraction chamber:						
I Distance to bottom, min, mm						
J Distance to top, max, mm						
Stem enlargement:						
K OD, mm						
L Length, mm						
M Distance to bottom, mm						

<sup>A</sup> An expansion chamber is provided for relief of gas pressure to avoid distortion of the bulb at higher temperatures. It is not for the purpose of joining mercury separations and under no circumstances should the thermometer be heated above the highest temperature reading.

<sup>B</sup> Toluene or other suitable liquid colored red with a permanent dye shall be used as the actuating liquid.

<sup>C</sup> Capillary clearances shall conform to Section 8.

<sup>FF</sup> For Fahrenheit thermometers, dimension G (length of graduated portion) shall be measured as the length of graduated portion corresponding to the nominal Celsius range.



TABLE 1 Continued

ASTM No.	8C-86	8F-86 <sup>FF</sup>	9C-86	9F-86 <sup>FF</sup>	10C-86	10F-86 <sup>FF</sup>
IP No.	6C	15C	16C			
Name		High Distillation	Low-Pensky-Martens	High-Pensky-Martens		
Reference Fig. No.		4	5	5		
Range	-2 to +400°C <sup>C</sup>	30 to 760°F <sup>C</sup>	20 to 230°F	90 to 370°C	200 to 700°F	
For test at		total				
A Immersion, mm			57	57		
Graduations:						
Subdivisions	1°C	0.5°C	1°F	2°C	5°F	
Long lines at each	5°C	1°C and 5°C	5°F	10°C	25°F	
Numbers at each	10°C	5°C	10°F	20°C	50°F	
Scale error, max	1°C to 300°C	2°F to 570°F	1°F	1°C to 260°C	2.5°F to 500°F	
	1.5°C above 300°C	3°F above 570°F		2°C above 260°C	3.5°F above 500°F	
Special inscription		ASTM	ASTM	ASTM	ASTM	
		8C-86 or 8F-86	9C-86 or 9F-86	10C-86 or 10F-86		
			57 MM IMM	57 MM IMM		
Expansion chamber:						
Permit heating to		160°C				
B Total length, mm						
C Stem OD, mm			285 to 295	285 to 295		
D Bulb length, mm			6.0 to 7.0	6.0 to 7.0		
E Bulb OD, mm			9 to 13	7 to 10		
Scale location:			<5.5 and >stem	<4.5 and >stem		
Bottom of bulb to line at						
F Distance, mm	0°C	0°C	32°F	90°C	200°F	
G Length of graduated portion, mm			85 to 95	80 to 90		
Ice-point scale:			140 to 175 <sup>O</sup>	145 to 180 <sup>O</sup>		
Range						
H Bottom of bulb to ice-point, mm						
Contraction chamber:						
I Distance to bottom, min, mm						
J Distance to top, max, mm						
Stem enlargement						
K OD, mm			7.5 to 8.5	7.5 to 8.5		
L Length, mm			2.5 to 5.0 <sup>F</sup>	2.5 to 5.0 <sup>F</sup>		
M Distance to bottom, mm			64 to 66	64 to 66		

<sup>A</sup> An expansion chamber is provided for relief of gas pressure to avoid distortion of the bulb at higher temperatures. It is not for the purpose of joining mercury separations and under no circumstances should the thermometer be heated above the highest temperature reading.

<sup>C</sup> Under certain test conditions, the bulb of the thermometer may be 28°C (50°F) above the temperature indicated by the thermometer, and at an indicated temperature of 371°C (700°F) the temperature of the bulb is approaching a critical range in the glass. It is therefore not desirable to use this thermometer under such conditions at indicated temperatures above 371°C (700°F) without checking the ice point.

<sup>E</sup> The length of the enlargement, and the distance from the bottom of the enlargement to the bottom of the bulb shall be measured with the test gage shown in Fig. 1.

<sup>O</sup> Capillary clearances shall conform to Section 8.

<sup>FF</sup> For Fahrenheit thermometers, dimension G (length of graduated portion) shall be measured as the length of graduated portion corresponding to the nominal Celsius range.

TABLE 1 Continued

	ASTM No.	11C-86	11F-86 <sup>FF</sup>	64C	12C-86	64F	12F-86 <sup>FF</sup>	13C-86
IP No.		28C						47C
Name								Loss on Heat
Reference Fig. No.								9
Range		-6 to +400°C <sup>C</sup>	20 to 760°F <sup>C</sup>	-20 to +102°C		-5 to +215°F		155 to 170°C
For test at								total
A	Immersion, mm		25					0.5°C
	Graduations:							1°C <sup>D</sup>
	Subdivisions	2°C	5°F	0.2°C		0.5°F		155°C, 160°C, 165°C,
	Long lines at each	10°C	10°F	1°C		1°F		170°C
	Numbers at each	20°C	20°F	2°C		5°F		0.5°C
	Scale error, max	2°C to 260°C	5°F to 500°F	0.15°C		0.25°F		ASTM
	Special inscription	4°C above 260°C	7°F above 500°F					13C-86
			ASTM					
			11C-86 or 11F-86					
			25 MM IMM					
	Expansion chamber:							
	Permit heating to							
B	Total length, mm		<sup>A</sup>	150°C		300°F		200°C
C	Stem OD, mm		305 to 315 <sup>NN</sup>			415 to 425		150 to 160
D	Bulb length, mm		6.0 to 8.0			6.0 to 8.0		5.5 to 7.0
E	Bulb OD, mm		7 to 10			15 to 20		10 to 15
	Scale location:		<4.5 and >stem			bulb size >stem size		<5.0 and >stem
F	Bottom of bulb to line at	0°C	32°F	-20°C		-4°F		155°C
G	Distance, mm		45 to 55			35 to 50		50 to 60
	Length of graduated portion,		210 to 240 <sup>O</sup>			305 to 350 <sup>O</sup>		40 to 60 <sup>O</sup>
	mm							
	Ice-point scale:							
	Range							
H	Bottom of bulb to ice-point,							
	mm							
	Contraction chamber:							
I	Distance to bottom, min, mm							
J	Distance to top, max, mm							
K	Stem enlargement:							
L	OD, mm							
M	Length, mm							
	Distance to bottom, mm							30 <sup>F</sup>

<sup>A</sup> An expansion chamber is provided for relief of gas pressure to avoid distortion of the bulb at higher temperatures. It is not for the purpose of joining mercury separations, and under no circumstances should the thermometer be heated above the highest temperature reading.

<sup>C</sup> Under certain test conditions, the bulb of the thermometer may be 28°C (50°F) above the temperature indicated by the thermometer, and at an indicated temperature of 371°C (700°F) the temperature of the bulb is approaching a critical range in the glass. It is therefore not desirable to use this thermometer under such conditions at indicated temperatures above 371°C (700°F) without checking the ice point.

<sup>D</sup> Longest graduation lines at 155°C, 160°C, 162°C, 164°C, 165°C, and 170°C, with arrows at 162°C and 164°C.

<sup>F</sup> Long, narrow shape.

<sup>O</sup> Capillary clearances shall conform to Section 8.

<sup>NN</sup> For Fahrenheit thermometers, dimension G (length of graduated portion) shall be measured as the length of graduated portion corresponding to the nominal Celsius range.

<sup>FF</sup> This thermometer may be furnished with an optional ring top. See 6.2.3. Addition of a ring top will increase the total length by an amount equal to the outside diameter of the ring.

**TABLE 1 Continued**

ASTM No.	14C-86	14F-86 <sup>FF</sup>	15C-86	15F-86 <sup>FF</sup>	16C-86	16F-86 <sup>FF</sup>
IP No.	17C		60C		61C	
Name		Wax Melting Point		Low Softening Point		High Softening Point
Reference Fig. No.		7		4		4
Range	38 to 82°C	100 to 180°F	-2 to +80°C	30 to 180°F	30 to 200°C	85 to 392°F
For test at						
A	Immersion, mm	79		total		total
Graduations:						
Subdivisions	0.1°C	0.2°F	0.2°C	0.5°F	0.5°C	1°F
Long lines at each	0.5°C	1°F	1°C	1°F	1°C	5°F
Numbers at each	1°C	2°F	2°C	5°F	5°C	10°F
Scale error, max	0.1°C	0.2°F	0.2°C	0.4°F	0.3°C	0.5°F
Special inscription		ASTM 14C-86 or 14F-86 79 MM IMM		ASTM 15C-86 or 15F-86		ASTM 16C-86 or 16F-86
Expansion chamber:						
Permit heating to		212°F	130°C	270°F	250°C	482°F
B	Total length, mm	370 to 380		390 to 400		390 to 400
C	Stem OD, mm	6.0 to 8.0		6.0 to 8.0		6.0 to 8.0
D	Bulb length, mm	18 to 28		9 to 14		9 to 14
E	Bulb OD, mm	5.0 to 6.0		4.5 to 5.5		4.5 to 5.5
Scale location:						
F	Bottom of bulb to line at					
Distance, mm	40°C	115 to 125	0°C	32°F	30°C	86°F
G	Length of graduated portion, mm	210 to 240 <sup>o</sup>		75 to 90		75 to 90
Ice-point scale:				245 to 285 <sup>o</sup>		245 to 280 <sup>o</sup>
Range						
H	Bottom of bulb to ice-point, mm					
Contraction chamber:						
I	Distance to bottom, min, mm					
J	Distance to top, max, mm					
Stem enlargement:						
K	OD, mm					
L	Length, mm					
M	Distance to bottom, mm					

<sup>o</sup> Capillary clearances shall conform to Section 8.

<sup>FF</sup> For Fahrenheit thermometers, dimension G (length of graduated portion) shall be measured as the length of graduated portion corresponding to the nominal Celsius range.

TABLE 1 Continued

ASTM No.	17C-86	17F-86 <sup>F</sup>	18C-86	18F-86 <sup>F</sup>	19C-86	19F-86 <sup>F</sup>
IP No.			23C			
Name			Reid Vapor Pressure		Saybolt Viscosity	
Reference Fig. No.			8		8	
Range						
For test at		66 to 80°F	34 to 42°C	94 to 108°F	49 to 57°C	120 to 134°F
A	19 to 27°C	70 and 77°F <sup>G</sup>	37.8°C <sup>G</sup>	100°F <sup>G</sup>	50 and 54.4°C <sup>G</sup>	122 and 130°F <sup>G</sup>
Immersion, mm						
Graduations:						
Subdivisions	0.1°C	0.2°F	0.1°C	0.2°F	0.1°C	0.2°F
Long lines at each	0.5°C	1°F	0.5°C	1°F	0.5°C	1°F
Numbers at each	1°C, except 21	2°F	1°C	2°F	1°C, except 54	2°F
Scale error, max	0.1°C	0.2°F	0.1°C	0.2°F	0.1°C	0.2°F
Special inscription		ASTM			ASTM	
Expansion chamber:		17C-86 or 17F-86	18C-86 or 18F-86		19C-86 or 19F-86	
Permit heating to						
B	100°C	212°F	100°C	212°F	115°C	240°F
Total length, mm						
C			270 to 280		270 to 280	
Stem OD, mm			6.0 to 7.0		6.0 to 7.0	
D			25 to 35		25 to 35	
Bulb length, mm			>stem		<-5.0 and >stem	
E						
Bulb OD, mm						
Scale location:						
F	19°C	66°F	34°C	94°F	49°C	120°F
Bottom of bulb to line at						
G			130 to 150		135 to 150	
Distance, mm			60 to 90 <sup>O</sup>		67 to 101 <sup>O</sup>	
Length of graduated portion, mm						
Ice-point scale:						
Range						
H						
Bottom of bulb to ice-point, mm						
Contraction chamber:						
I						
Distance to bottom, min, mm						
J						
Distance to top, max, mm						
Stem enlargement:						
K						
OD, mm						
L						
Length, mm						
M						
Distance to bottom, mm						

<sup>G</sup> The test temperatures shall be indicated by an arrow whether the graduation corresponding to that point is numbered or not.

<sup>H</sup> Long, narrow shape; mercury shall be in the chamber at 0°C (32°F).

<sup>O</sup> Capillary clearances shall conform to Section 8.

<sup>F</sup> For Fahrenheit thermometers, dimension G (length of graduated portion) shall be measured as the length of graduated portion corresponding to the nominal Celsius range.

TABLE 1 Continued

ASTM No.	20C-86	20F-86 <sup>FF</sup>	21C-86	21F-86 <sup>FF</sup>	22C-86	22F-86 <sup>FF</sup>
IP No.						
Name						
Reference Fig. No.						
Range						
For test at						
A	Immersion, mm	134 to 148°F 140°F <sup>G</sup>	79 to 87°C 82.2°C <sup>G</sup>	174 to 188°F 180°F <sup>G</sup>	95 to 103°C 98.9 and 100°C <sup>G</sup>	204 to 218°F 210°F <sup>G</sup>
	Graduations:					
	Subdivisions	0.1°C	0.1°C	0.2°F	0.1°C	0.2°F
	Long lines at each	0.5°C	0.5°C	1°F	0.5°C	1°F
	Numbers at each	1°C	1°C, except 82	2°F	1°C	2°F
	Scale error, max	0.1°C	0.1°C	0.2°F	0.1°C	0.2°F
	Special inscription	ASTM	ASTM	ASTM	ASTM	ASTM
	Expansion chamber:					
	Permit heating to	20C-86 or 20F-86	21C-86 or 21F-86		22C-86 or 22F-86	
B	Total length, mm	115°C	140°C	285°F	155°C	310°F
C	Stem OD, mm	270 to 280	270 to 280	6.0 to 7.0	270 to 280	6.0 to 8.0
D	Bulb length, mm	6.0 to 7.0	6.0 to 7.0	25 to 35	25 to 35	25 to 35
E	Bulb OD, mm	25 to 35	25 to 35	<5.0 and ≥stem	<5.0 and ≥stem	<5.0 and ≥stem
	Scale location:					
F	Bottom of bulb to line at	57°C	79°C	174°F	95°C	204°F
G	Distance, mm	135 to 150	135 to 150	67 to 101 <sup>O</sup>	135 to 150	70 to 100 <sup>O</sup>
	Length of graduated portion, mm	67 to 101 <sup>O</sup>	67 to 101 <sup>O</sup>			
	Ice-point scale:					
H	Range					
	Bottom of bulb to ice-point, mm					
I	Contraction chamber:					
J	Distance to bottom, min, mm					
	Distance to top, max, mm					
K	Stem enlargement:					
L	OD, mm	8.0 to 10.0	8.0 to 10.0	8.0 to 10.0	8.0 to 10.0	8.0 to 10.0
M	Length, mm	4.0 to 7.0	4.0 to 7.0	4.0 to 7.0	4.0 to 7.0	4.0 to 7.0
	Distance to bottom, mm	112 to 116	112 to 116	112 to 116	112 to 116	112 to 116

<sup>G</sup> The test temperatures shall be indicated by an arrow whether the graduation corresponding to that point is numbered or not.

<sup>H</sup> Long, narrow shape; mercury shall be in the chamber at 0°C (32°F).

<sup>O</sup> Capillary clearances shall conform to Section 8.

<sup>FF</sup> For Fahrenheit thermometers, dimension G (length of graduated portion) shall be measured as the length of graduated portion corresponding to the nominal Celsius range.

TABLE 1 Continued

IP No.	ASTM No.	23C-86	24C-86	25C-86
Name				
Reference Fig. No.				
Range				
For test at				
A Immersion, mm				
Graduations:				
Subdivisions				
Long lines at each				
Numbers at each				
Scale error, max				
Special inscription				
Expansion chamber:				
Permit heating to				
B Total length, mm				
C Stem OD, mm				
D Bulb length, mm				
E Bulb OD, mm				
Scale location:				
Bottom of bulb to line at				
F Distance, mm				
G Length of graduated portion, mm				
Ice-point scale:				
Range				
Bottom of bulb to ice-point, mm				
H Contraction chamber:				
I Distance to bottom, min, mm				
J Distance to top, max, mm				
K Stem enlargement:				
OD, mm				
L Length, mm				
M Distance to bottom, mm				
Engler Viscosity <sup>1</sup>				
7 <sup>K</sup>				
Engler Viscosity <sup>1</sup>				
7 <sup>K</sup>				
Engler Viscosity <sup>1</sup>				
7 <sup>K</sup>				

<sup>1</sup>The thermometer shall be made to be mounted in a brass ferrule consisting of a tubular bushing 8.0 mm in outside diameter with a flanged head approximately 12 mm in diameter so that the upper extremity of the 8.0 mm diameter is located 90 mm from the bottom of the bulb.

<sup>J</sup>To be marked on the glass stem at least 90 mm from the bottom of the bulb.

<sup>K</sup>Glass button finish, see 6.2.1.

<sup>L</sup>Long, narrow shape; mercury shall be near bottom of the chamber at 0°C.

<sup>O</sup>Capillary clearances shall conform to Section 8.