

INTERNATIONAL
STANDARD

ISO
12261

First edition
1996-11-01

**Aerospace — Screws, pan head, internal
offset cruciform ribbed or unribbed drive,
pitch diameter shank, long length MJ
threads, metallic material, coated or
uncoated, strength classes less than or
equal to 1 100 MPa — Dimensions**

ISO 12261:1996

<https://standards.iteh.ai/catalog/standards/sist/9368bc23-f73d-43d2-b4db-70c93c459611/iso-12261-1996>

Aéronautique et espace — Vis à tête cylindrique, à empreinte cruciforme déportée, avec ou sans saillies antidérapantes, à tige de diamètre égal au diamètre sur flancs et filetage MJ long, en matériau métallique, revêtues ou non revêtues, des classes de résistance inférieures ou égales à 1 100 MPa — Dimensions

INTERNATIONAL

ISO



Reference number
ISO 12261:1996(E)

Foreword

ISO (the International Organization for Standardization) is a worldwide federation of national standards bodies (ISO member bodies). The work of preparing International Standards is normally carried out through ISO technical committees. Each member body interested in a subject for which a technical committee has been established has the right to be represented on that committee. International organizations, governmental and non-governmental, in liaison with ISO, also take part in the work. ISO collaborates closely with the International Electrotechnical Commission (IEC) on all matters of electrotechnical standardization.

Draft International Standards adopted by the technical committees are circulated to the member bodies for voting. Publication as an International Standard requires approval by at least 75 % of the member bodies casting a vote.

iTeh STANDARD PREVIEW

International Standard ISO 12261 was prepared by Technical Committee ISO/TC 20, *Aircraft and space vehicles*, Subcommittee SC 4, *Aerospace fastener systems*.

ISO 12261:1996

<https://standards.iteh.ai/catalog/standards/sist/9368bc23-f73d-43d2-b4db-70c93c459611/iso-12261-1996>

© ISO 1996

All rights reserved. Unless otherwise specified, no part of this publication may be reproduced or utilized in any form or by any means, electronic or mechanical, including photocopying and microfilm, without permission in writing from the publisher.

International Organization for Standardization
Case Postale 56 • CH-1211 Genève 20 • Switzerland

Printed in Switzerland

Aerospace — Screws, pan head, internal offset cruciform ribbed or unribbed drive, pitch diameter shank, long length MJ threads, metallic material, coated or uncoated, strength classes less than or equal to 1 100 MPa — Dimensions

1 Scope

This International Standard specifies the dimensions of pan head screws with internal offset cruciform ribbed or unribbed drive, pitch diameter shank and long length MJ threads, in metallic material, coated or uncoated, with strength classes less than or equal to 1 100 MPa.

This International Standard is applicable to the compilation of aerospace product standards.

2 Normative references

The following standards contain provisions which, through reference in this text, constitute provisions of this International Standard. At the time of publication, the editions indicated were valid. All standards are subject to revision, and parties to agreements based on this International Standard are encouraged to investigate the possibility of applying the most recent editions of the standards indicated below. Members of IEC and ISO maintain registers of currently valid International Standards.

ISO 3353:1992, *Aerospace — Rolled threads for bolts — Lead and runout requirements.*

ISO 5855-2:1988, *Aerospace — MJ threads — Part 2: Limit dimensions for bolts and nuts.*

ISO 7913:1994, *Aerospace — Bolts and screws, metric — Tolerances of form and position.*

ISO 14275:—¹⁾, *Aerospace — Drives, internal, offset cruciform, ribbed — Metric series.*

ISO 14276:—¹⁾, *Aerospace — Drives, internal, offset cruciform — Metric series.*

3 Configuration and dimensions

See figure 1 and table 1. Dimensions and tolerances are expressed in millimetres. They are applicable after any surface coating, but before the application of any lubricant.

Tolerances of form and position are specified in ISO 7913.

1) To be published.

Break sharp edges 0,1 to 0,4

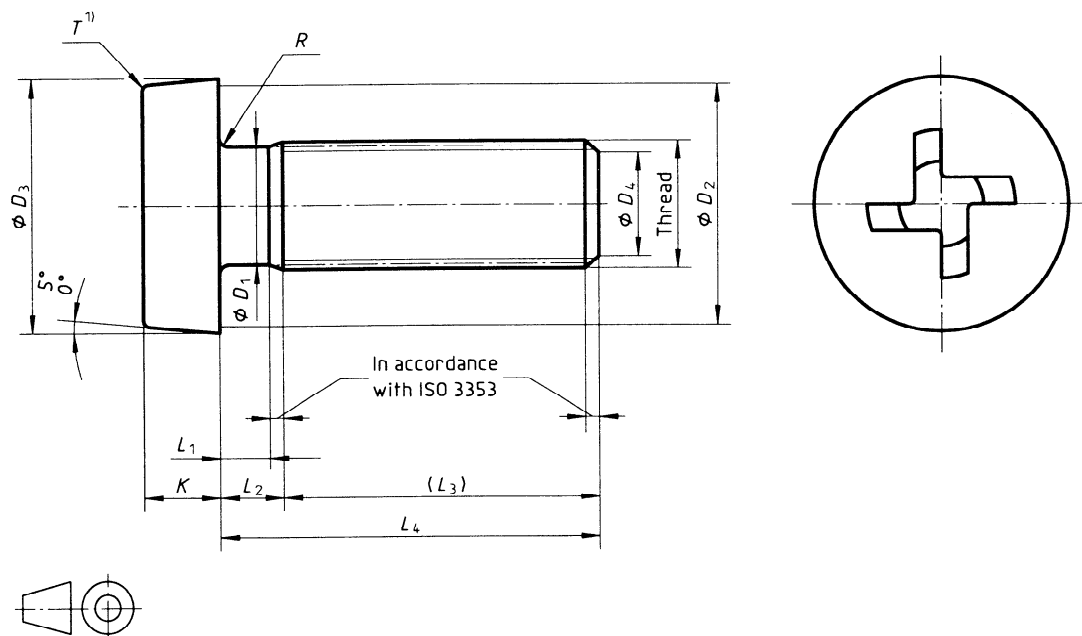

1) Shape optional

Figure 1

iTeh STANDARD PREVIEW
(standards.iteh.ai)

Table 1

<https://standards.iteh.ai/catalog/standards/sist/9368bc23-f73d-43d2-b4db-70c93c45961/iso-12261-1996>

Diameter code	Thread ¹⁾	D_1	D_2	D_3	D_4		K	L_1 2) 3) 4)		L_2 2) 3) 4)		L_3	L_4 4)		R		T		Drive code ⁵⁾
		$\pm 0,13$	min.	$\begin{matrix} 0 \\ -0,3 \end{matrix}$	nom.	tol.		nom.	tol.	min.	max.		nom.	tol.	nom.	tol.	max.	min.	
040	MJ4×0,7 – 4h6h	3,54	6,7	8	3	$\begin{matrix} 0 \\ -0,5 \end{matrix}$	2,4	0,4	2	14	16 to 56	0,4	1,6	0,4	R4				
050	MJ5×0,8 – 4h6h	4,48	8,7	10	3,4	$\pm 0,5$	3	0,5	4	16	20 to 70	0,5	2	0,5	R5				
060	MJ6×1 – 4h6h	5,35	10,7	12	4,2		3,6	0,7		18	22 to 84	0,7	2,4	0,6	R6				
070	MJ7×1 – 4h6h	6,35	12,7	14	5,2	$\begin{matrix} 0 \\ -0,3 \end{matrix}$	4,2	6	20	24 to 98	0,7	2,8	0,7	R6					
080	MJ8×1 – 4h6h	7,35	14,7	16	6,2		4,8		22	26 to 112	0,8	3,2	0,8	R8					
100	MJ10×1,25 – 4h6h	9,19	18,7	20	7,9	$\begin{matrix} 0 \\ -0,3 \end{matrix}$	6	0,8	6	26	32 to 140	0,8	4	1	R10				
120	MJ12×1,25 – 4h6h	11,19	22,7	24	9,8		7,2	0,9		30	36 to 168	0,9	4,8	1,2	R12				

- 1) In accordance with ISO 5855-2
- 2) First length corresponding to first L_4 length
- 3) Conditions L_1 min. and L_2 max. cannot be obtained simultaneously.
- 4) Increments:
2 for $L_4 \leq 100$
4 for $L_4 > 100$
- 5) In accordance with ISO 14275 or ISO 14276

iTeh STANDARD PREVIEW
This page intentionally left blank
(standards.iteh.ai)

ISO 12261:1996

<https://standards.iteh.ai/catalog/standards/sist/9368bc23-f73d-43d2-b4db-70c93c459611/iso-12261-1996>

iTeh STANDARD PREVIEW
This page intentionally left blank
(standards.iteh.ai)

ISO 12261:1996

<https://standards.iteh.ai/catalog/standards/sist/9368bc23-f73d-43d2-b4db-70c93c459611/iso-12261-1996>

iTeh STANDARD PREVIEW
This page intentionally left blank
(standards.iteh.ai)

ISO 12261:1996

<https://standards.iteh.ai/catalog/standards/sist/9368bc23-f73d-43d2-b4db-70c93c459611/iso-12261-1996>

iTeh STANDARD PREVIEW
(standards.iteh.ai)

ISO 12261:1996

<https://standards.iteh.ai/catalog/standards/sist/9368bc23-f73d-43d2-b4db-70c93c459611/iso-12261-1996>

ICS 49.040.20

Descriptors: aircraft industry, fasteners, threaded fasteners, MJ threads, pan head screws, cross recessed screws, offset-cross recessed screws, dimensions, dimensional tolerances.

Price based on 2 pages
