



Standard Test Method for Measuring Liquid and Solid Material Fire Limits in Gaseous Oxidants¹

This standard is issued under the fixed designation G 125; the number immediately following the designation indicates the year of original adoption or, in the case of revision, the year of last revision. A number in parentheses indicates the year of last reapproval. A superscript epsilon (ϵ) indicates an editorial change since the last revision or reapproval.

^{ε1} NOTE—Editorial corrections were made in April 1996.

1. Scope

1.1 This test method covers a procedure for measuring the threshold-limit conditions to allow equilibrium of combustion of materials in various oxidant gases under specific test conditions of pressure, temperature, flow condition, fire-propagation directions, and various other geometrical features of common systems.

1.2 This test method is patterned after Test Method D 2863 and incorporates its procedure for measuring the limit as a function of oxidant concentration for the most commonly used test conditions. Sections 8, 9, 10, 11, 13, and 14 for the basic oxidant limit (oxygen index) procedure are quoted directly from Test Method D 2863. Oxygen index data reported in accordance with Test Method D 2863 are acceptable substitutes for data collected with this standard under similar conditions. It is anticipated that later revisions of Test Method D 2863 will yield similarly equivalent results, and as new revisions of Test Method D 2863 are issued, any changes will be Test Method reviewed for incorporation into this test method.

1.3 This test method has been found applicable to testing and ranking various forms of materials. It has also found limited usefulness for surmising the prospect that materials will prove “oxygen compatible” in actual systems. However, its results do not necessarily apply to any condition that does not faithfully reproduce the conditions during test. The fire limit is a measurement of a behavioral property and not a physical property. Uses of these data are addressed in Guides G 63 and G 94.

NOTE 1—Although this test method has been found applicable for testing a range of materials in a range of oxidants with a range of diluents, the accuracy has not been determined for many of these combinations and conditions of specimen geometry, outside those of the basic procedure as applied to plastics.

1.4 One very specific set of test conditions for measuring

the fire limits of metals in oxygen has been codified in Test Method G 124. Test Method G 124 measures the minimum pressure limit in oxygen for its own set of test conditions. Its details are not reproduced in this standard. A substantial database is available for this procedure, although it is much smaller than the database for Test Method D 2863.

NOTE 2—**Warning:** During the course of combustion, gases, vapors, aerosols, fumes or any combination of these are evolved which may be hazardous.

NOTE 3—**Precaution:** Adequate precautions should be taken to protect the operator.

1.5 The values stated in SI units are to be regarded as the standard.

1.6 *This basic standard should be used to measure and describe the properties of materials, products, or assemblies in response to heat and flame under controlled laboratory conditions and should not be used to directly describe or appraise the fire hazard or fire risk of materials, products or assemblies under actual fire conditions. However, results of this test may be used as elements of a fire risk assessment which takes into account all of the factors which are pertinent to an assessment of the fire hazard of a particular end use. The standard has more applicability in this regard at predicting the fire behavior of materials and components that are close in size to the test condition, than for systems that are much different (for example: comparing a test rod to a valve seat rather than comparing a test rod to a house or a particle)*

1.7 *This standard does not purport to address all of the safety concerns, if any, associated with its use. It is the responsibility of the user of this standard to establish appropriate safety and health practices and determine the applicability of regulatory limitations prior to use.*

2. Referenced Documents

2.1 ASTM Standards:

D 618 Practice for Conditioning Plastics and Electrical Insulating Materials for Testing²

¹ This test method is under the jurisdiction of ASTM Committee G-4 on Compatibility and Sensitivity of Materials in Oxygen-Enriched Atmospheres and is the direct responsibility of Subcommittee G 4.01 on Test Methods. Portions have been adapted from Test Method D 2863 that is under the jurisdiction of ASTM Committee D-20 on Plastics.

Current edition approved Jan. 15, 1995. Published March 1995. Originally published as G 125 – 94. Last previous edition G 125 – 94.

² Annual Book of ASTM Standards, Vol 08.01.

- D 1071 Test Method for Volumetric Measurement of Gaseous Fuel Samples³
- D 2444 Test Method for Impact Resistance of Thermoplastic Pipe and Fittings by Means of a Tup (Falling Weight)⁴
- D 2863 Test Method for Measuring the Minimum Oxygen Concentration to Support Candle-Like Combustion of Plastics (Oxygen Index)⁵
- G 63 Guide for Evaluating Nonmetallic Materials for Oxygen Service⁶
- G 94 Guide for Evaluating Metals for Oxygen Service⁶
- G 124 Test Method for Determining the Combustion Behavior of Metallic Materials in Oxygen-Enriched Atmospheres⁶
- G 128 Guide for the Control of Hazards and Risks in Oxygen Systems⁶

3. Terminology

3.1 Definitions:

3.1.1 *oxygen compatibility, n*—the ability of a substance to coexist with both oxygen and a potential source(s) of ignition within the acceptable risk parameter of the user (at an expected pressure and temperature). (See Guide G 128.)

3.1.2 *oxygen index, n*—the minimum concentration of oxygen, expressed as a volume percent, in a mixture of oxygen and nitrogen that will just support flaming combustion of a material initially at room temperature under the conditions of Test Method D 2863. (See Test Method D 2863.)

3.2 Definitions of Terms Specific to This Standard:

3.2.1 *fire limit, n*—the threshold limit conditions that will just support sustained combustion of a material under a combination of specified conditions and at least one variable parameter (typically oxidant concentration, diluent nature, pressure, temperature, geometry, flow or flame parameters, etc.).

3.2.2 *oxidant compatibility, n*—the ability of a substance to coexist with both an oxidant and a potential source(s) of ignition within the acceptable risk parameter of the user (at an expected pressure and temperature).

3.2.3 *oxidant index, n*—the minimum concentration of an oxidant such as oxygen, nitrous oxide, fluorine, etc., expressed as a volume percent, in a mixture of the oxidant with a diluent such as nitrogen, helium, carbon dioxide, etc., that will just support sustained combustion of a material initially at given conditions of temperature, pressure, flow conditions, propagation direction, etc. (See also, *oxygen index*.)

3.2.3.1 *Discussion*—The oxidant index may be more specifically identified by naming the oxidant: oxygen limit (or index), nitrous oxide limit (or index), fluorine limit (or index), etc. Unless specified otherwise, the typical oxidant is taken to be oxygen, the typical diluent is taken to be nitrogen, and the typical temperature is taken as room temperature.

3.2.4 *pressure limit*—the minimum pressure of an oxidant (or mixture) that will just support sustained combustion of a material initially at given conditions of oxidant concentration,

temperature, flow condition, propagation direction, etc.

3.2.4.1 *Discussion*—The pressure limit may be more specifically identified by naming the oxidant: oxygen pressure limit, nitrous oxide pressure limit, fluorine pressure limit, etc.

3.2.5 *temperature limit*—the minimum temperature of an oxidant (or mixture) that will just support sustained combustion of a material initially at given conditions of oxidant concentration, temperature, flow condition, propagation direction, etc.

3.2.5.1 *Discussion*—The temperature limit may be more specifically identified by naming the oxidant: oxygen temperature limit, nitrous oxide temperature limit, fluorine temperature limit, etc.

4. Summary of Test Method

4.1 The threshold limit condition (minimum oxidant concentration, minimum pressure, minimum temperature, etc.) that will just support sustained combustion under equilibrium conditions is measured in a test apparatus. The equilibrium is established by the relation between the heat generated from the combustion of the specimen (that may be augmented by the heat of decomposition of some oxidants) and the heat lost to the surroundings as measured by one or the other of two arbitrary criteria, namely, a time of burning or a length of specimen burned. This point is approached from both sides of the critical threshold condition in order to establish the fire limit.

5. Significance and Use

5.1 This test method provides for measuring of the minimum conditions of a range of parameters (concentration of oxidant in a flowing mixture of oxidant and diluent, pressure, temperature) that will just support sustained propagation of combustion. For materials that exhibit flaming combustion, this is a flammability limit similar to the lower flammability⁷ limit, upper flammability limit, and minimum oxidant for combustion of gases (1). However, unlike flammability limits for gases, in two-phase systems, the concept of upper and lower flame limits is not meaningful. However, limits can typically be determined for variations in other parameters such as the minimum oxidant for combustion (the oxidant index), the pressure limit, the temperature limit, and others. Measurement and use of these data are analogous to the measurement and use of the corresponding data for gaseous systems. That is, the limits apply to systems likely to experience complete propagations (equilibrium combustion). Successful ignition and combustion below the measured limits at other conditions or of a transient nature are not precluded below the threshold. Flammability limits measured at one set of conditions are not necessarily the lowest thresholds at which combustion can occur. Therefore direct correlation of these data with the burning characteristics under actual use conditions is not implied.

6. Abstract

6.1 A well-established procedure for measuring an oxidant

³ Annual Book of ASTM Standards, Vol 05.05.

⁴ Annual Book of ASTM Standards, Vol 08.04.

⁵ Annual Book of ASTM Standards, Vol 08.02.

⁶ Annual Book of ASTM Standards, Vol 14.02.

⁷ The boldface numbers in parenthesis refer to the references listed at the end of this guide.

limit, the oxygen index, of plastics (See Test Method D 2863) is reviewed, then variations commonly used to collect data for oxidant compatibility purposes are described. In the test, a series of specimens is placed in a preadjusted oxidant mixture and deliberately ignited. Specimens that do not “burn” are retested in higher concentrations. Specimens that do burn are retested in lower concentrations. When the operator is confident that the threshold has been determined by a suitable number and spread of negative tests below the threshold, the lowest positive is reported as the oxidant.

6.2 Similar test methods apply when the oxidant concentration is held constant and the temperature, pressure or other key factor is varied. In some cases, apparatus modification or replacement is necessary, such as a pressurized vessel is required to complete some tests (see Test Method G 124). Relatively little work (1-18) has been done using oxidants other than oxygen, diluents other than nitrogen, pressure, temperature, or other properties as the variable parameter.

7. Variations

7.1 A number of variations of the procedure have been used. The principle variables have been oxidant, diluent, pressure, temperature, flow condition and flow direction. Relatively little work has been done for most of these variables (1-18). There is some qualitative and even quantitative understanding of the manner in which these variables affect the fire limits of materials, but the understanding is largely incomplete. Finally, the database for most combinations of variables is small (only Test Method D 2863 and Test Method G 124 have significant databases) and so the ability to draw strong conclusions is limited. Nonetheless, where data is obtained for two or more materials, these data are useful to the evaluation of those materials. Care is necessary in comparing materials that have not been tested in similar procedures.

7.2 *Oxidants*—Changing the oxidant may cause the greatest changes in results for other constant conditions (1, 2, 3). Oxidants behave dramatically different, because their basic chemistry with differing materials is different. For example, even though nitrous oxide is a combination of nitrogen and oxygen, it behaves much differently than a similar oxygen/nitrogen mixture. During combustion, nitrous oxide decomposes to release heat that renders it more able to support combustion than a simple mixture. Fluorine is very reactive and produces more gaseous product species which changes its behavior in higher purity oxidant. There are data available in varying amounts for the oxidants: oxygen, nitrous oxide, fluorine, nitrogen trifluoride, and nitrogen (nitrogen is an oxidant in some cases, a diluent in others).

7.3 *Diluents*—Varying diluents can have a significant effect although much less impressive than oxidant, pressure or even flow direction (1-8). Diluent’s thermal conductivity and heat capacity appear to be the most significant properties. Reactivity is a second issue. For example, nitrogen does not participate in most polymer combustions but can react with some metals and exhibit widely different diluent natures. Among the diluents used to date are nitrogen, helium, argon, carbon dioxide, neon, and xenon.

7.4 *Pressures*—Pressure has a dramatic effect on the fire limit (1, 4, 5, 8, 9, 10, 11). The role of pressure is complex, yet

it is one of the most important variables because oxygen systems employ a range of pressures to 82 MPa (12000 psig).

7.5 *Temperatures*—The role of temperature appears to be among the more straightforward higher temperatures appear to imply lower fire limits. The effect can be gradual or abrupt. For example PTFE will not burn in the oxygen index test at room temperature, but burns nicely at just a few degrees above room temperature (9, 12).

7.6 Flow and Propagation Schemes:

7.6.1 Variations in the flow scheme and the direction of propagation have dramatic effect on the fire limit. The earliest work on oxygen index (8) demonstrated that for polymers, a much lower index resulted if the flow carried the hot combustion products over the unburned portions of a specimen. Later work confirms the observation (9, 13, 14) (Therefore in most polymer testing, lower limits were measured if the specimens were bottom ignited with upward flow or top ignited with downward flow than with the standard top ignition with upward flow. The effect is similar but less dramatic with metals combustion. Indeed, the standard top-ignition upward-flow conditions of Test Method D 2863 and bottom-ignition conditions of Test Method G 124 were chosen to facilitate the measurement and its precision rather than to obtain the lowest-possible limit measurement. Similarly, in stagnant systems, a concentration of inert combustion products, diluents, and even impurities in the oxidant gases can yield higher limits than otherwise. Limited work has been done with most of the combinations of vertical (upward or downward) flow and vertical directions of propagation.

7.6.2 Variations in the flow scheme have been used (3, 6, 7) in which a fire was established in the bore (intraluminal flame) of a flowing horizontal tube. These demonstrated that the effect of diluents can be inverted at high flow rates and that there can be an optimum velocity that yields a minimum fire limit.

7.7 Geometries:

7.7.1 The influence of geometry is not well understood, but work shows that specimen size (8) is not a particularly significant variant in polymer tests performed as in Sections 8, 9, 10, 11, 13, and 14, but that the change from rod to tubing can have a dramatic effect on the fire limit of stainless steel but may have a much smaller effect on carbon steel (5).

7.7.2 Powders and liquids have been tested (15, 16) with slight modification of Test Method D 2863. Typically, powders have had lower fire limits than their bulk counterparts. Few materials can be tested as both liquid and solid. However, data suggest that if materials could be tested as solids or gases, the gases would exhibit a lower fire limit (1).

8. Apparatus

8.1 *Test Column*, consisting of a heat-resistant glass tube of 75 mm minimum inside diameter and 450 mm minimum height. The bottom of the column or the base to which the tube is attached shall contain noncombustible material to mix and distribute evenly the gas mixture entering at this base. Glass beads 3 to 5 mm in diameter in a bed 80 to 100 mm deep have been found suitable (an example is shown in Fig. 1).

NOTE 4—A column with a 95-mm inside diameter and 210 mm high with a restricted upper opening (diameter = 50 mm) has been found to give equivalent results.

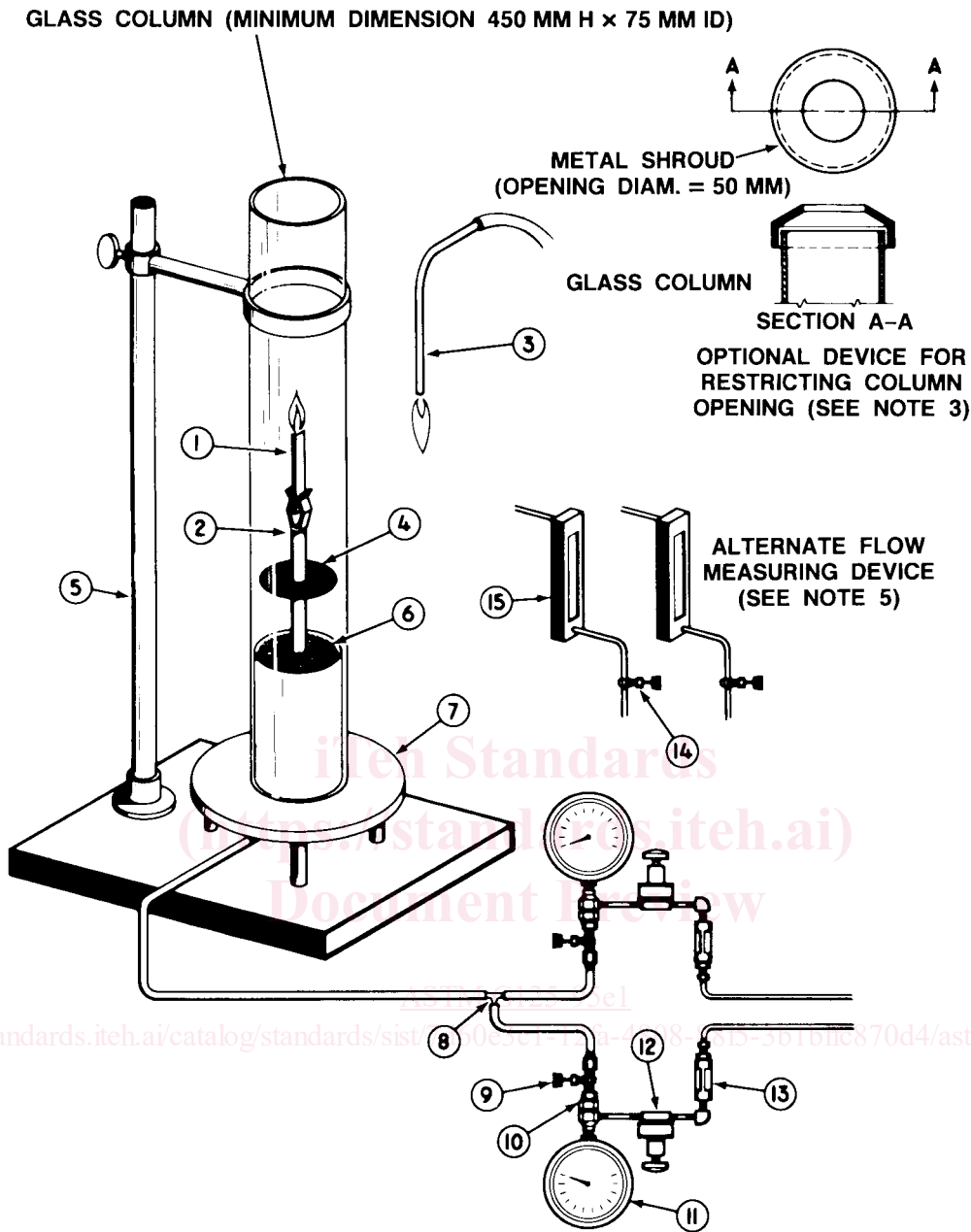

FIG. 1 Typical Equipment Layout

NOTE 5— It is helpful to place a wire screen above the noncombustible material to catch falling fragments and aid in keeping the base of the column clean.

8.2 *Specimen Holder*—Any small holding device that will support the specimen at its base and hold it vertically in the center of the column is acceptable. For physically self-supporting specimens, a typical arrangement (See Fig. 1) consists of a laboratory thermometer clamp inserted into the end of a glass tube held in place by glass beads or otherwise firmly supported. For other forms, such as film and thin sheet,

the frame shown in Fig. 2 shall be used and held in place by the above tube. The test specimen must be held securely along both upright edges by the frame, using clips or other means.

8.3 *Gas Supply*—Commercial grade (or better) oxygen and nitrogen shall be used. If an air supply is used with oxygen or nitrogen, it must be clean and dry.

8.4 *Flow Measurements and Control Devices*—Suitable flow measurement and control devices shall be available in each line that will allow monitoring the volumetric flow of