



Designation: C 648 – 98

## Standard Test Method for Breaking Strength of Ceramic Tile<sup>1</sup>

This standard is issued under the fixed designation C 648; the number immediately following the designation indicates the year of original adoption or, in the case of revision, the year of last revision. A number in parentheses indicates the year of last reapproval. A superscript epsilon ( $\epsilon$ ) indicates an editorial change since the last revision or reapproval.

### 1. Scope

1.1 This test method covers the determination of the breaking strength of glazed ceramic wall tile, ceramic mosaic tile, quarry tile, and paver tile, having a facial area of at least 1 in.<sup>2</sup> (6.4 cm<sup>2</sup>).

1.2 The values stated in inch-pound units are to be regarded as the standard. The metric equivalents of inch-pound units may be approximate.

1.3 *This standard does not purport to address all of the safety concerns, if any, associated with its use. It is the responsibility of the user of this standard to establish appropriate safety and health practices and determine the applicability of regulatory limitations prior to use.*

### 2. Referenced Documents

#### 2.1 ASTM Standards:

C 242 Terminology of Ceramic Whitewares and Related Products<sup>2</sup>

E 178 Practice for Dealing with Outlying Observations<sup>3</sup>

### 3. Terminology

#### 3.1 Definitions:

3.1.1 For definitions of the types of tile listed in Section 1, refer to Terminology C 242.

### 4. Summary of Test Method

4.1 The test method consists of supporting the tile on the ends of three cylindrical rods, or on three ball bearings for tiles having an actual facial area of 9 in.<sup>2</sup> (58 cm<sup>2</sup>) (or less), arranged in an equilateral triangle, and applying force at a definite rate to the center of the tile, which coincides with the center of the triangular support, until the specimen breaks.

NOTE 1—The size (facial dimensions) of otherwise equal tile affects the value of breaking strength obtained by this test method. For instance, a 6 by 6-in. (152 by 152-mm) tile equal in mature body properties and thickness to a 4¼ by 4¼-in. (108 by 108-mm) tile will have a breaking strength higher than the 4¼ by 4¼-in. tile.

<sup>1</sup> This test method is under the jurisdiction of ASTM Committee C-21 on Ceramic Whitewares and Related Products and is the direct responsibility of Subcommittee C21.06 on Ceramic Tile.

Current edition approved July 10, 1998. Published January 1999. Originally published as C 648 – 70. Last previous edition C 648 – 84 (1994).

<sup>2</sup> *Annual Book of ASTM Standards*, Vol 15.02.

<sup>3</sup> *Annual Book of ASTM Standards*, Vol 14.02.

### 5. Significance and Use

5.1 The test method provides means for establishing whether or not a lot of ceramic tile meets the strength requirements which may appear in tile specifications. Tile strength is the force in pounds-force (or newtons), as read from the pressure gage, necessary to cause the tile to break.

### 6. Apparatus

6.1 *Specimen-Support*, consisting of a 5½ by 5½ by 1-in. (139.7 by 139.7 by 25.4-mm) steel block. Three ¼-in. (6.4-mm) diameter and ⅜-in. (9.5-mm) deep tapped holes are arranged in an equilateral triangle having 3-in. (76.2-mm) sides and whose circumscribed circle has a radius of 1.732 in. (44.0 mm). The equilateral triangle is located on the steel block so that its center coincides with that of the steel block and one side of the triangle runs parallel to one side of the steel block. Three ⅜-in. diameter steel rods, 1⅜ in. with (34.9 mm) long, one end threaded for a distance of ⅜ in. with the same ¼-in. thread as the tapped holes, and the other end ground flat, fit into the three holes. In a similar manner, a second set of three ⅜-in. diameter steel rods, but ¾ in. (19.0 mm) long only, are threaded on one end for a distance of ⅜-in., are ground flat on the other end and fit three other ¼-in. tapped holes. The three ¼-in. holes, tapped for a distance of ⅜ in. to receive this second set of steel rods are located at the apexes of an equilateral triangle having 1½-in. (38.1-mm) long sides and whose circumscribed circle has a radius of 0.866 in. (22.0 mm). This second equilateral triangle is located within the first one in such a manner that its circumscribed circle is identical with the inscribed circle of the first triangle, and its sides are parallel to those of the larger triangle. The ball bearing support consists of three ⅛-in. (3.2-mm) ball bearings arranged in an equilateral triangle, with sides of 14 mm concentric and parallel with the other triangles. The bearings are embedded in the block to the extent of half their volume. The steel block has four more ¼-in. tapped holes to receive socket head cap screws for holding four registry stops. One of these holes is located in the center of one side, ¼ in. in from the edge. Another of these is located in the center of an adjacent side ¼ in. from the edge. The other two are located on an adjacent side, ¼ in. in from the edge, spaced 2 in. (50.8 mm) apart, with one located 1¾ in. (44.4 mm) from one of the corners of the first side. The two single hole registry

stops are used with the ball bearing support. The double hole registry stop and the adjacent edge single stop are to be used with the sets of rod supports. Three of the registry stops designed for use with the cylindrical rod supports consist of 1/8-in. (3.2-mm) thick steel strips, 3/4 in. wide, 2 in. long, with a 1/4-in. wide slot extending for the full 2-in. length of the strip. The slot is open on one end and the other end of each steel strip has a 3/4 in. wide and 1 1/2 in. high projection, 1/8 in. thick, which will contact the edges of the tile when in proper position for use. The other two registry stops, designed for use with the ball bearing support, have exactly the same dimensions except for their projection height which is 5/8 in. The projection is obtained by making the steel strips actually 3 1/2 in. (88.9 mm) long and bending them at right angles to obtain the 1 1/2-in. or 5/8-in. (38.1-mm or 15.9-mm) high projection. Each of the three registry stops can be fastened with washer and socket head cap screw through its slot in any one of numerous positions. Being adjustable, they serve as registry stops for the different sizes of

tile which may be broken over these supports. For tile of dimensions 4 1/4 in. (107.9 mm) or smaller, the projections will be located on that end of the strip nearest to the support block; for tile having dimensions larger than 4 1/4 in., the strips are reversed so that the projections are located on the end of the steel strips away from the support block (see Fig. 1). For certain mosaic tiles with dimensions of less than 1 in. (25.4 mm) length, it is necessary to reverse the position of the registry stops so that the tile is supported with the slot ends in order to avoid interference with the force applicator.

6.2 Force Applicator— Force is applied in the exact center of the triangular support by means of a 1/2-in. (12.7-mm) diameter stainless steel ball bearing, countersunk to a depth of 17/64 in. (6.7 mm) into one end of a 1-in. (25.4-mm) diameter and 2-in. long steel rod. A 3/32-in. (2.4-mm) thick retaining collar prevents the ball from falling out of its recess and is fastened to the steel rod by four 3/32-in. 3-48 NC screws, 3/8 in. (9.5 mm) long, with countersunk heads. The opposite end of

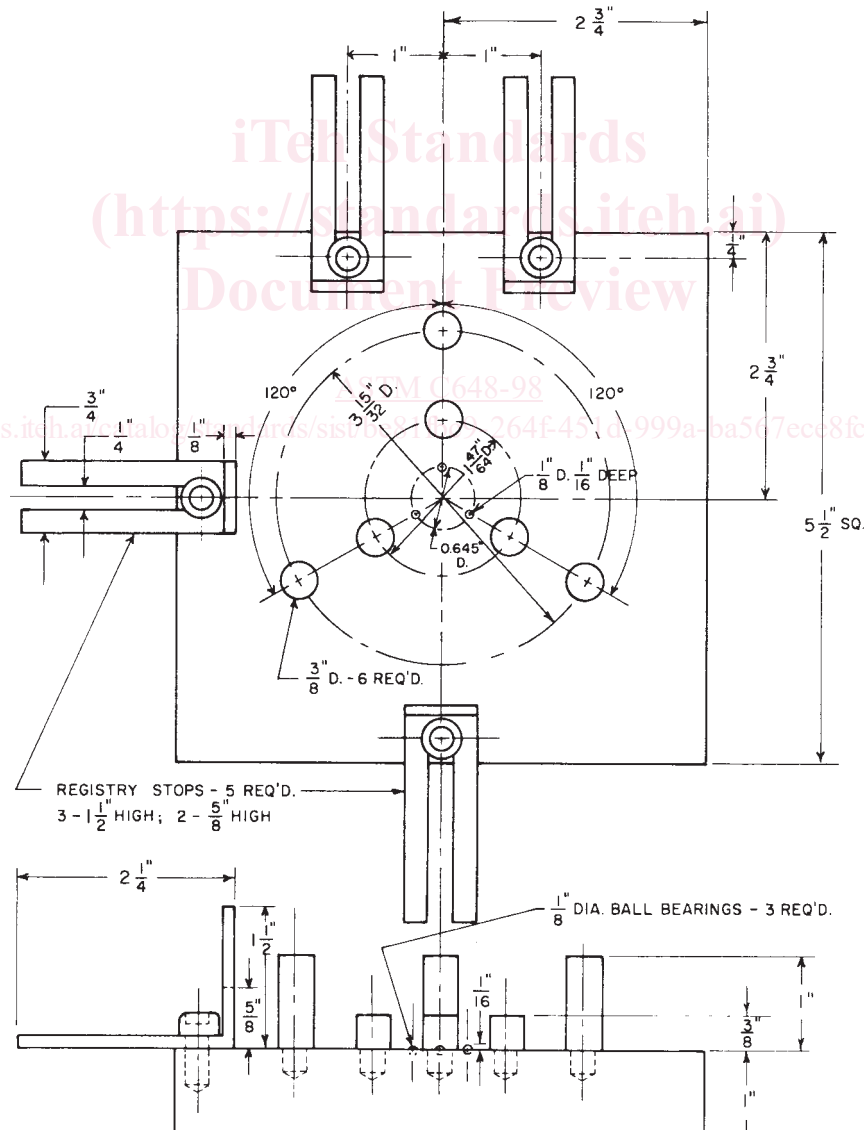

FIG. 1 Support Block Assembly (See Table 1)