



Designation: C 24 – 89 (Reapproved 1999)^{€1}

Standard Test Method for Pyrometric Cone Equivalent (PCE) of Fireclay and High Alumina Refractory Materials¹

This standard is issued under the fixed designation C 24; the number immediately following the designation indicates the year of original adoption or, in the case of revision, the year of last revision. A number in parentheses indicates the year of last reapproval. A superscript epsilon (ϵ) indicates an editorial change since the last revision or reapproval.

This standard has been approved for use by agencies of the Department of Defense.

^{€1} NOTE—Editorial changes were made in Table 2 in October 1999.

1. Scope

1.1 This test method covers the determination of the Pyrometric Cone Equivalent (PCE) of fire clay, fireclay brick, high alumina brick, and silica fire clay refractory mortar by comparison of test cones with standard pyrometric cones under the conditions prescribed in this test method.

1.2 The values stated in inch-pound units are to be regarded as standard. The values given in parentheses are for information only.

1.3 *This standard does not purport to address all of the safety concerns, if any, associated with its use. It is the responsibility of the user of this standard to establish appropriate safety and health practices and determine the applicability of regulatory limitations prior to use.*

2. Referenced Documents

2.1 ASTM Standards:

C 71 Terminology Relating to Refractories²

E 11 Specification for Wire-Cloth Sieves for Testing Purposes³

E 220 Method for Calibration of Thermocouples by Comparison Techniques⁴

3. Terminology

3.1 *Definitions*—For definitions of terms used in this test method, see Terminology C 71.

4. Summary of Test Method

4.1 This test method consists of preparing a test cone from a refractory material and comparing its deformation end point to that of a standard pyrometric cone. The resultant PCE value is a measure of the refractoriness of the material.

4.2 Temperature equivalent tables for the standard cones

have been determined by the National Institute of Standards and Technology when subjected to both slow and rapid heating rates.

5. Significance and Use

5.1 The deformation and end point of a cone corresponds to a certain heat-work condition due to the effects of time, temperature, and atmosphere.

5.2 The precision of this test method is subject to many variables that are difficult to control. Therefore, an experienced operator may be necessary where PCE values are being utilized for specification purposes.

5.3 PCE values are used to classify fireclay and high alumina refractories.

5.4 This is an effective method of identifying fireclay variations, mining control, and developing raw material specifications.

5.5 Although not recommended, this test method is sometimes applied to materials other than fireclay and high alumina. Such practice should be limited to in-house laboratories and never be used for specification purposes.

6. Procedure

6.1 Preparation of Sample:

6.1.1 *Clay or Brick*—Crush the entire sample of fire clay or fireclay brick, in case the amount is small, by means of rolls or a jaw crusher to produce a particle size not larger than ¼ in. (6 mm). If the amount is large, treat a representative sample obtained by approved methods. Then mix the sample thoroughly and reduce the amount to about 250 g (0.5 lb) by quartering (see Note 1). Then grind this portion in an agate, porcelain, or hard steel mortar and reduce the amount again by quartering. The final size of the sample shall be 50 g and the fineness capable of passing an ASTM No. 70 (212- μ m) sieve⁵ (equivalent to a 65-mesh Tyler Standard Series). In order to avoid excessive reduction to fines, remove them frequently during the process of reduction by throwing the sample on the sieve and continuing the grinding of the coarser particles until all the sample passes through the sieve (see Note 2). Take

¹ This test method is under the jurisdiction of ASTM Committee C-8 on Refractories and is the direct responsibility of Subcommittee C08.07 on High Alumina, Silica, and Special Refractories.

Current edition approved July 28, 1989. Published November 1989. Originally issued as C 24 – 19 T. Last previous edition C 24 – 84 (1988).

² *Annual Book of ASTM Standards*, Vol 15.01.

³ *Annual Book of ASTM Standards*, Vol 14.02.

⁴ *Annual Book of ASTM Standards*, Vol 14.03.

⁵ Detailed requirements for this sieve are given in Specification E 11.

precautions to prevent contamination of the sample by steel particles from the sampling equipment during crushing or grinding.

NOTE 1—Take care during the crushing and grinding of the sample to prevent the introduction of magnetic material.

NOTE 2—The requirement to grind the coarser particles is particularly important for highly siliceous products; excessively fine grinding may reduce their PCE by as much as two cones.

6.1.2 *Silica Fire Clay* (see 3.1)—In the case of silica fire clay, test the sample obtained by approved methods as received without grinding or other treatment.

6.2 *Preparation of Test Cones:*

6.2.1 After preparing samples of unfired clays (Note 3), or of mixes containing appreciable proportions of raw clay, in accordance with 6.1.1, heat them in an oxidizing atmosphere in the temperature range from 1700 to 1800°F (925 to 980°C) for not less than 30 min.

NOTE 3—Some unfired clays bloat when they are formed into cones and are carried through the high-temperature heat treatment prescribed in 5.4.1 without preliminary calcining. The substances that cause bloating can, in most cases, be expelled by heating the clay samples before testing.

6.2.2 The clay sample may be given the heat treatment prescribed in 6.2.1 after it has been formed into a cone (see 6.2.3), but this procedure has been found not as effective as the treatment of the powdered material. If cones so prepared bloat during the PCE test, heat a portion of the original sample in its powdered condition as prescribed in 6.2.1 and then retest it.

6.2.3 Thoroughly mix the dried sample, and after the addition of sufficient dextrine, glue, gum tragacanth, or other alkali-free organic binder and water, form it in a metal mold into test cones in the shape of a truncated trigonal pyramid with its base at a small angle to the trigonal axis, and in accordance with dimensions shown in Fig. 1. In forming the test cone use the mold shown in Fig. 2.

6.3 *Mounting:*

6.3.1 Mount both the test cones and the Standard Pyrometric Cones on plaques of refractory material that have a composition that will not affect the fusibility of the cones (see Note 4). Mount both test and PCE cones with the base embedded so that the length of the sloping face of the cone above the plaque shall be $\frac{15}{16}$ in. (24 mm) and the face of the cone (about which bending takes place) shall be inclined at an angle of 82° with the horizontal. Arrange the test cones with respect to the PCE cones as shown in Fig. 3, that is, alternate the test cones with the PCE cones in so far as is practical (see Note 5). The plaque may be any convenient size and shape and may be biscuited before using, if desired.

NOTE 4—A satisfactory cone plaque mix consists of 85 % fused alumina and 15 % plastic refractory clay. For tests that will not go above Cone 34, the plastic refractory clay may be increased to 25 % and the alumina may be replaced with brick grog containing over 70 % alumina. The alumina or grog should be ground to pass an ASTM No. 60 (250- μ m) sieve (equivalent to a 60-mesh Tyler Standard Series), and the PCE of the refractory plastic clay should be not lower than Cone 32.

NOTE 5—The number of cones and their mounting facing inward as shown in Fig. 3 is typical for gas-fired furnaces of relatively large dimensions and gases moving at high velocity. The practical bore of the muffle tubes in most electric furnaces does not permit cone pats of this size. The static atmosphere prevailing permits the cones being mounted to

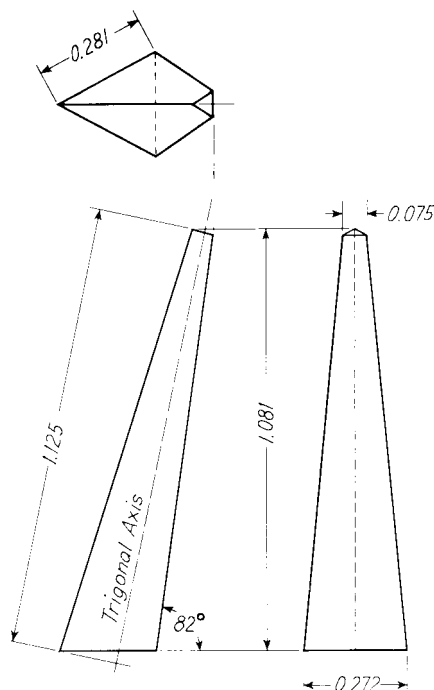

NOTE 1—Dimensions are in inches.

SI Equivalents

| in. | mm |
|-------|-------|
| 0.075 | 1.90 |
| 0.272 | 6.91 |
| 0.281 | 7.14 |
| 1.081 | 27.46 |
| 1.125 | 28.58 |

FIG. 1 Standard Pyrometric Test Cone

face outward, if so desired.

6.4 *Heating:*

6.4.1 Perform the heating in a suitable furnace, operating with an oxidizing atmosphere, at rates to conform to the following requirements (see Note 6 and Note 7). It is advisable, but not mandatory that the furnace temperature be controlled with a calibrated⁶ thermocouple or radiation pyrometer connected to a program-controlled recorder.

6.4.1.1 For PCE tests expected to have an end point of PCE Cone 12 or above, but not exceeding Cone 26, heat at the rate prescribed in Table 1.

6.4.1.2 For PCE tests expected to have an end point above Cone 26, heat at the rate prescribed in Table 2.

NOTE 6—The heating rate through the cone series in both Table 1 and 2 is at 270°F (150°C)/h.

NOTE 7—Following a test run, the cone pat may be removed at 1830°F (1000°C) and a new pat may be put in without cooling the furnace to below red heat. The time interval to bring the furnace, using Table 1, up to Cone 12 shall be not less than 20 min, and using Table 2, the time interval up to Cone 20 shall be not less than 25 min.

6.4.2 The furnace atmosphere shall contain a minimum of 0.5 % oxygen with 0 % combustibles. Make provisions to

⁶ Method E 220 specifies calibration procedures for thermocouples.