



Designation: C 824 – 91 (Reapproved 1996)

AMERICAN SOCIETY FOR TESTING AND MATERIALS  
100 Barr Harbor Dr., West Conshohocken, PA 19428  
Reprinted from the Annual Book of ASTM Standards. Copyright ASTM

## Standard Practice for Specimen Preparation for Determination of Linear Thermal Expansion of Vitreous Glass Enamels and Glass Enamel Frits by the Dilatometer Method<sup>1</sup>

This standard is issued under the fixed designation C 824; the number immediately following the designation indicates the year of original adoption or, in the case of revision, the year of last revision. A number in parentheses indicates the year of last reapproval. A superscript epsilon ( $\epsilon$ ) indicates an editorial change since the last revision or reapproval.

### 1. Scope

1.1 This practice covers the preparation of vitreous glass enamels and glass enamel frit specimens for the measurement of linear thermal expansion using Test Method E 228.

1.2 The values stated in SI units are to be regarded as the standard. The values given in parentheses are for information only.

1.3 *This standard does not purport to address all of the safety concerns, if any, associated with its use. It is the responsibility of the user of this standard to establish appropriate safety and health practices and determine the applicability of regulatory limitations prior to use.* For specific hazard statements, see Section 6.

### 2. Referenced Documents

2.1 *ASTM Standards:*

E 228 Test Method for Linear Thermal Expansion of Solid Materials With a Vitreous Silica Dilatometer<sup>2</sup>

### 3. Significance and Use

3.1 The dilatometer method of measuring linear thermal expansion of vitreous glass enamels and glass enamel frits has the advantage of simplicity, lends itself to automatic, self-recording arrangements, and requires test specimens of simple configuration.

### 4. Apparatus

4.1 *Powder Pressing Die*, whose top and bottom sections are free to move such that density variations within the bar are minimized (see Fig. 1).

4.2 *Hydraulic Press.*

4.3 *Furnace*, for firing test specimen, electrically heated and controlled to a minimum rate of heating of 1°C/min from room temperature to the maximum temperature of the test. It shall be so designed that the temperature variation over the length of the test specimen shall be less than 2°C during the entire range of heating.

<sup>1</sup> This practice is under the jurisdiction of ASTM Committee C-14 on Glass and Glass Products, and is the direct responsibility of Subcommittee C14.10 on glass Decoration.

Current edition approved Sept. 15, 1991. Published January 1992. Originally published as C 824 – 76. Last previous edition C 824 – 81 (1988).

<sup>2</sup> *Annual Book of ASTM Standards*, Vol 14.02.

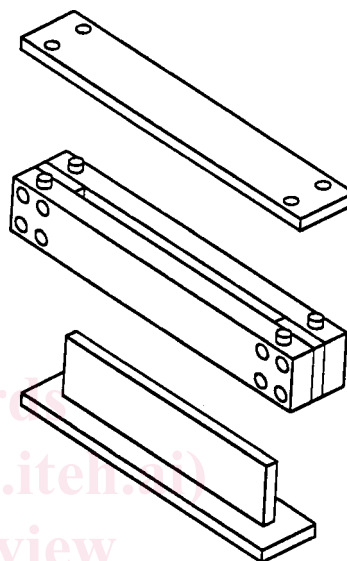

NOTE 1—Material: No. 316 stainless steel.

FIG. 1 Powder Pressing Die

4.4 *Scale or Caliper*, capable of measuring the length of the test specimen to an accuracy of 0.1 %.

### 5. Reagents and Materials

5.1 *Hydroxypropyl Cellulose Solution in Water* (1 weight% ).

5.2 *Powder Sample.*

### 6. Hazards

6.1 Appropriate ventilation should be provided when handling powdered frits or enamels containing toxic ingredients.

6.2 Ingestion or inhalation of test materials should be avoided. Protective clothing such as gloves, respirators, etc., may be advisable. If ingestion occurs, seek medical attention immediately.

6.3 Caution should be exercised when placing specimens in furnaces. Tongs and insulated gloves should be used. To avoid accidental contact and serious thermal burns, care should be taken to guard hot-fired specimens while they are being cooled.

### 7. Test Specimen Preparation

7.1 Collect vitreous glass enamel or glass enamel frit