

INTERNATIONAL STANDARD



Information technology – Small computer system interface (SCSI) –
Part 153: Serial attached SCSI - 2.1 (SAS-2.1)
ITeH STANDARD PREVIEW
(standards.iteh.ai)

[ISO/IEC 14776-153:2015](#)

<https://standards.iteh.ai/catalog/standards/sist/7c53e8c5-515c-4a8b-b284-4b0401d2a5c3/iso-iec-14776-153-2015>



THIS PUBLICATION IS COPYRIGHT PROTECTED
Copyright © 2015 ISO/IEC, Geneva, Switzerland

All rights reserved. Unless otherwise specified, no part of this publication may be reproduced or utilized in any form or by any means, electronic or mechanical, including photocopying and microfilm, without permission in writing from either IEC or IEC's member National Committee in the country of the requester. If you have any questions about ISO/IEC copyright or have an enquiry about obtaining additional rights to this publication, please contact the address below or your local IEC member National Committee for further information.

IEC Central Office
3, rue de Varembe
CH-1211 Geneva 20
Switzerland

Tel.: +41 22 919 02 11
Fax: +41 22 919 03 00
info@iec.ch
www.iec.ch

About the IEC

The International Electrotechnical Commission (IEC) is the leading global organization that prepares and publishes International Standards for all electrical, electronic and related technologies.

About IEC publications

The technical content of IEC publications is kept under constant review by the IEC. Please make sure that you have the latest edition, a corrigenda or an amendment might have been published.

IEC Catalogue - webstore.iec.ch/catalogue

The stand-alone application for consulting the entire bibliographical information on IEC International Standards, Technical Specifications, Technical Reports and other documents. Available for PC, Mac OS, Android Tablets and iPad.

IEC publications search - www.iec.ch/searchpub

The advanced search enables to find IEC publications by a variety of criteria (reference number, text, technical committee,...). It also gives information on projects, replaced and withdrawn publications.

IEC Just Published - webstore.iec.ch/justpublished

Stay up to date on all new IEC publications. Just Published details all new publications released. Available online and also once a month by email.

Electropedia - www.electropedia.org

The world's leading online dictionary of electronic and electrical terms containing more than 30 000 terms and definitions in English and French, with equivalent terms in 15 additional languages. Also known as the International Electrotechnical Vocabulary (IEV) online.

IEC Glossary - std.iec.ch/glossary

More than 60 000 electrotechnical terminology entries in English and French extracted from the Terms and Definitions clause of IEC publications issued since 2002. Some entries have been collected from earlier publications of IEC TC 37, 77, 86 and CISPR.

IEC Customer Service Centre - webstore.iec.ch/csc

If you wish to give us your feedback on this publication or need further assistance, please contact the Customer Service Centre: csc@iec.ch.

INTERNATIONAL STANDARDS (standards) IEC (IEC) ISO/IEC 14774-153:2015
https://standards.iec.ch/catalog/standards/4b0401d2a5c3/iso-iec-14774-153-2015
4b0401d2a5c3/iso-iec-14774-153-2015

INTERNATIONAL STANDARD



Information technology – Small computer system interface (SCSI) –
Part 153: Serial attached SCSI - 2.1 (SAS-2.1)

<https://standards.iteh.ai/catalog/standards/sist/7c53e8c5-515c-4a8b-b284-4b0401d2a5c3/iso-iec-14776-153-2015>

INTERNATIONAL
ELECTROTECHNICAL
COMMISSION

ICS 35.200

ISBN 978-2-8322-2204-1

Warning! Make sure that you obtained this publication from an authorized distributor.

CONTENTS

FOREWORD	10
INTRODUCTION	12
General	12
SCSI standards family	12
1 Scope	14
2 Normative references	14
3 Terms, definitions, symbols, abbreviations, keywords, and conventions	16
3.1 Terms and definitions	16
3.2 Symbols and abbreviations	28
3.2.1 Abbreviations	28
3.2.2 Units	30
3.2.3 Symbols	30
3.2.4 Mathematical operators	31
3.3 Keywords	32
3.4 Editorial conventions	33
4 General	34
4.1 Physical links and phys	34
4.2 Phy test functions	34
5 Physical layer	35
5.1 Physical layer overview	35
5.2 Conventions for defining maximum limits for S-parameters	35
5.3 Compliance points	36
5.4 Interconnects	45
5.4.1 SATA connectors and cable assemblies	45
5.4.2 SAS connectors and cables	46
5.4.3 Connectors	49
5.4.4 Cable assemblies	94
5.4.5 Backplanes	118
5.5 TxRx connection characteristics	119
5.5.1 TxRx connection characteristics overview	119
5.5.2 TxRx connection general characteristics	120
5.5.3 Passive TxRx connection S-parameter limits	120
5.5.4 Passive TxRx connection characteristics for untrained 1.5 Gbit/s, 3 Gbit/s, and 6 Gbit/s	122
5.5.5 Passive TxRx connection characteristics for trained 1.5 Gbit/s, 3 Gbit/s, and 6 Gbit/s	123
5.5.6 TxRx connection characteristics for active cable assemblies	124
5.6 Test loads	126
5.6.1 Test loads overview	126
5.6.2 Zero-length test load	127
5.6.3 TCTF test load	129
5.6.4 Low-loss TCTF test load	133
5.6.5 Reference transmitter test load	134
5.7 Transmitter device and receiver device electrical characteristics	139

iteh STANDARD PREVIEW
(standards.iteh.ai)

[ISO/IEC 14776-153:2015](https://standards.iteh.ai/catalog/standards/sist/7c53e8c5-515c-4a8b-b284-4b0401d2a533/iso-iec-14776-153-2015)

[https://standards.iteh.ai/catalog/standards/sist/7c53e8c5-515c-4a8b-b284-](https://standards.iteh.ai/catalog/standards/sist/7c53e8c5-515c-4a8b-b284-4b0401d2a533/iso-iec-14776-153-2015)

[4b0401d2a533/iso-iec-14776-153-2015](https://standards.iteh.ai/catalog/standards/sist/7c53e8c5-515c-4a8b-b284-4b0401d2a533/iso-iec-14776-153-2015)

- 5.7.1 General electrical characteristics 139
- 5.7.2 Transmitter device and receiver device transients..... 139
- 5.7.3 Eye masks and the jitter transfer function (JTF) 140
- 5.7.4 Transmitter device characteristics 144
- 5.7.5 Receiver device characteristics 155
- 5.7.6 Spread spectrum clocking (SSC) 170
- 5.7.7 Non-tracking clock architecture 173
- 5.8 READY LED signal electrical characteristics 173
- 5.9 Out of band (OOB) signals 175
 - 5.9.1 OOB signals overview 175
 - 5.9.2 Transmitting OOB signals 176
 - 5.9.3 Receiving OOB signals 178
 - 5.9.4 Transmitting the SATA port selection signal 179
- Annex A (normative) – Jitter tolerance pattern (JTPAT) 180
- Annex B (normative) – SASWDP 182
- Annex C (informative) – StatEye 190
- Annex D (informative) – Signal performance measurements 232
- Annex E (informative) – Description of the included Touchstone models 253
- Annex F (informative) – Mini SAS 4x active cable assembly power supply and voltage detection circuitry 259
- Annex G (informative) – SAS icons 260
- Bibliography 262

ITeC STANDARD PREVIEW

(standards.itec.ai)

[ISO/IEC 14776-153:2015](https://standards.itec.ai/catalog/standards/sist/7c53c8c5-515c-4a8b-b284-4b0401d2a5c3/iso-iec-14776-153-2015)

[https://standards.itec.ai/catalog/standards/sist/7c53c8c5-515c-4a8b-b284-](https://standards.itec.ai/catalog/standards/sist/7c53c8c5-515c-4a8b-b284-4b0401d2a5c3/iso-iec-14776-153-2015)

[4b0401d2a5c3/iso-iec-14776-153-2015](https://standards.itec.ai/catalog/standards/sist/7c53c8c5-515c-4a8b-b284-4b0401d2a5c3/iso-iec-14776-153-2015)

Figure 1 – SCSI document relationships	12
Figure 2 – ATA document relationships	13
Figure 3 – Physical links and phys	34
Figure 4 – Maximum limits for S-parameters definitions	36
Figure 5 – External cable assembly CT compliance points and CR compliance points	38
Figure 6 – Backplane with SAS Drive connector IT compliance points and IR compliance points	39
Figure 7 – Backplane with SAS Drive connector compliance points with SATA phy attached	40
Figure 8 – SAS multilane internal cable assembly IT compliance points and IR compliance points	41
Figure 9 – SAS multilane internal cable assembly and backplane IT compliance points and IR compliance points	42
Figure 10 – SAS multilane internal cable assembly and backplane IT compliance points and IR compliance points with SATA device attached	43
Figure 11 – SAS Drive cable assembly IT compliance points and IR compliance points	44
Figure 12 – SATA connectors and cables	45
Figure 13 – SAS Drive cable environments	46
Figure 14 – SAS Drive backplane environment	46
Figure 15 – SAS external cable environment	47
Figure 16 – SAS internal symmetric cable environment - controller to backplane	47
Figure 17 – SAS internal symmetric cable environment - controller to controller	47
Figure 18 – SAS internal controller-based fanout cable environment	48
Figure 19 – SAS internal backplane-based fanout cable environment	48
Figure 20 – SAS Drive plug connector	51
Figure 21 – Single-port SAS Drive cable receptacle connector	52
Figure 22 – Dual-port SAS Drive cable receptacle connector	52
Figure 23 – SAS Drive backplane receptacle connector	53
Figure 24 – Micro SAS plug connector	55
Figure 25 – Micro SAS receptacle connector	55
Figure 26 – SAS 4i cable receptacle connector	57
Figure 27 – SAS 4i plug connector	57
Figure 28 – Mini SAS 4i cable plug connector	60
Figure 29 – Mini SAS 4i receptacle connector	60
Figure 30 – Mini SAS HD 4i cable plug connector	63
Figure 31 – Mini SAS HD 8i cable plug connector	64
Figure 32 – Mini SAS HD 4i receptacle connector	65
Figure 33 – Mini SAS HD 8i receptacle connector	66
Figure 34 – Mini SAS 4x cable plug connector	69
Figure 35 – Mini SAS 4x cable plug connector for untrained 1.5 Gbit/s and 3 Gbit/s that attaches to an enclosure out port or an enclosure in port	70
Figure 36 – Mini SAS 4x cable plug connector for untrained 1.5 Gbit/s and 3 Gbit/s that attaches to an enclosure out port	71
Figure 37 – Mini SAS 4x cable plug connector for untrained 1.5 Gbit/s and 3 Gbit/s that attaches to an enclosure in port	71
Figure 38 – Mini SAS 4x cable plug connector for trained 1.5 Gbit/s and 3 Gbit/s that attaches to an enclosure out port or an enclosure in port	72
Figure 39 – Mini SAS 4x cable plug connector for trained 1.5 Gbit/s, 3 Gbit/s, and 6 Gbit/s that attaches to an enclosure out port	72

Figure 40 – Mini SAS 4x cable plug connector for trained 1.5 Gbit/s, 3 Gbit/s, and 6 Gbit/s that attaches to an enclosure in port	73
Figure 41 – Mini SAS 4x active cable plug connector that attaches to an enclosure out port or an enclosure in port	73
Figure 42 – Mini SAS 4x active cable plug connector that attaches to an enclosure out port	74
Figure 43 – Mini SAS 4x active cable plug connector that attaches to an enclosure in port	74
Figure 44 – Mini SAS 4x receptacle connector	75
Figure 45 – Mini SAS 4x receptacle connector - end device or enclosure universal port for untrained 1.5 Gbit/s and 3 Gbit/s	76
Figure 46 – Mini SAS 4x receptacle connector - enclosure out port for untrained 1.5 Gbit/s and 3 Gbit/s	77
Figure 47 – Mini SAS 4x receptacle connector - enclosure in port for untrained 1.5 Gbit/s and 3 Gbit/s	77
Figure 48 – Mini SAS 4x receptacle connector - end device or enclosure universal port for trained 1.5 Gbit/s, 3 Gbit/s, and 6 Gbit/s and for untrained 1.5 Gbit/s and 3 Gbit/s ..	78
Figure 49 – Mini SAS 4x receptacle connector - enclosure out port for trained 1.5 Gbit/s, 3 Gbit/s, and 6 Gbit/s and for untrained 1.5 Gbit/s and 3 Gbit/s	78
Figure 50 – Mini SAS 4x receptacle connector - enclosure in port for trained 1.5 Gbit/s, 3 Gbit/s, and 6 Gbit/s and for untrained 1.5 Gbit/s and 3 Gbit/s	79
Figure 51 – Mini SAS 4x active receptacle connector - end device or enclosure universal port ..	79
Figure 52 – Mini SAS 4x active receptacle connector - enclosure out port	80
Figure 53 – Mini SAS 4x active receptacle connector - enclosure in port	80
Figure 54 – Mini SAS HD 4x cable plug connector	84
Figure 55 – Mini SAS HD 8x cable plug connector	85
Figure 56 – Mini SAS HD 4x receptacle connector	86
Figure 57 – Mini SAS HD 8x receptacle connector	87
Figure 58 – Mini SAS HD 16x receptacle connector	87
Figure 59 – QSFP+ cable plug connector	90
Figure 60 – QSFP+ receptacle connector	91
Figure 61 – Single-port SAS Drive cable assembly	94
Figure 62 – Dual-port SAS Drive cable assembly	95
Figure 63 – SAS internal symmetric cable assembly - SAS 4i	96
Figure 64 – SAS internal symmetric cable assembly - Mini SAS 4i	97
Figure 65 – SAS internal symmetric cable assembly - Mini SAS HD 4i	98
Figure 66 – SAS internal symmetric cable assembly - Mini SAS HD 8i	99
Figure 67 – SAS internal symmetric cable assembly - SAS 4i to Mini SAS 4i with vendor specific sidebands	100
Figure 68 – SAS internal symmetric cable assembly - SAS 4i controller to Mini SAS 4i backplane with SGPIO	101
Figure 69 – SAS internal symmetric cable assembly - Mini SAS 4i controller to SAS 4i backplane with SGPIO	102
Figure 70 – SAS internal symmetric cable assembly - Mini SAS 4i to Mini SAS HD 4i	103
Figure 71 – SAS internal controller-based fanout cable assembly - SAS 4i	105
Figure 72 – SAS internal controller-based fanout cable assembly - Mini SAS 4i	106
Figure 73 – SAS internal controller-based fanout cable assembly - Mini SAS HD 4i	107
Figure 74 – SAS internal backplane-based fanout cable assembly - SAS 4i	108
Figure 75 – SAS internal backplane-based fanout cable assembly - Mini SAS 4i	109

Figure 76 – SAS internal backplane-based fanout cable assembly - Mini SAS HD 4i	110
Figure 77 – Mini SAS 4x external cable assembly	111
Figure 78 – Mini SAS 4x active external cable assembly	112
Figure 79 – SAS external cable assembly with Mini SAS 4x cable plug connectors	113
Figure 80 – SAS external cable assembly - Mini SAS HD 4x	114
Figure 81 – SAS external cable assembly with Mini SAS HD 4x cable plug connectors	115
Figure 82 – SAS external cable assembly - Mini SAS HD 8x	116
Figure 83 – SAS external cable assembly with Mini SAS HD 8x cable plug connectors	117
Figure 84 – SAS external cable assembly - Mini SAS HD 4x to Mini SAS 4x	118
Figure 85 – Passive TxRx connection $ S_{DD22} $, $ S_{CD22} $, $ S_{CD21} $, and NEXT limits	122
Figure 86 – Example passive TxRx connection compliance testing for trained 1.5 Gbit/s, 3 Gbit/s, and 6 Gbit/s	123
Figure 87 – Active cable S-parameter limits	126
Figure 88 – Zero-length test load for transmitter device compliance point	127
Figure 89 – Zero-length test load for receiver device compliance point	127
Figure 90 – Zero-length test load $ S_{DD21}(f) $ requirements	128
Figure 91 – TCTF test load	129
Figure 92 – TCTF test load $ S_{DD21}(f) $ and ISI loss requirements at IT for untrained 3 Gbit/s ...	130
Figure 93 – TCTF test load $ S_{DD21}(f) $ and ISI loss requirements at CT for untrained 3 Gbit/s ..	131
Figure 94 – TCTF test load $ S_{DD21}(f) $ and ISI loss requirements at IT for untrained 1.5 Gbit/s	132
Figure 95 – TCTF test load $ S_{DD21}(f) $ and ISI loss requirements at CT for untrained 1.5 Gbit/s	133
Figure 96 – Low-loss TCTF test load	133
Figure 97 – Low-loss TCTF test load $ S_{DD21}(f) $ and ISI loss requirements	134
Figure 98 – Reference transmitter test load $ S_{DD21}(f) $ up to 6 GHz	135
Figure 99 – Reference transmitter test load pulse response	136
Figure 100 – Reference transmitter test load impulse response	137
Figure 101 – Reference transmitter test load D24.3 response	138
Figure 102 – Transmitter device transient test circuit	140
Figure 103 – Receiver device transient test circuit	140
Figure 104 – Transmitter device eye mask	142
Figure 105 – Receiver device eye mask	142
Figure 106 – Deriving a receiver device jitter tolerance eye mask for untrained 1.5 Gbit/s and 3 Gbit/s	143
Figure 107 – Transmitter device common mode voltage limit	149
Figure 108 – Transmitter device $ S_{CC22} $, $ S_{DD22} $, and $ S_{CD22} $ limits	151
Figure 109 – Reference transmitter device	152
Figure 110 – Reference transmitter device termination S-parameters	153
Figure 111 – Transmitter equalization measurement	154
Figure 112 – Applied SJ for untrained 1.5 Gbit/s and 3 Gbit/s	160
Figure 113 – Receiver device $ S_{CC11} $, $ S_{DD11} $, and $ S_{CD11} $ limits	162
Figure 114 – Reference receiver device	163
Figure 115 – Reference receiver device termination S-parameters	164
Figure 116 – Stressed receiver device jitter tolerance test block diagram	165
Figure 117 – Stressed receiver device jitter tolerance test D24.3 eye opening	167
Figure 118 – Applied SJ for trained 1.5 Gbit/s, 3 Gbit/s, and 6 Gbit/s without SSC support	168

Figure 119 – Applied SJ for trained 1.5 Gbit/s, 3 Gbit/s, and 6 Gbit/s with SSC support	169
Figure 120 – Center-spreading tolerance buffer	173
Figure 121 – OOB signal transmission	177
Figure 122 – SATA port selection signal	179
Figure C.1 – StatEye result	230
Figure D.1 – A simple physical link	232
Figure D.2 – Transmitter device details	233
Figure D.3 – Receiver device details	234
Figure D.4 – De-embedding of connectors in test fixtures	236
Figure D.5 – Measurement conditions for signal output at the transmitter device	237
Figure D.6 – Transmitter device signal output measurement test fixture details	237
Figure D.7 – Measurement conditions for signal tolerance at the transmitter device	238
Figure D.8 – Calibration of test fixture for signal tolerance at the transmitter device	238
Figure D.9 – Measurement conditions for signal output at the receiver device	239
Figure D.10 – Measurement conditions for signal tolerance at the receiver device	239
Figure D.11 – Calibration of test fixture for signal tolerance at the receiver device	240
Figure D.12 – S-parameter port naming conventions	241
Figure D.13 – Four single-ended port or two differential port element	242
Figure D.14 – S-parameters for single-ended and differential systems	242
Figure D.15 – Measurement conditions for S_{22} at the transmitter device connector	243
Figure D.16 – Measurement conditions for S_{11} at the receiver device connector	244
Figure D.17 – Measurement conditions for S_{11} at IT or CT	245
Figure D.18 – Measurement conditions for S_{22} at IR or CR	246
Figure E.1 – Reference transmitter device and reference receiver device termination circuit model	253
Figure E.2 – Generic return loss circuit model	255
Figure E.3 – Generic return loss model $ S_{11} $	256
Figure E.4 – Reference transmitter test load measurement setup	257
Figure E.5 – Reference transmitter test load $ S_{DD21}(f) $ up to 20 GHz	258
Figure F.1 – Dual comparator design for active cable assembly detection	259
Figure G.1 – SAS primary icon	260
Figure G.2 – SAS alternate icon	260
Figure G.3 – SAS alternate icon with SAS letters	261

Table 1 – Numbering conventions	33
Table 2 – Compliance points	37
Table 3 – Connectors	49
Table 4 – Connector categories	51
Table 5 – SAS Drive connector pin assignments	54
Table 6 – Micro SAS connector pin assignments	56
Table 7 – Controller SAS 4i connector pin assignments and physical link usage	58
Table 8 – Backplane SAS 4i connector pin assignments and physical link usage	59
Table 9 – Controller Mini SAS 4i connector pin assignments and physical link usage	61
Table 10 – Backplane Mini SAS 4i connector pin assignments and physical link usage	62
Table 11 – Controller Mini SAS HD 4i connector pin assignments and physical link usage	66
Table 12 – Backplane Mini SAS HD 4i connector pin assignments and physical link usage	67
Table 13 – Mini SAS 4x cable plug connector and Mini SAS 4x active cable plug connector icons, key slot positions, and key positions	70
Table 14 – Mini SAS 4x receptacle connector icons, key positions, and key slot positions	76
Table 15 – Mini SAS 4x connector pin assignments and physical link usage	81
Table 16 – Mini SAS 4x active connector pin assignments and physical link usage	82
Table 17 – Mini SAS 4x active cable supplied power requirements	83
Table 18 – Mini SAS HD 4x connector pin assignments and physical link usage	88
Table 19 – Management interface connection requirements	89
Table 20 – QSFP+ connector pin assignments	92
Table 21 – TxRx connection general characteristics	120
Table 22 – Maximum limits for S-parameters of the passive TxRx connection	121
Table 23 – Passive TxRx connection characteristics for trained 6 Gbit/s	123
Table 24 – Active cable assembly output electrical characteristics for trained 6 Gbit/s	124
Table 25 – Maximum limits for S-parameters for active cable assemblies	125
Table 26 – General electrical characteristics	139
Table 27 – JTF parameters	141
Table 28 – Transmitter device general electrical characteristics	144
Table 29 – Transmitter device termination characteristics	145
Table 30 – Transmitter device signal output characteristics for untrained 1.5 Gbit/s and 3 Gbit/s as measured with the zero-length test load at IT and CT	145
Table 31 – Transmitter device signal output characteristics for untrained 1.5 Gbit/s and 3 Gbit/s as measured with each test load at IT and CT	147
Table 32 – Transmitter device signal output characteristics for trained 1.5 Gbit/s, 3 Gbit/s, and 6 Gbit/s at IT and CT	148
Table 33 – Transmitter device common mode voltage limit characteristics	149
Table 34 – Maximum limits for S-parameters at IT _s or CT _s	150
Table 35 – Recommended transmitter device settings at IT and CT	151
Table 36 – Reference transmitter device characteristics at IT and CT	152
Table 37 – Transmitter device signal output characteristics for OOB signals	155
Table 38 – Receiver device general electrical characteristics	156
Table 39 – Receiver device termination characteristics	157
Table 40 – Delivered signal characteristics for untrained 1.5 Gbit/s and 3 Gbit/s as measured with the zero length test load at IR and CR	158
Table 41 – Maximum delivered jitter for untrained 1.5 Gbit/s and 3 Gbit/s at IR and CR	159

Table 42 – Receiver device jitter tolerance for untrained 1.5 Gbit/s and 3 Gbit/s at IR and CR	160
Table 43 – f_{\min} , f_c , and f_{\max} for untrained 1.5 Gbit/s and 3 Gbit/s	161
Table 44 – Delivered signal characteristics for trained 1.5 Gbit/s, 3 Gbit/s, and 6 Gbit/s at IR and CR	161
Table 45 – Maximum limits for S-parameters at IR or CR	162
Table 46 – Stressed receiver device jitter tolerance test characteristics	166
Table 47 – Number of bits received per number of errors for desired BER	167
Table 48 – f_{\min} , f_c , and f_{\max} for trained 1.5 Gbit/s, 3 Gbit/s, and 6 Gbit/s without SSC support	169
Table 49 – f_{\min} , f_c , f_{\max} , and SJ_{ff} for trained 1.5 Gbit/s, 3 Gbit/s, and 6 Gbit/s with SSC support	169
Table 50 – Delivered signal characteristics for OOB signals	170
Table 51 – SSC modulation types	170
Table 52 – SAS phy transmitter SSC modulation types	171
Table 53 – Expander phy transmitter SSC modulation types	171
Table 54 – Receiver SSC modulation types tolerance	172
Table 55 – Expander device center-spreading tolerance buffer	172
Table 56 – Output characteristics of the READY LED signal	174
Table 57 – OOB signal timing specifications	175
Table 58 – OOB signal transmitter device requirements	176
Table 59 – OOB signal receiver device burst time detection requirements	178
Table 60 – OOB signal receiver device idle time detection requirements	178
Table 61 – OOB signal receiver device negation time detection requirements	178
Table 62 – SATA port selection signal transmitter device requirements	179
Table A.1 – JTPAT for RD+	180
Table A.2 – JTPAT for RD-	181
Table D.1 – High frequency jitter source amplitudes	249
Table D.2 – Low frequency jitter source calibration amplitudes.....	251
Table D.3 – Low frequency jitter attenuation targets	252

STANDARD PREVIEW
(standardsiteh.ai)

ISO/IEC 14776-153:2015

[https://standards.iteh.ai/catalog/standards/sist/7c53e8c5-515c-4a8b-b284-](https://standards.iteh.ai/catalog/standards/sist/7c53e8c5-515c-4a8b-b284-4b0401d2a5c3/iso-iec-14776-153-2015)

[4b0401d2a5c3/iso-iec-14776-153-2015](https://standards.iteh.ai/catalog/standards/sist/7c53e8c5-515c-4a8b-b284-4b0401d2a5c3/iso-iec-14776-153-2015)

INFORMATION TECHNOLOGY – SMALL COMPUTER SYSTEM INTERFACE (SCSI) –

Part 153: SERIAL ATTACHED SCSI - 2.1 (SAS-2.1)

FOREWORD

- 1) ISO (the International Organization for Standardization) and IEC (the International Electrotechnical Commission) form the specialized system for worldwide standardization. National bodies that are members of ISO or IEC participate in the development of International Standards through technical committees established by the respective organization to deal with particular fields of technical activity. ISO and IEC technical committees collaborate in fields of mutual interest. Other international organizations, governmental and non-governmental, in liaison with ISO and IEC, also take part in the work. In the field of information technology, ISO and IEC have established a joint technical committee, ISO/IEC JTC 1.
- 2) The formal decisions or agreements of IEC and ISO on technical matters express, as nearly as possible, an international consensus of opinion on the relevant subjects since each technical committee has representation from all interested IEC National Committees and ISO member bodies.
- 3) IEC, ISO and ISO/IEC publications have the form of recommendations for international use and are accepted by IEC National Committees and ISO member bodies in that sense. While all reasonable efforts are made to ensure that the technical content of IEC, ISO and ISO/IEC publications is accurate, IEC or ISO cannot be held responsible for the way in which they are used or for any misinterpretation by any end user.
- 4) In order to promote international uniformity, IEC National Committees and ISO member bodies undertake to apply IEC, ISO and ISO/IEC publications transparently to the maximum extent possible in their national and regional publications. Any divergence between any ISO, IEC or ISO/IEC publication and the corresponding national or regional publication should be clearly indicated in the latter.
- 5) ISO and IEC do not provide any attestation of conformity. Independent certification bodies provide conformity assessment services and, in some areas, access to IEC marks of conformity. ISO or IEC are not responsible for any services carried out by independent certification bodies.
- 6) All users should ensure that they have the latest edition of this publication.
- 7) No liability shall attach to IEC or ISO or its directors, employees, servants or agents including individual experts and members of their technical committees and IEC National Committees or ISO member bodies for any personal injury, property damage or other damage of any nature whatsoever, whether direct or indirect, or for costs (including legal fees) and expenses arising out of the publication of, use of, or reliance upon, this ISO/IEC publication or any other IEC, ISO or ISO/IEC publications.
- 8) Attention is drawn to the normative references cited in this publication. Use of the referenced publications is indispensable for the correct application of this publication.
- 9) Attention is drawn to the possibility that some of the elements of this ISO/IEC publication may be the subject of patent rights. ISO and IEC shall not be held responsible for identifying any or all such patent rights.

International Standard ISO/IEC 14776-153 was prepared by subcommittee 25: Interconnection of information technology equipment, of ISO/IEC joint technical committee 1: Information technology.

The list of all currently available parts of the ISO/IEC 14776 series, under the general title *Information technology – Small computer system interface (SCSI)*, can be found on the IEC web site.

This International Standard has been approved by vote of the member bodies and the voting results may be obtained from the address given on the second title page.

This publication has been drafted in accordance with the ISO/IEC Directives, Part 2, as far as is practicable.

IMPORTANT – The 'colour inside' logo on the cover page of this publication indicates that it contains colours which are considered to be useful for the correct understanding of its contents. Users should therefore print this document using a colour printer.

**iTeh STANDARD PREVIEW
(standards.iteh.ai)**

[ISO/IEC 14776-153:2015](https://standards.iteh.ai/catalog/standards/sist/7c53e8c5-515c-4a8b-b284-4b0401d2a5c3/iso-iec-14776-153-2015)

<https://standards.iteh.ai/catalog/standards/sist/7c53e8c5-515c-4a8b-b284-4b0401d2a5c3/iso-iec-14776-153-2015>

INTRODUCTION

General

The SCSI family of standards provides for many different transport protocols that define the rules for exchanging information between different SCSI devices. This standard specifies the functional requirements for the Serial Attached SCSI (SAS) physical interconnect, which is compatible with the Serial ATA physical interconnect. The SAS Protocol Layer (SPL) standard documents the SAS protocol layer corresponding to the Serial Attached SCSI - 2.1 (SAS-2.1) and beyond, defining the rules for exchanging information between SCSI devices using a serial interconnect. Other SCSI transport protocol standards define the rules for exchanging information between SCSI devices using other interconnects.

SCSI standards family

Figure 1 shows the relationship of this standard to the other standards and related projects in the SCSI family of standards.

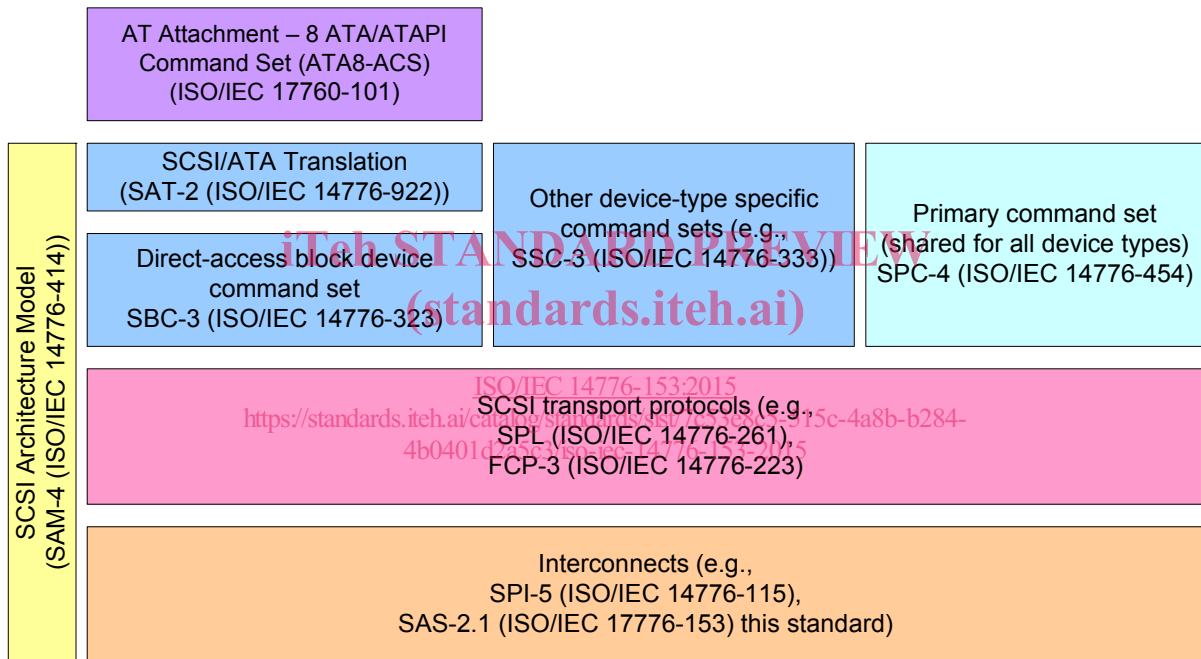

Figure 1 — SCSI document relationships

Figure 2 shows the relationship of this standard to other standards and related projects in the ATA family of standards.

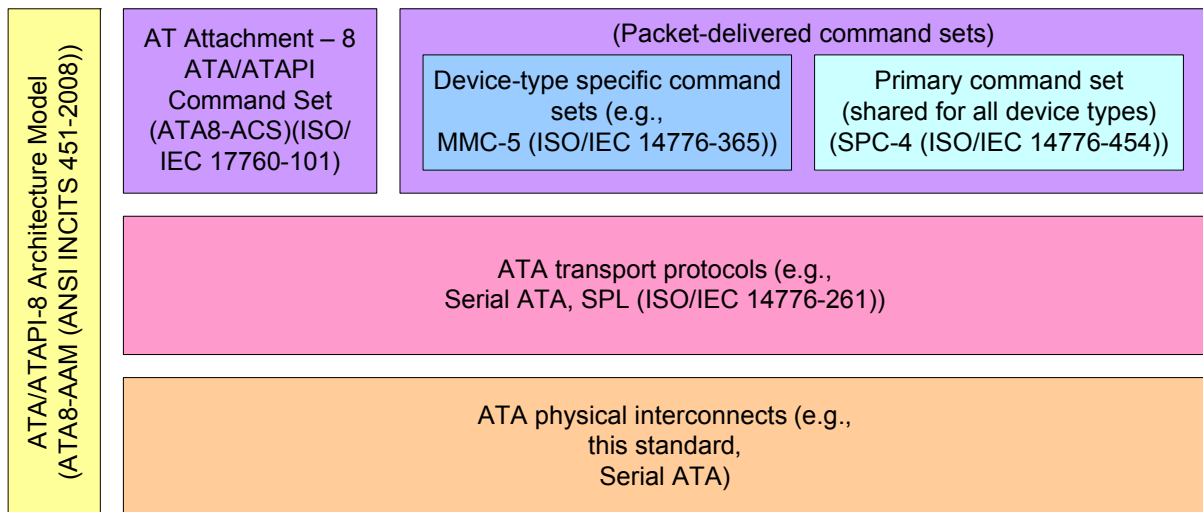

Figure 2 — ATA document relationships

Figure 1 and figure 2 show the general relationship of the documents to one another, and do not imply a relationship such as a hierarchy, protocol stack or system architecture.

These standards specify the interfaces, functions and operations necessary to ensure interoperability between conforming implementations. This standard is a functional description. Conforming implementations may employ any design technique that does not violate interoperability.

[ISO/IEC 14776-153:2015](https://standards.iteh.ai/catalog/standards/sist/7c53e8c5-515c-4a8b-b284-4b0401d2a5c3/iso-iec-14776-153-2015)
<https://standards.iteh.ai/catalog/standards/sist/7c53e8c5-515c-4a8b-b284-4b0401d2a5c3/iso-iec-14776-153-2015>