



# Standard Test Method for Inplane Shear Properties of Hoop Wound Polymer Matrix Composite Cylinders<sup>1</sup>

This standard is issued under the fixed designation D 5448/D 5448M; the number immediately following the designation indicates the year of original adoption or, in the case of revision, the year of last revision. A number in parentheses indicates the year of last reapproval. A superscript epsilon ( $\epsilon$ ) indicates an editorial change since the last revision or reapproval.

## 1. Scope

1.1 This test method determines the inplane shear properties of wound polymer matrix composites reinforced by high-modulus continuous fibers. It describes testing of hoop wound (90°) cylinders in torsion for determination of inplane shear properties.

1.2 The values stated in either SI units or inch-pound units are to be regarded separately as standard. Within the text the inch-pound units are shown in brackets. The values stated in each system are not exact equivalents; therefore, each system must be used independently of the other. Combining values from the two systems may result in nonconformance with the test method.

1.3 *This standard does not purport to address all of the safety problems, if any, associated with its use. It is the responsibility of the user of this standard to establish appropriate safety and health practices and determine the applicability of regulatory limitations prior to use.*

## 2. Referenced Documents

### 2.1 ASTM Standards:

- D 792 Test Methods for Density and Specific Gravity (Relative Density) of Plastics by Displacement<sup>2</sup>
- D 883 Terminology Relating to Plastics<sup>2</sup>
- D 2584 Test Method for Ignition Loss of Cured Reinforced Resins<sup>3</sup>
- D 2734 Test Method for Void Content of Reinforced Plastics<sup>3</sup>
- D 3171 Test Method for Fiber Content of Resin-Matrix Composites by Matrix Digestion<sup>4</sup>
- D 3878 Terminology Relating to High-Modulus Reinforcing Fibers and Their Composites<sup>4</sup>
- D 5229/D 5229M Test Method for Moisture Absorption Properties and Equilibrium Conditioning of Polymer Matrix Composite Materials<sup>4</sup>
- D 5449/D 5449M Test Method for Transverse Compressive

Properties of Hoop Wound Polymer Matrix Composite Cylinders<sup>4</sup>

D 5450/D 5450M Test Method for Transverse Tensile Properties of Hoop Wound Polymer Matrix Composite Cylinders<sup>4</sup>

E 4 Practices for Force Verification of Testing Machines<sup>5</sup>

E 6 Terminology Relating to Methods of Mechanical Testing<sup>5</sup>

E 111 Test Method for Young's Modulus, Tangent Modulus, and Chord Modulus<sup>5</sup>

E 122 Practice for Choice of Sample Size to Estimate the Average Quality of a Lot or Process<sup>6</sup>

E 177 Practice for Use of the Terms Precision and Bias in ASTM Test Methods<sup>6</sup>

E 251 Test Methods for Performance Characteristics of Metallic Bonded Resistance Strain Gages<sup>5</sup>

E 456 Terminology Relating to Quality and Statistics<sup>6</sup>

E 691 Practice for Conducting and Interlaboratory Study to Determine the Precision of a Test Method<sup>6</sup>

E 1237 Guide for Installing Bonded Resistance Strain Gages<sup>5</sup>

## 3. Terminology

3.1 **Definitions**—Terminology D 3878 defines terms relating to high-modulus fibers and their composites. Terminology D 883 defines terms relating to plastics. Terminology E 6 defines terms relating to mechanical testing. Terminology E 456 and Practice E 177 define terms relating to statistics. In the event of a conflict between terms, Terminology D 3878 shall have precedence over other standards.

3.2 **Description of Terms Specific to This Standard:**<sup>7</sup>

3.2.1 **hoop wound,  $n$** —a winding of a cylindrical component where the filaments are circumferentially oriented.

3.2.2 **inplane shear modulus,  $G_{12}$  [ $MT^{-1} T^{-2}$ ],  $n$** —the elastic shear modulus of a unidirectional material in the plane defined by axes parallel and perpendicular to the reinforcing fibers.

<sup>5</sup> Annual Book of ASTM Standards, Vol 03.01.

<sup>6</sup> Annual Book of ASTM Standards, Vol 14.02.

<sup>7</sup> If the term represents a physical quantity, its analytical dimensions are stated immediately following the term (or letter symbol) in fundamental dimension form, using the following ASTM standard symbology for fundamental dimensions, shown within square brackets: [ $M$ ] for mass, [ $L$ ] for length, [ $T$ ] for time, [ $\theta$ ] for thermodynamic temperature, and [ $nd$ ] for nondimensional quantities. Use of these symbols is restricted to analytical dimensions when used with square brackets, as the symbols may have other definitions when used without the brackets.

<sup>1</sup> This test method is under the jurisdiction of ASTM Committee D-30 on High Modulus Fibers and Their Composites and is the direct responsibility of Subcommittee D30.04 on Lamina and Laminate Test Methods.

Current edition approved Aug. 15, 1993. Published October 1993.

<sup>2</sup> Annual Book of ASTM Standards, Vol 08.01.

<sup>3</sup> Annual Book of ASTM Standards, Vol 08.02.

<sup>4</sup> Annual Book of ASTM Standards, Vol 15.03.

3.2.3 *inplane shear strain at failure*,  $\gamma_{12}^u$  [nd],  $n$ —the value of inplane shear strain at failure when an inplane shear load is applied to the material.

3.2.4 *inplane shear strength*,  $\tau_{12}$ , [ $MT^{-2} L^{-1}$ ],  $n$ —the strength of a unidirectional material when an inplane shear load is applied to the material.

3.2.5 *specimen*—a single part cut from a winding that meets the specifications of Fig. 1. Each winding may yield several specimens.

3.2.6 *winding*—an entire part completed by one winding operation and then cured.

#### 4. Summary of Test Method

4.1 A thin walled hoop wound cylinder nominally 100 mm [4 in.] in diameter and 140 mm [5½ in.] in length is bonded into two end fixtures. The specimen/fixture assembly is mounted in the testing machine and monotonically loaded in inplane shear while recording load. The inplane shear strength can be determined from the maximum load carried prior to failure. If the cylinder strain is monitored with strain gages then the stress-strain response, the inplane shear strain at failure, and the inplane shear modulus can be derived.

#### 5. Significance and Use

5.1 This test method is designed to produce inplane shear property data for material specifications, research and development, quality assurance, and structural design and analysis. Factors that influence the inplane shear response and should therefore be reported are material, method of material preparation, specimen preparation, specimen conditioning, environment of testing, specimen alignment and gripping, speed of testing, void content, and fiber volume fraction. Properties, in the test direction, that may be obtained from this test method are as follows:

5.1.1 *Inplane Shear Strength*,  $\tau_{12}^u$ ,

5.1.2 *Inplane Shear Strain at Failure*,  $\gamma_{12}^u$ , and

5.1.3 *Inplane Shear Modulus*,  $G_{12}$ .

#### 6. Interferences

6.1 *Material and Specimen Preparation*—Poor material fabrication practices, lack of control of fiber alignment, and

damage induced by improper coupon machining are known causes of high material data scatter in composites.

6.2 *Bonding Specimens to Test Fixtures*—A high percentage of failures in or near the bond between the test specimen and the test fixture, especially when combined with high material data scatter, is an indicator of specimen bonding problems. Specimen-to-fixture bonding is discussed in 11.5.

6.3 *System Alignment*—Excessive bending or axial loading will cause premature failure, as well as highly inaccurate shear modulus determination. Every effort should be made to eliminate excess bending and axial loading from the test system. Bending and axial loading may occur due to misaligned grips, misaligned specimens in the test fixtures, or from departures of the specimens from tolerance requirements. The alignment should always be checked as discussed in 12.2.

#### 7. Apparatus

7.1 *Micrometers*, suitable ball type for reading to within  $0.025 \pm 0.010$  mm [ $0.001 \pm 0.0004$  in.] of the specimen inner and outer diameters. Flat anvil type or micrometer calipers of similar resolution may be used for the overall specimen length and the gage length (the free length between the fixtures).

7.2 *Inplane Shear Fixture*—The inplane shear fixture consists of a steel outer shell, insert, and adaptor. An assembly drawing for these components and the test fixture is shown in Fig. 1.

7.2.1 *Outer Shell*—The outer shell (SI units, see Fig. 2; inch-pound units, see Fig. 3) is circular with a concentric circular hollow in one face, a groove along the diameter of the other face, and a center hole through the thickness. Along the diameter perpendicular to the groove, three pairs of small eccentric holes are placed at three radial distances. The two outer pairs of holes are threaded. Four additional threaded holes are placed at the same radial distance as the innermost pair of holes at 90° intervals starting 45° from the diameter that passes through the center groove.

7.2.2 *Insert*—The fixture insert is circular with a center hole through the thickness (SI units, see Fig. 4; inch-pound units, see Fig. 5). Two sets of holes are placed along a concentric centerline. These holes align with the innermost set of holes in the outer shell. The set of 4 holes at 90° intervals are counterbored. The insert is fastened inside the hollow of the outer shell to form the concentric groove used to put the specimen in the fixture.

7.2.3 *Adaptor*—The adaptor is circular with a square central torque nut raising out of one face, a flange along a diameter on the other face, and a central hole (SI units, see Fig. 6; inch-pound units, see Fig. 7). Two bolt holes are placed equidistant from the adaptor center on a diameter perpendicular to the centerline of the flange. The adaptor is fastened to the outer shell. The flange of the adaptor fits into the groove of the outer shell. The complete inplane shear specimen/fixture assembly is seen in Fig. 1.

NOTE 1—The outer shell and insert for the compression fixture are the same outer shell and insert used for the fixtures in Test Methods D 5449/D 5449M and D 5450/D 5450M.

7.3 *Testing Machine*, comprised of the following:

7.3.1 *Fixed Member*—A fixed or essentially stationary

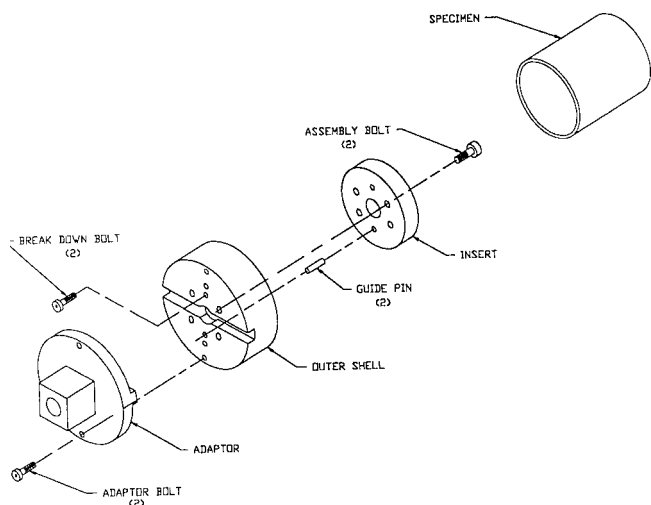

FIG. 1 Assembly Drawing for the Shear Fixture and Specimen

D 5448/D 5448M

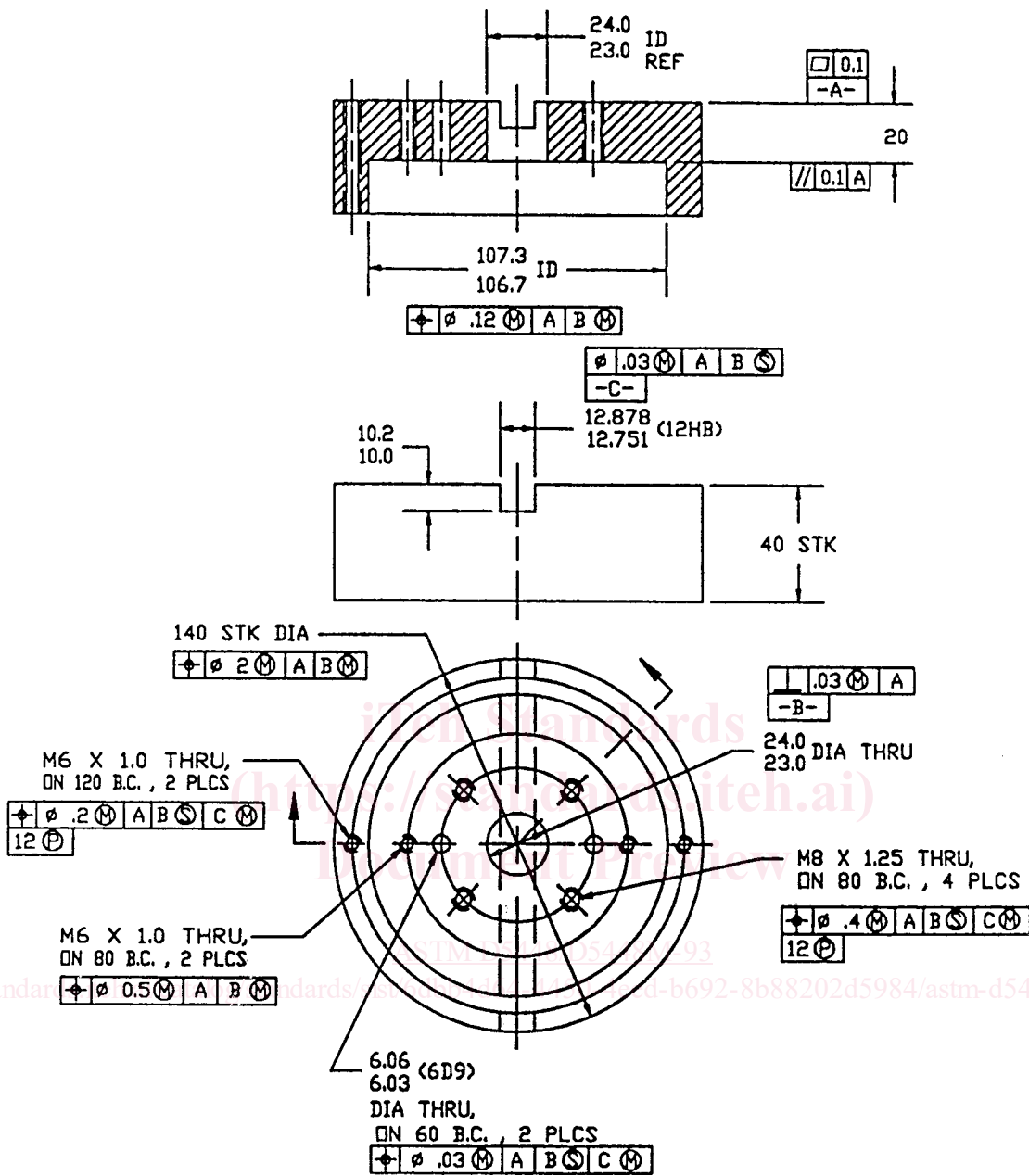

FIG. 2 Outer Shell of the Shear Fixture in SI Units

member, with respect to rotation, to which one end of the torsion specimen/fixture/adaptor assembly, shown in Fig. 3, can be attached.

7.3.2 *Rotational Member*—A rotational member to which the opposite end of the torsion specimen/fixture/adaptor assembly, shown in Fig. 1, can be attached. Either the rotational member or the fixed member shall be free to move axially to prevent the application of axial forces or the axial load shall be limited to 5 % of the axial strength of the material.

7.3.3 *Drive Mechanism*, for imparting to the movable member a uniform controlled angular velocity with respect to the fixed member. This angular velocity is to be regulated as specified in Section 9.

7.3.4 *Load Indicator*—A suitable load-indicating mechanism capable of showing the total torsional load carried by the

test specimen. This mechanism shall be essentially free of inertia-lag at the specified rate of testing and shall indicate the load within an accuracy of  $\pm 1\%$  of the actual value, or better.

7.3.5 *Construction Materials*—The fixed member, movable member, drive mechanism, fixtures, and adaptors shall be constructed of such materials and in such proportions that the total rotational deformation of the system contributed by these parts is minimized.

7.4 *Strain-Indicating Device*—Load versus strain data shall be determined by means of bonded resistance strain gages. Each strain gage shall be 6.3 mm [0.25 in.] in length. Strain gage rosettes ( $0^\circ/45^\circ/90^\circ$ ) shall be used to correct for gage misalignment. Gage calibration certification shall comply with Test Method E 251. Some guidelines on the use of strain gages on composites are presented in 7.4.1-7.4.4. A general reference

ASTM D 5448/D 5448M

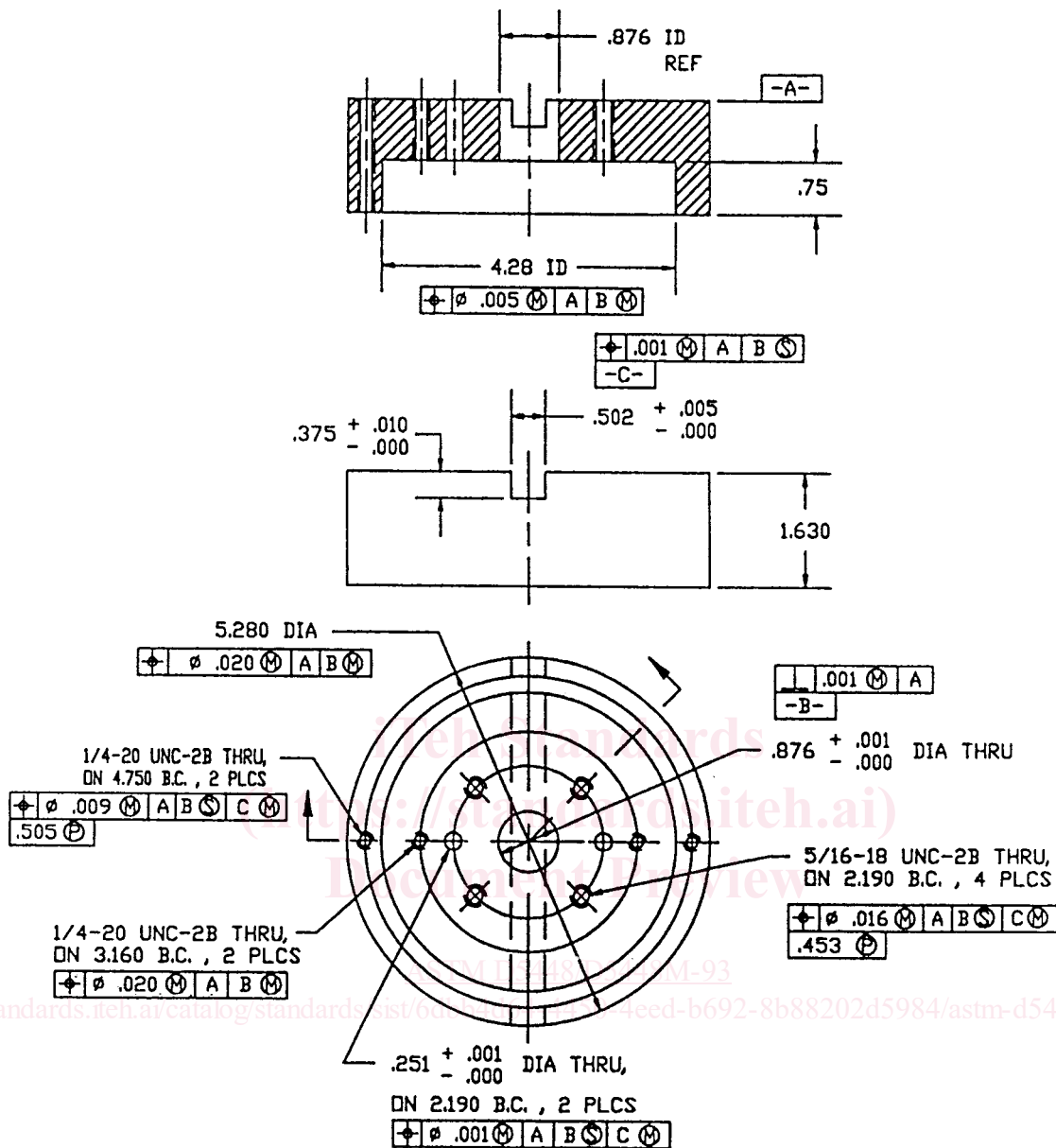

FIG. 3 Outer Shell for the Shear Fixture in Inch-Pound Units

on the subject is Tuttle and Brinson.<sup>8</sup>

7.4.1 *Surface Preparation*—The surface preparation of fiber-reinforced composites discussed in Guide E 1237 can penetrate the matrix material and cause damage to the reinforcing fibers, resulting in improper coupon failures. Reinforcing fibers should not be exposed or damaged during the surface preparation process. The strain gage manufacturer should be consulted regarding surface preparation guidelines and recommended bonding agents for composites, pending the development of a set of standard practices for strain gage installation surface preparation of fiber-reinforced composite materials.

7.4.2 *Gage Resistance*—Consideration should be given to the selection of gages having larger resistance to reduce

heating effects on low-conductivity materials. Resistances of 350Ω or higher are preferred. Additional considerations should be given to the use of the minimum possible gage excitation voltage consistent with the desired accuracy (1 to 2 V is recommended) to further reduce the power consumed by the gage. Heating of the coupon by the gage may affect the performance of the material directly, or it may affect the indicated strain due to a difference between the gage temperature compensation factor and the coefficient of thermal expansion of the coupon material.

7.4.3 *Temperature Considerations*—Consideration of some form of temperature compensation is recommended, even when testing at standard laboratory atmosphere. Temperature compensation is required when testing in nonambient temperature environments.

7.4.4 *Transverse Sensitivity*—Consideration should be given to the transverse sensitivity of the selected strain gage.

<sup>8</sup> Tuttle, M. E. and Brinson, H. F., "Resistance-Foil Strain-Gage Technology as Applied to Composite Materials," *Experimental Mechanics*, Vol 24, No. 1, March 1984, pp. 54-64; errata noted in Vol 26, No. 2, January 1986, pp. 153-154.

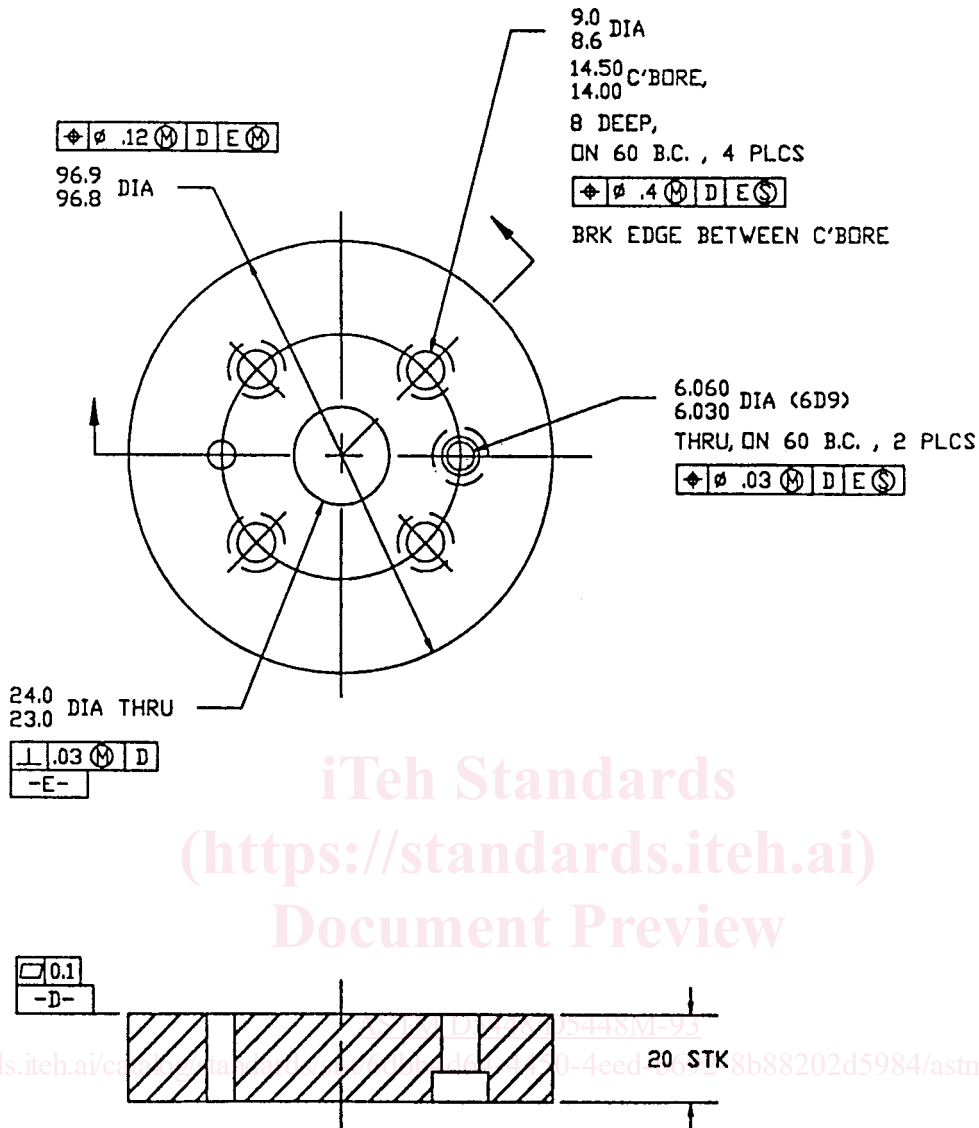

FIG. 4 Insert of the Shear Fixture in SI Units

The strain gage manufacturer should be consulted for recommendations on transverse sensitivity corrections and effects on composites.

**7.5 Conditioning Chamber**—When conditioning materials at nonlaboratory environments, a temperature/vapor-level controlled environment conditioning chamber is required which shall be capable of maintaining the required temperature to within  $\pm 3^\circ\text{C}$  [ $\pm 5^\circ\text{F}$ ] and the required relative vapor level to within  $\pm 3\%$ . Chamber conditions shall be monitored either on an automated continuous basis or on a manual basis at regular intervals.

**7.6 Environmental Test Chamber**—An environmental test chamber is required for testing environments other than ambient testing laboratory conditions. This chamber shall be capable of maintaining the gage section of the test specimen at the required test environment during the mechanical test.

## 8. Sampling and Test Specimens

**8.1 Sampling**—At least five specimens per test condition should be tested unless valid results can be gained through the

use of fewer specimens, such as in the case of a designed experiment. For statistically significant data, the procedures outlined in Practice E 122 should be consulted. The method of sampling shall be reported.

**8.2 Geometry**—The test specimen shall be as shown in Fig. 8. The length of all specimens shall be 140 mm [5.5 in.]. This will provide a 102 mm [4.0 in.] gage length. The inner diameter of all specimens shall be  $100 \pm 4$  mm [ $4.000 \pm 0.015$  in.]. Specimens may be fabricated on a tapered mandrel yielding a maximum taper over the specimen length of 0.0005 mm/mm on the diameter. The specimens shall have a nominal wall thickness of 2 mm [0.08 in.], the actual thickness to be specified by the winding parameters and shall be maintained as the test specimen is wound and cured.

**8.3 Winding**—All specimens shall be hoop wound (approximately  $90^\circ$ ) with a single tow and with enough layers to meet the thickness criterion described in 8.2.

## 9. Calibration

**9.1** The accuracy of all measurement equipment shall have



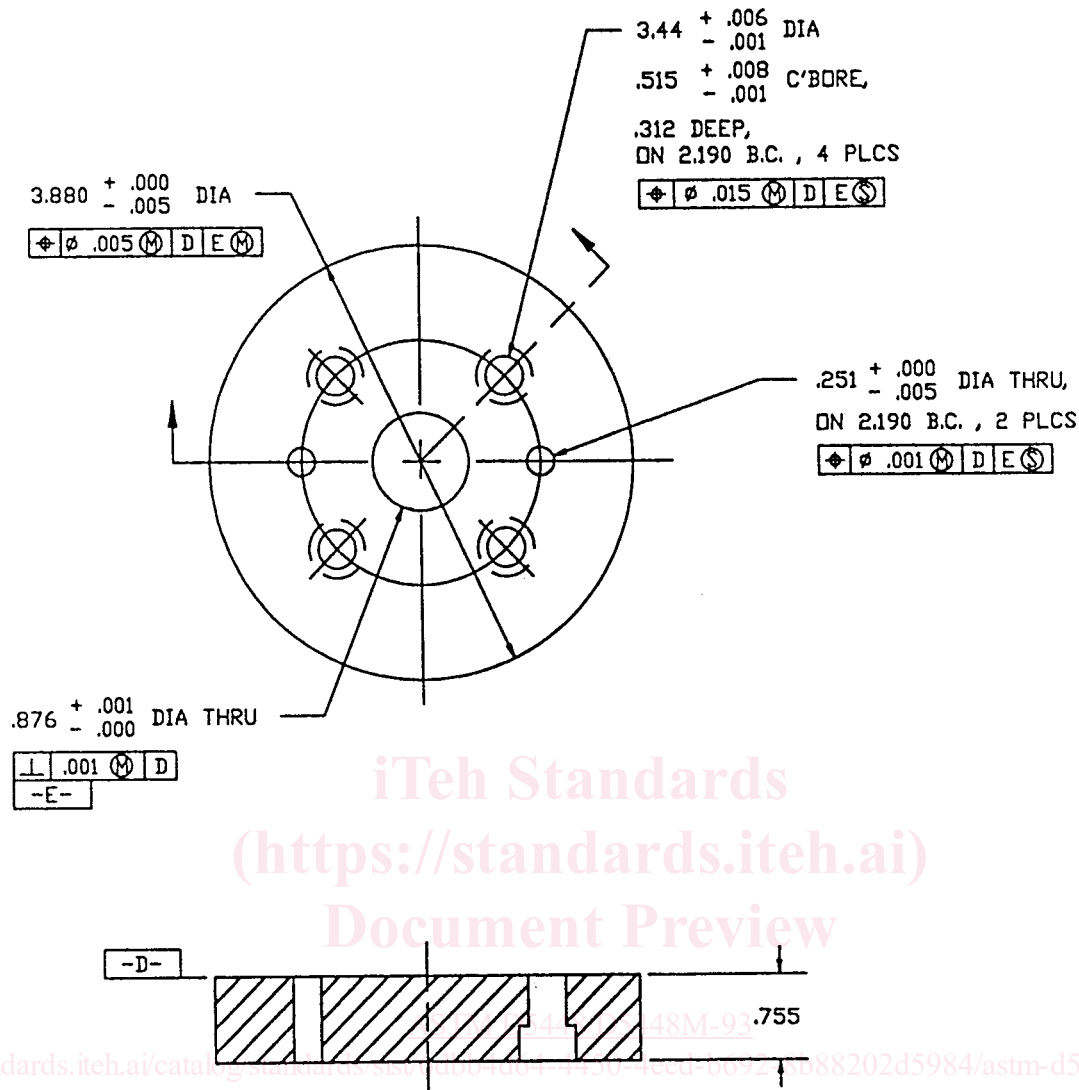

FIG. 5 Insert for the Shear Fixture in Inch-Pound Units

certified calibrations that are current at the time of use of the equipment.

## 10. Conditioning

10.1 *Standard Conditioning Procedure*—Unless a different environment is specified as part of the experiment, the test specimens shall be conditioned in accordance with Procedure C of Test Method D 5229 and stored and tested at standard laboratory atmosphere ( $23 \pm 2^\circ\text{C}$  [ $73.4 \pm 3.6^\circ\text{F}$ ] and at  $50 \pm 10\%$  relative humidity).

## 11. Procedure

11.1 *Parameters to be Specified Prior to Test:*

11.1.1 The sampling method, specimen geometry, and test parameters used to determine density and reinforcement volume.

11.1.2 The inplane shear specimen sampling method.

11.1.3 The environmental conditioning test parameters.

11.1.4 The inplane shear property and data reporting format desired.

NOTE 2—Specific material property, accuracy, and data reporting re-

quirements should be determined prior to test for proper selection of instrumentation and data recording equipment. Estimates of operating stress and strain levels should also be made to aid in transducer selection, calibration of equipment, and determination of equipment settings.

## 11.2 General Instructions:

11.2.1 Any deviation from this test method shall be reported.

11.2.2 Unless otherwise directed, determine specific gravity and reinforcement and void volume percentages for each winding. The material used for the determination of these properties should be extracted from the center of the winding if multiple specimens are extracted from one winding or from one of the ends of the winding if only one specimen is extracted from the winding. Determine and report specific gravity and density in accordance with Test Methods D 792. Determine and report volume percent of the constituents by one of the matrix digestion procedures of Test Method D 3171, or, for certain reinforcement materials such as glass and ceramics, by the matrix burn-off technique of Test Method D 2584. The void content equations of Test Methods D 2734