



Designation: F 2111 – 01

Standard Practice for Measuring Intergranular Attack or End Grain Pitting on Metals Caused by Aircraft Chemical Processes¹

This standard is issued under the fixed designation F 2111; the number immediately following the designation indicates the year of original adoption or, in the case of revision, the year of last revision. A number in parentheses indicates the year of last reappraisal. A superscript epsilon (ϵ) indicates an editorial change since the last revision or reappraisal.

1. Scope

1.1 This practice covers the procedures for testing and measuring intergranular attack (IGA) and end grain pitting on aircraft metals and alloys caused by maintenance or production chemicals.

1.2 The standard does not purport to address all qualification testing parameters, methods, critical testing, or criteria for aircraft production or maintenance chemical qualifications. Specific requirements and acceptance testing along with associated acceptance criteria may be found where applicable in procurement specifications, materials specifications, or appropriate process specifications.

1.3 *This standard does not purport to address all of the safety concerns, if any, associated with its use. It is the responsibility of the user of this standard to establish appropriate safety and health practices and determine the applicability of regulatory limitations prior to use.*

2. Referenced Documents

2.1 ASTM Standards:

E 3 Practice for Preparation of Metallographic Specimens²

G 1 Practice for Preparing, Cleaning, and Evaluating Corrosion Test Specimens³

G 15 Terminology Relating to Corrosion and Corrosion Testing³

G 46 Guide for Examination and Evaluation of Pitting Corrosion³

2.2 ASME Standard:

B46.1 Surface Texture (Surface Roughness, Waviness, and Lay)⁴

3. Terminology

3.1 Definitions of Terms Specific to This Standard:

3.1.1 *long transverse (LT)*—the longest dimension perpendicular to the rolling or extruded direction of the extrusion in the original shape.

3.1.2 *pit*—a depression or cavity with a width to depth ratio of <6 to 1.

3.1.3 *short transverse (ST)*—the shortest dimension perpendicular to the rolling or extruded direction of the extrusion in the original shape.

3.1.4 *surface roughness (R_a)*—filtered mean line $\mu\text{in.}$ (μm) as defined in ASME B46.1, Surface Texture.

4. Significance and Use

4.1 If not properly qualified, chemicals and chemical processes can attack metals used during aircraft maintenance and production. It is important to qualify only processes and chemical formulas that do not have any deleterious effects on aircraft metallic skins, fittings, components, and structures. This test procedure is used to detect and measure intergranular attack or pitting depth caused by aircraft maintenance chemical processes, hence, this test procedure is useful in selecting a process that will not cause intergranular attack or end grain pitting on aircraft alloys.

4.2 The purpose of this practice is to aid in the qualification or process conformance testing or production or maintenance chemicals for use on aircraft.

4.2.1 Some examples of maintenance and production chemicals include: organic solvents, paint strippers, cleaners, deoxidizers, water-based or semi-aqueous cleaners, or etching solutions and chemical milling solutions.

5. Apparatus and Materials

5.1 *Metallurgical Microscope*, capable of 500 \times or greater magnification with scaled filar units in microscope eyepiece.

5.2 *Metallurgical Polishing Wheel*, capable of polishing test specimen to a surface finish of 5- $\mu\text{in.}$ R_a or finer.

5.3 *Noncorrosive Metallurgical Quality Polishing Media or Compound*, capable of polishing test specimens to 5- $\mu\text{in.}$ R_a or finer.

6. Test Specimens

6.1 Unless otherwise specified, manufacture test specimens as follows:

6.1.1 Prepare at least one test specimen (or more when specified by applicable process specification) from plate, sheet,

¹ This practice is under the jurisdiction of ASTM Committee F07 on Aerospace and Aircraft and is the direct responsibility of Subcommittee F07.07 on Qualification Testing of Aircraft Cleaning Materials.

Current edition approved May 10, 2001. Published July 2001.

² *Annual Book of ASTM Standards*, Vol 03.01.

³ *Annual Book of ASTM Standards*, Vol 03.02.

⁴ Available from American Society of Mechanical Engineers, Headquarters, Three Park Ave., New York, NY 10016-5990.

extrusion, or hand forging as illustrated in Fig. 1.

6.1.2 Cut out metallurgical test specimen and polish Face A to 0.812 μm (32 $\mu\text{in.}$) or preferably finer with polish as given in 5.3.

7. Procedure

7.1 Expose entire polished specimen through normal production or maintenance cycle. Use test temperatures and periods of time representative of the highest usage temperature and longest exposure times associated with the chemical process. For conformance testing, process specimens with representative-like alloy parts through all operations including precleaning, post rinsing, and so forth, for the time necessary to remove the amount of metal specified by process or to achieve process specified cleanliness.

7.2 For chemicals normally used at room temperature for periods of less than 8 h, use 40.6°C (105°F) \pm 1°C (1.8°F) for an exposure time of 24 h.

7.3 If required, clean specimen by removing corrosion products in accordance with Practice G 1. An ideal procedure should remove only corrosion products and not result in the removal of any base metal.

7.4 After exposing the test specimens to the required times and temperatures, clean and mount metallurgical test specimen as illustrated in Fig. 2 in accordance with Practice E 3.

7.5 After mounting, metallurgical polish to a surface roughness of 0.127- μm (5- $\mu\text{in.}$) R_a or finer.

7.6 Metallurgical Evaluation of Polished Test Specimens:

7.6.1 Unless otherwise specified, observe test specimen under 100 to 500 \times magnification for end grain pitting and intergranular attack.

7.6.1.1 Measure maximum width and depth of pit as illustrated in Fig. 3.

7.6.1.2 Measure maximum length of intergranular attack starting from the surface of the metal into the bulk material in

the grain direction as illustrated in Fig. 3.

7.6.1.3 Guide G 46 may be used as an alternate method to evaluate pitting only.

7.6.2 See Terminology G 15 for definitions of terminology relating to corrosion and corrosion testing as a guidance document.

8. Report

8.1 Report the following information:

8.1.1 Contents of test report,

8.1.1.1 Description of chemical tested,

Examples: part number, formula, MSDS, or other manufacturer's identification number, and so forth,

8.1.2 Manufacturer of chemical,

8.1.3 Batch number or lot number,

8.1.4 Date of manufacture,

8.1.5 Dilution ratio (if applicable),

8.1.6 Test alloy and material specification (metallurgical heat number is optional),

8.1.7 Exposure method,

Examples: immersion, dip and hang, brush, spray, or other,

8.1.8 Exposure temperature $^{\circ}\text{C}$ to ($^{\circ}\text{F}$),

8.1.9 Exposure period (seconds, minutes, hours, or days),

8.1.10 Measured depth of maximum pit and magnification,

8.1.11 Measured width of maximum pit and magnification,

8.1.12 Measured length of maximum intergranular corrosion and magnification,

8.1.13 Signature of test engineer and date,

8.1.14 Approval signature of laboratory supervisor or manager and date,

8.1.15 Date tested,

8.1.16 Qualification document for conformance testing (if applicable),

Examples: material specifications, process specifications, procurement specifications.

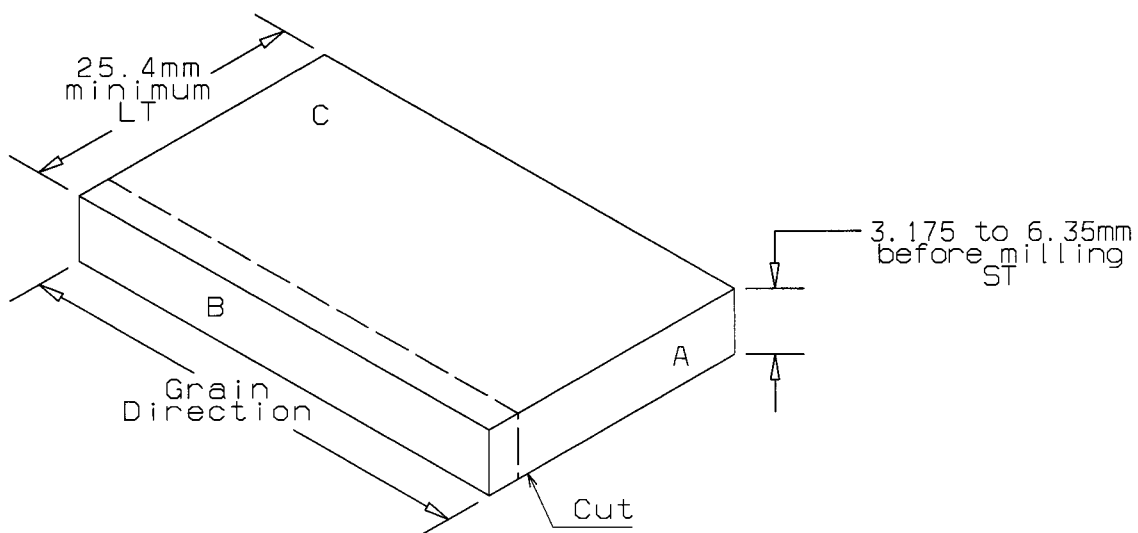

Face A is polished to .812 μm R_a or finer

FIG. 1 Face A