



Standard Test Method for Transverse Tensile Properties of Hoop Wound Polymer Matrix Composite Cylinders¹

This standard is issued under the fixed designation D 5450/D 5450M; the number immediately following the designation indicates the year of original adoption or, in the case of revision, the year of last revision. A number in parentheses indicates the year of last reapproval. A superscript epsilon (ϵ) indicates an editorial change since the last revision or reapproval.

1. Scope

1.1 This test method determines the transverse tensile properties of wound polymer matrix composites reinforced by high-modulus continuous fibers. It describes testing of hoop wound (90°) cylinders in axial tension for determination of transverse tensile properties.

1.2 The values stated in either SI units or inch-pound units are to be regarded separately as standard. Within the text, the inch-pound units are shown in brackets. The values stated in each system are not exact equivalents; therefore, each system must be used independently of the other. Combining values from the two systems may result in nonconformance with the standard.

1.3 *This standard does not purport to address all of the safety concerns, if any, associated with its use. It is the responsibility of the user of this standard to establish appropriate safety and health practices and determine the applicability of regulatory limitations prior to use.*

2. Referenced Documents

2.1 ASTM Standards:

- D 792 Test Methods for Density and Specific Gravity (Relative Density) of Plastics by Displacement²
- D 883 Terminology Relating to Plastics²
- D 2584 Test Method for Ignition Loss of Cured Reinforced Resins³
- D 2734 Test Method for Void Content of Reinforced Plastics³
- D 3171 Test Method for Fiber Content of Resin-Matrix Composites by Matrix Digestion⁴
- D 3878 Terminology of High-Modulus Reinforcing Fibers and Their Composites⁴
- D 5229/D 5229M Test Methods for Moisture Absorption Properties and Equilibrium Conditioning of Polymer Matrix Composite Materials⁴
- D 5448/D 5448M Test Method for Inplane Shear Properties of Hoop Wound Polymer Matrix Composite Cylinders⁴

¹ This test method is under the jurisdiction of ASTM Committee D-30 on High Modulus Fibers and Their Composites and is the direct responsibility of Subcommittee D30.04 on Lamina and Laminate Test Methods.

Current edition approved Aug. 15, 1993. Published October 1993.

² *Annual Book of ASTM Standards*, Vol 08.01.

³ *Annual Book of ASTM Standards*, Vol 08.02.

⁴ *Annual Book of ASTM Standards*, Vol 15.03.

D 5449/D 5449M Test Method for Transverse Compressive Properties of Hoop Wound Polymer Matrix Composite Cylinders⁴

E 4 Practices for Force Verification of Testing Machines⁵

E 6 Terminology Relating to Methods of Mechanical Testing⁵

E 111 Test Method for Young's Modulus, Tangent Modulus, and Chord Modulus⁵

E 122 Practice for Choice of Sample Size to Estimate a Measure of Quality for a Lot or Process⁶

E 132 Test Method for Poisson's Ratio at Room Temperature⁵

E 177 Practice for Use of the Terms Precision and Bias in ASTM Test Methods⁶

E 251 Test Methods for Performance Characteristics of Metallic Bonded Resistance Strain Gages⁵

E 456 Terminology Relating to Quality and Statistics⁶

E 691 Practice for Conducting an Interlaboratory Study to Determine the Precision of a Test Method⁶

E 1012 Practice for Verification of Specimen Alignment Under Tensile Loading⁵

E 1237 Guide for Installing Bonded Resistance Strain Gages⁵

3. Terminology

3.1 Definitions—Terminology D 3878 defines terms relating to high-modulus fibers and their composites. Terminology D 883 defines terms relating to plastics. Terminology E 6 defines terms relating to mechanical testing. Terminology E 456 and Practice E 177 define terms relating to statistics. In the event of a conflict between terms, Terminology D 3878 shall have precedence over other standards.

3.2 Descriptions of Terms:⁷

3.2.1 *hoop wound, n*—a winding of a cylindrical component where the filaments are circumferentially oriented.

3.2.2 *specimen, n*—a single part cut from a winding. Each

⁵ *Annual Book of ASTM Standards*, Vol 03.01.

⁶ *Annual Book of ASTM Standards*, Vol 14.02.

⁷ If the term represents a physical quantity, its analytical dimensions are stated immediately following the term (or letter symbol) in fundamental dimension form, using the following ASTM standard symbology for fundamental dimensions, shown within square brackets: [M] for mass, [L] for length, [T] for time, [θ] for thermodynamic temperature, and [nd] for non-dimensional quantities. Use of these symbols is restricted to analytical dimensions when used with square brackets, as the symbols may have other definitions when used without the brackets.

winding may yield several specimens.

3.2.3 *transverse tensile elastic modulus*, E_{22} [$MT^{-2}L^{-1}$], n —the tensile elastic modulus of a unidirectional material in the direction perpendicular to the reinforcing fibers.

3.2.4 *transverse tensile strain at failure*, ϵ_{22}^u [nd], n —the value of strain, perpendicular to the reinforcing fibers in a unidirectional material, at failure when a tensile load is applied in the direction perpendicular to the reinforcing fibers.

3.2.5 *transverse tensile strength*, σ_{22}^u [$MT^{-2}L^{-1}$], n —the strength of a unidirectional material when a tensile load is applied in the direction perpendicular to the reinforcing fibers.

3.2.6 *winding*, n —an entire part completed by one winding operation and then cured.

4. Summary of Test Method

4.1 A thin walled hoop wound cylinder nominally 100 mm [4 in.] in diameter and 140 mm [5.5 in.] in length is bonded into two end fixtures. The specimen/fixture assembly is mounted in the testing machine and monotonically loaded in tension while recording load. The transverse tensile strength can be determined from the maximum load carried prior to failure. If the cylinder strain is monitored with strain gages, then the stress-strain response of the material can be determined. From the stress-strain response the transverse tensile strain at failure, transverse tensile modulus of elasticity, and Poisson's ratio can be derived.

5. Significance and Use

5.1 This test method is used to produce transverse tensile property data for material specifications, research and development, quality assurance, and structural design and analysis. Factors which influence the transverse tensile response and should, therefore, be reported are: material, methods of material preparation, specimen preparation, specimen conditioning, environment of testing, specimen alignment and gripping, speed of testing, void content, and fiber volume fraction. Properties, in the test direction, which may be obtained from this test method include:

- 5.1.1 *Transverse Tensile Strength*, σ_{22}^u ,
- 5.1.2 *Transverse Tensile Strain at Failure*, ϵ_{22}^u ,
- 5.1.3 *Transverse Tensile Modulus of Elasticity*, E_{22} , and
- 5.1.4 *Poisson's Ratio*, ν_{21} .

6. Interference

6.1 *Material and Specimen Preparation*—Poor material fabrication practices, lack of control of fiber alignment, and damage induced by improper coupon machining are known causes of high material data scatter in composites.

6.2 *Bonding Specimens to Test Fixtures*—A high percentage of failures in or near the bond between the test specimen and the test fixtures, especially when combined with high material data scatter, is an indicator of specimen bonding problems. Specimen to fixture bonding is discussed in 11.5.

6.3 *System Alignment*—Excessive bending may cause premature failure, as well as highly inaccurate modulus of elasticity determination. Every effort should be made to eliminate excess bending from the test system. Bending may occur due to misaligned grips, misaligned specimens in the test fixtures, or from departures of the specimen from tolerance

requirements. The alignment should always be checked as discussed in 12.2.

7. Apparatus

7.1 *Micrometers*, suitable ball type for reading to within 0.025 ± 0.010 mm [0.001 ± 0.0004 in.] of the specimen inner and outer diameters. Flat anvil type micrometer or calipers of similar resolution may be used for the overall specimen length and the gage length (the free length between the fixtures).

7.2 *Tension Fixture*—The tension fixture consists of a steel outer shell, insert, load rod, and spherical washer. An assembly drawing for these components and the test fixture is seen in Fig. 1.

7.2.1 *Outer Shell*—The outer shell (metric units Fig. 2, english units Fig. 3) is circular with a concentric circular hollow in one face, a groove along the diameter of the other face, and a center hole through the thickness. Along the diameter perpendicular to the groove, three pairs of small eccentric holes are placed at three radial distances. The two outer pairs of holes are threaded. Four additional threaded holes are placed at the same radial distance as the innermost pair of holes, at ninety degree intervals starting forty-five degrees from the diameter that passes through the center groove.

7.2.2 *Insert*—The fixture insert is circular with a center hole through the thickness (metric units Fig. 4, english units Fig. 5). Two sets of holes are placed along a concentric centerline. These holes align with the innermost set of holes in the outer shell. The set of four holes at ninety degree intervals are counterbored. The insert is fastened inside the hollow of the outer shell to form the concentric groove used to put the specimen in the fixture (Fig. 1).

7.2.3 *Load Rod and Spherical Washers*—Two spherical washers for self alignment are placed over a 0.750-UNC-2A \times 6.0 inch load rod. The load rod is then slid through the center hole of the outer shell and insert assembly as illustrated in Fig. 1.

7.2.4 The outer shell and insert for the tension fixture are the same outer shell and insert used for the fixtures in Test Methods D 5448/D 5448M and D 5449/D 5449M.

7.3 *Testing Machine*, comprised of the following:
 7.3.1 *Fixed Member*—A fixed or essentially stationary member to which one end of the tension specimen/fixture

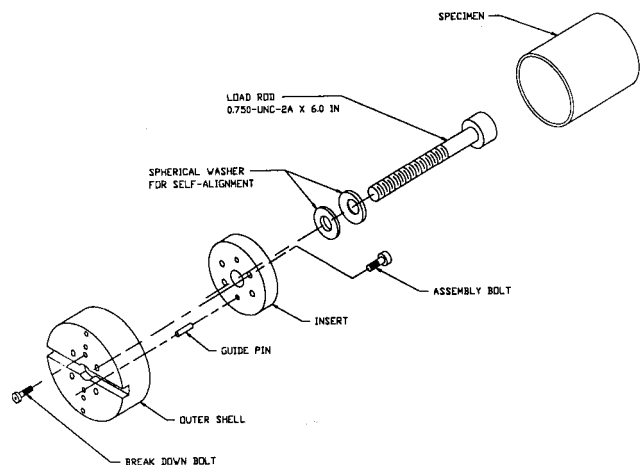

FIG. 1 Assembly Drawing for Tension Fixture and Specimen

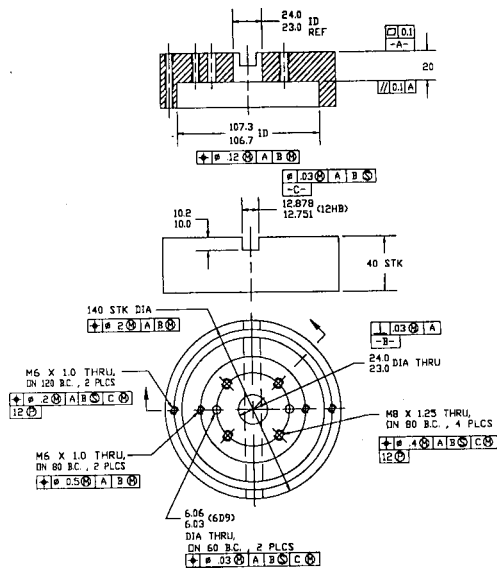

FIG. 2 The Outer Shell of the Tension Fixture in Metric Units

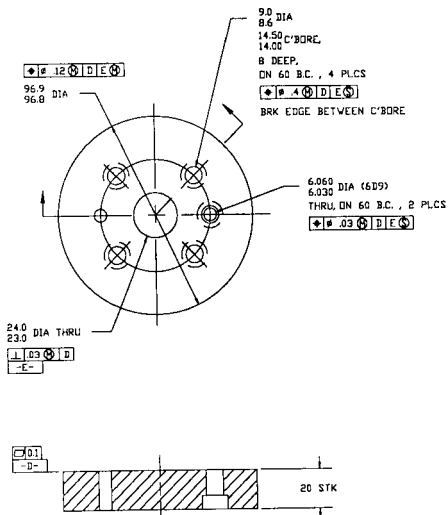

FIG. 4 The Insert of the Tensile Fixture in Metric Units

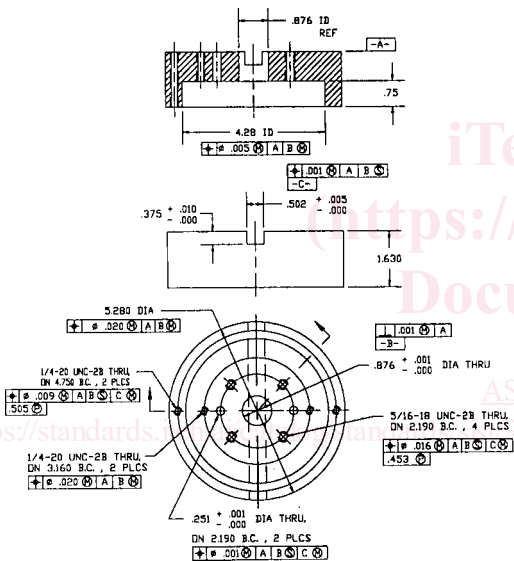

FIG. 3 The Outer Shell of the Tension Fixture in English Units

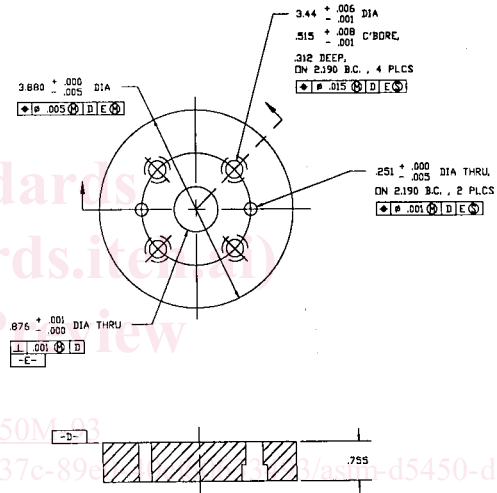

FIG. 5 The Insert of the Tensile Fixture in English Units

assembly, shown in Fig. 1, can be attached.

7.3.2 *Movable Member*—A movable member to which the opposite end of the tension specimen/fixture assembly, shown in Fig. 1, can be attached.

7.3.3 *Drive Mechanism*, for imparting to the movable member a uniform controlled velocity with respect to the fixed member, this velocity to be regulated as specified in 11.6.

7.3.4 *Load Indicator*—A suitable load-indicating mechanism capable of showing the total tensile load carried by the test specimen. This mechanism shall be essentially free of inertia-lag at the specified rate of testing and shall indicate the load within an accuracy of $\pm 1\%$ of the actual value, or better. The accuracy of the testing machine shall be verified in accordance with Practice E 4.

7.3.5 *Construction Materials*—The fixed member, movable member, drive mechanism, and fixtures shall be constructed of such materials and in such proportions that the total longitudi-

dinal deformation of the system contributed by these parts is minimized.

7.4 *Strain-Indicating Device*—Load versus strain data shall be determined by means of bonded resistance strain gages. Each strain gage shall be 6.3 mm [0.25 in.] in length. The specimen shall be instrumented to measure strain in both the axial and circumferential directions to determine Poisson's ratio. Strain gage rosettes ($0^\circ/45^\circ/90^\circ$) shall be used to correct for gage misalignment. Gage calibration certification shall comply with Test Method E 251. Some guidelines on the use of strain gages on composites are as follows. A general reference on the subject is Tuttle and Brinson.⁸

7.4.1 *Surface Preparation*—The surface preparation of fiber-reinforced composites, discussed in Practice E 1237, can penetrate the matrix material and cause damage to the reinforcing fibers, resulting in improper coupon failures. Reinforcing fibers should not be exposed or damaged during the surface

⁸ Tuttle, M. E., and Brinson, H. F., "Resistance-Foil Strain-Gage Technology as Applied to Composite Materials," *Experimental Mechanics*, Vol 24, No. 1, March 1984; pp. 54-64; errata noted in Vol 26, No. 2, Jan. 1986, pp. 153-154.

preparation process. The strain gage manufacturer should be consulted regarding surface preparation guidelines and recommended bonding agents for composites, pending the development of a set of standard practices for strain gage installation surface preparation of fiber-reinforced composite materials.

7.4.2 Gage Resistance—Consideration should be given to the selection of gages having larger resistance to reduce heating effects on low-conductivity materials. Resistances of 350Ω or higher are preferred. Additional considerations should be given to the use of the minimum possible gage excitation voltage consistent with the desired accuracy (1 to 2 volts is recommended) to further reduce the power consumed by the gage. Heating of the coupon by the gage may affect the performance of the material directly, or it may affect the indicated strain due to a difference between the gage temperature compensation factor and the coefficient of thermal expansion of the coupon material.

7.4.3 Temperature Considerations—Consideration of some form of temperature compensation is recommended, even when testing at standard laboratory atmosphere. Temperature compensation is required when testing in nonambient temperature environments.

7.4.4 Transverse Sensitivity—Consideration should be given to the transverse sensitivity of the selected strain gage. The strain gage manufacturer should be consulted for recommendations on transverse sensitivity corrections and effects on composites. This is particularly important for a transversely mounted gage used to determine Poisson's ratio.

7.5 Conditioning Chamber—When conditioning materials at nonlaboratory environments, a temperature/vapor-level controlled environment conditioning chamber is required, which shall be capable of maintaining the required temperature to within ±3°C [±5°F] and the required relative vapor level to within ±3 %. Chamber conditions shall be monitored either on an automated continuous basis or on a manual basis at regular intervals.

7.6 Environmental Test Chamber—An environmental test chamber is required for test environment other than ambient testing laboratory conditions. This chamber shall be capable of maintaining the gage section of the test specimen at the required test environment during the mechanical test.

8. Sampling and Test Specimens

8.1 Sampling—At least five specimens per test condition should be tested unless valid results can be gained through the use of fewer specimens, such as in the case of a designed experiment. For statistically significant data, the procedures outlined in Practice E 122 should be consulted. The method of sampling shall be reported.

8.2 Geometry—The test specimen shall be as shown in Fig. 6. The length of all specimens shall be 140 mm [5.5 in.]. This provides a gage length of 102 mm [4.0 in.]. The inner diameter of all specimens shall be 102 ± 4 mm [4.000 ± 0.015 in.]. Specimens may be fabricated on a tapered mandrel yielding a maximum taper over the specimen length of 0.0005 mm/mm [in./in.] on the diameter. The specimens shall have a nominal wall thickness of 2 mm [0.08 in.], the actual thickness to be specified by the winding parameters and shall be maintained as the test specimen is wound and cured.

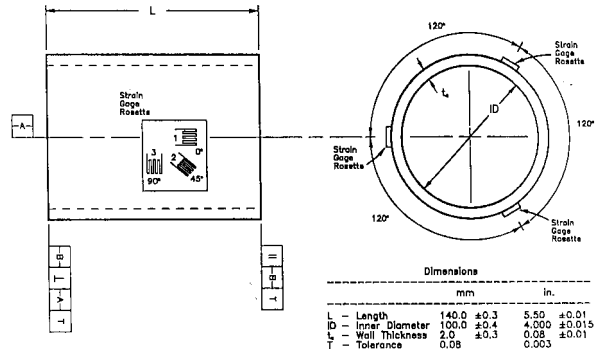

NOTE 1—Tube may be fabricated on a tapered mandrel with maximum taper of 0.0005 in./in. (0.0005 mm/mm) on the diameter.

NOTE 2—Actual measure of inner diameter will depend on specimen placement along tapered mandrel during fabrication.

FIG. 6 Test Specimen Shown with Strain Gage Configuration

8.3 Winding—All specimens shall be hoop wound (approximately 90°) with a single tow and enough layers to meet the thickness criterion previously described.

9. Calibration

9.1 The accuracy of all measuring equipment shall have certified calibrations that are current at the time the equipment is used.

10. Conditioning

10.1 *Standard Conditioning Procedure*—Unless a different environment is specified as part of the experiment, the test specimens shall be conditioned in accordance with Procedure C of Test Method D 5229/D 5229M and stored and tested at standard laboratory atmosphere (23 ± 2°C [73.4 ± 3.6°F] and at 50 ± 10 % relative humidity).

11. Procedure

11.1 *Parameters to be Specified Prior to Test:*

11.1.1 The sampling method, specimen geometry, and test parameters used to determine density and reinforcement volume,

11.1.2 The tension specimen sampling method,

11.1.3 The environmental conditioning test parameters, and

11.1.4 The tensile property and data reporting format desired.

NOTE 1—Specific material property, accuracy, and data reporting requirements should be determined prior to test for proper selection of instrumentation and data recording equipment. Estimates of operating stress and strain levels should also be made to aid in transducer selection, calibration of equipment, and determination of equipment settings.

11.2 *General Instructions:*

11.2.1 Any deviation from this test method shall be reported.

11.2.2 Unless otherwise directed, determine specific gravity and reinforcement and void volume percentages for each winding. Extract the material used for the determination of these properties from the center of the winding if multiple specimens are extracted from one winding or from one of the ends of the winding if only one specimen is extracted from the winding. Determine and report specific gravity and density as