



# Standard Test Method for Shock Sensitivity of Liquid Monopropellants by the Card-Gap Test<sup>1</sup>

This standard is issued under the fixed designation D 2539; the number immediately following the designation indicates the year of original adoption or, in the case of revision, the year of last revision. A number in parentheses indicates the year of last reapproval. A superscript epsilon ( $\epsilon$ ) indicates an editorial change since the last revision or reapproval.

## 1. Scope

1.1 In considering the handling properties of a liquid propellant, serious consideration is given to the possibility of hazard initiated by hydrodynamic shock. The consequences of such a shock may include: (1) nonpropagating explosion, (2) propagating but low-velocity detonation, and (3) propagating high-velocity detonation. All three are hazards; the test described herein is useful for one hazard only, namely propagating high-velocity detonation.

1.2 *This standard should be used to measure and describe the properties of materials, products, or assemblies in response to heat and flame under controlled laboratory conditions and should not be used to describe or appraise the fire hazard or fire risk of materials, products, or assemblies under actual fire conditions. However, results of this test may be used as elements of a fire risk assessment which takes into account all of the factors which are pertinent to an assessment of the fire hazard of a particular end use.*

1.3 *This standard does not purport to address all of the safety problems, if any, associated with its use. It is the responsibility of the user of this standard to establish appropriate safety and health practices and determine the applicability of regulatory limitations prior to use.*

1.4 The values stated in SI units are to be regarded as the standard. The values given in parentheses are for information only.

## 2. Summary of Test Method

2.1 This test method gives an evaluation of the sensitivity of a high-energy liquid propellant in terms of a stack of plastic cards inserted between a sample of liquid and a standard booster charge of high explosive. The sensitivity value is taken as the number of cards required to attenuate the booster shock just enough that the liquid detonates in 50 % of the trials. For an unknown liquid, 15 to 25 shots (requiring up to 1000 mL of

liquid) can be needed to define its sensitivity value. Because of the destructive nature of the test, a sufficient supply of expendable parts must be available before a sensitivity determination is attempted.

2.2 The card-gap test described is a measure of the hydrodynamic shock required to produce a stable, high-velocity detonation in a 1-in. standard steel pipe. Because of the large sample size subjected to this detonability test, the test is not to be done in the laboratory. The advantages of the card-gap test are its practical scale, reproducibility, and moderate material cost. The interpretation of results of the test is a matter of considerable judgment. While a propellant may show a low sensitivity in the card-gap test, this does not preclude the possibility of other dangers. On the other hand, a very high card-gap sensitivity does not always preclude the usability of such a liquid propellant, since it is possible that suitable engineering design can incorporate preventative measures against propagation of detonation. It is known that the degree of confinement, size, and material of the container, among other parameters, influence detonation propagation; therefore, the results of any specific test may be highly apparatus-dependent.

NOTE 1—Gap tests for determining explosive sensitivity are new. A technique of using paper cards for the gap materials and steep pipe for containers was developed in England at the Explosives Research and Development Establishment. The version described herein is essentially the Naval Ordnance Laboratory modification. The test is valuable because it yields reproducible data and it has been found that results of different investigators show close agreement.

## 3. Significance and Use

3.1 The property measured is the tendency of a propellant to undergo a high-order detonation when subjected to a given hydrodynamic shock. One limitation of the test is the difficulty of applying it to materials under conditions where the vapor pressure exceeds 1 atm.

3.2 The test is valuable because it yields very reproducible data, and it has been found that results of different investigators show close agreement.

## 4. Apparatus

4.1 *Cup*—The liquid under test is held in a cylindrical steel cup, closed at the bottom by a thin, flat diaphragm. It shall be fabricated as follows (Fig. 1):

<sup>1</sup> This test method is under the jurisdiction of ASTM Committee F-7 on Aerospace Industry Methods and is the direct responsibility of Subcommittee F07.02 on Propellant Technology.

Current edition approved March 15, 1993. Published May 1993. Originally published as D 2539 – 66 T. Last previous edition D 2539 – 70 (1980).

This test method is identical in substance with the Card Gap Test for Shock Sensitivity of Liquid Monopropellants recommended by the Interagency Chemical Rocket Propulsion Group, and published by the Chemical Propulsion Information Agency, Test No. 1, March 1960.

**TABLE 1 Typical Experimental Data From a Sensitivity Evaluation**

Shot No.	No. of Cards	Result <sup>A</sup>	Shot No.	No. of Cards	Result <sup>A</sup>
1	0	+	14	20	-
2	32	-	15	19	+
3	16	+	16	20	-
4	24	-	17	19	+
5	20	+	18	20	+
6	22	-	19	21	-
7	21	-	20	20	-
8	20	-	21	19	-
9	19	+	22	18	+
10	20	+	23	19	+
11	21	+	24	20	+
12	22	-	25	21	-
13	21	-			

<sup>A</sup> Key: + = liquid detonated.  
 - = liquid failed to detonate.

**TABLE 2 Data of Table 1, Arranged to Show 50 % Point**

No. of Cards	Result
0	+
16	+
18	+
19	++++-
20	++++----
21	-----+
22	--
24	-
32	-

from the furnace and cooled to room temperature, the tape is ready for use.

4.1.5 The diaphragm shall be fused to the PTFE coating on the pipe as follows: a piece of annealed tape shall be supported on a cushion of six layers of glass cloth stacked on a solid backing. The coated pipe shall be set on top of the tape, weighted with 60 lb (27 kg), and heated for 15 min at 380°C. The weight shall be kept in place during the 15-min cooling period. Excess tape shall be trimmed off.

4.1.6 The finished cup shall be tested for leaks before use.

4.1.7 Alternatively, the diaphragm can be formed from 0.002-in. (0.05-mm) polyethylene film secured by a rubber band or the cardboard spacer. The film shall be stretched taut and is perfectly acceptable as long as it does not leak or react with the liquid to be contained.

4.2 *Booster*—The booster charge shall consist of a cylindrical tetryl pellet (Note 2) nominally 1 in. (25.4 mm) high by 1<sup>5</sup>/<sub>8</sub> in. (41.3 mm) in diameter, weighing about 50 g. The density of these pellets should be 1.57 ± 0.03 g/cm<sup>3</sup> in accordance with Army ordnance Drawing 82-3-591C.

NOTE 2—Pentolite may *not* be substituted.

NOTE 3—**Warning:** Tetryl is a highly toxic material; those who handle it should exercise particular care to avoid spreading the dust by contact of the hands with other parts of the body. Frequent washing of the hands with soap and water is desirable. Working garments should be free from dust-collecting features such as trouser cuffs, and should be laundered frequently. Although not regarded as unusually sensitive, tetryl is a very powerful explosive and shall be handled with due respect. Rough or careless treatment of any sort shall be entirely avoided.

4.3 *Cards*<sup>2</sup>—The variable gap shall be built from circular cards, 1.55 in. (39.4 mm) in diameter, punched from cellulose acetate sheet nominally 0.010 in. (0.254 mm) thick. The sheet stock shall have smooth surfaces free from ripples, thick spots, and dimples, and should be dimensionally stable; thickness shall be held to close tolerances. Because of its thermoplastic nature, acetate sheet is not suitable as a gap material where sensitivity determinations are being carried out at temperatures much in excess of 100°C. In the event that such investigations are undertaken, it will be necessary to find a gap material dimensionally stable at high temperature.

4.4 *Target Plate*—Following a test shot, evidence is required to show whether or not the liquid has detonated. This evidence is provided by the condition of the target plate, a cold-rolled mild steep plate 4 by 4 by 3/8 in. (102 by 102 by 9.5 mm), which shall be placed in a horizontal position directly above the cup. It shall rest on a cardboard collar which fits tightly around the outside of the cup and supports the plate at a distance of 1/8 to 1/4 in. (3.2 to 6.4 mm) above the surface of the liquid. A gap is recommended to prevent chemical reaction between corrosive liquids and the target plate, and to prevent heat transfer between plate and liquid in tests above or below ambient temperature.

4.5 *Detonator Support Block*—The tetryl booster pellet shall rest on a cylindrical block, 1.57 in. (39.9 mm) in diameter and 1 in. (25 mm) high, aligned axially with the pellet. The block shall be made from cork or soft wood, with a 0.280-in.

4.1.1 Each end of a section of 1-in. Schedule 40 extruded black steel pipe shall be faced in a lathe to produce an overall length of 3.0 in. (76.2 mm).

4.1.2 The pipe shall be degreased in a solvent bath. The inside must be very smooth, clean, and free from pitting and rust to facilitate coating. Superficial rust can be removed by burnishing with a suitable wire brush.

4.1.3 The pipe shall be dipped into a bath of undiluted polytetrafluoroethylene (PTFE) black enamel and set upright on blotting paper for a draining period of at least 10 min. After drying in an oven at 90°C for 10 min, it shall be baked at 380°C for 15 min. The enamel coating produced in this manner provides sufficient protection from liquids as corrosive as 90 % nitric acid (HNO<sub>3</sub>) at room temperature. For further protection, the pipe can be given supplemental coats of PTFE aqueous dispersion. These shall be applied in exactly the same manner as that used for the original coat of black enamel. Each coat can be dried and fused before applying the next one.

4.1.4 The diaphragm shall be made from 0.003-in. (0.08-mm) PTFE tape. As received from the manufacturer, the tape is not suitable for use, since there are unrelieved stresses present which produce wrinkling in the finished diaphragm. To correct this condition, the material shall be annealed as follows: the tape shall be cut into 1<sup>3</sup>/<sub>4</sub>-in. (44.5-mm) lengths which are placed between two pieces of glass-cloth tape. One layer of these sandwiches shall be placed on a smooth sheet of stainless steel and covered with a flat piece of asbestos paper 1/16-in. (1.6 mm) thick. The entire assembly shall be baked in a furnace at 380°C for 30 to 40 min, after which time the oven shall be turned off and allowed to cool for 1 to 2 h. After it is removed

<sup>2</sup> Eastman Kodak Co.'s Kodapak IV has been found satisfactory for this purpose.

**TABLE 3 Abbreviated Procedure for Determination of 50 % Point for Various Materials With a Sharp Cutoff(After Detonation on First Test at Zero Gap)<sup>A</sup>**

Designation	Basic Test Pattern <sup>B</sup>		Supplementary Tests Required to Establish 50 % Point	Results of Supplementary Tests <sup>B</sup>		50 % Point
	Number of Cards			Number of Cards		
	N	N + 1		N - 1	N + 2	
I	++	--	none	...	...	N + 1/2
II	+-	-+	none	...	...	N + 1/2
III	+-	--	two tests at N - 1	--	...	N - 1
				++	...	N
				+-	...	N - 1/2
IV	++	-+	two tests at N + 2	...	--	N + 1
				...	++	N + 2
				...	-+	N + 1 1/2

<sup>A</sup> Key: N = an integer  
 + = detonation  
 - = no detonation  
 ... = no tests needed

<sup>B</sup> For a particular number of cards the order in which the results are obtained is immaterial.

**TABLE 4 Sample Determination of 50 % Point Using Abbreviated Procedure**

Step	No. of Cards	Symbol in Table 1	Result of Test
50 % Point = 10 Cards			
1	0	...	+
2	8	...	+
3	16	...	-
4	12	...	-
5	10	N	+
6	11	N + 1	- basic test configura-
7	10	N	- } tion
8	11	N + 1	-
9	9	N - 1	+supplementary test
10	9	N - 1	+
50 % Point = 11.5 Cards			
1	0	...	+
2	8	...	+
3	16	...	-
4	12	N + 2	-supplementary test
5	10	N	+
6	11	N + 1	- basic test configura-
7	10	N	+ tion
8	11	N + 1	+
9	12	N + 2	+supplementary test

(7.11-mm) hole along its cylindrical axis. This hole shall be of such diameter that the detonator will slide into it with a snug push-fit. The block itself shall rest on the shoulder formed at the junction of the pellet tube and support tube.

**4.6 Detonator**—Detonation in the booster pellet shall be initiated by an electric blasting cap which fits snugly into the hole drilled through the detonator support block, its tip just touching the center of the bottom face of the pellet. The cap used is known as the Engineer Corps Special, and is considerably more powerful than the No. 8 commercial cap.

**NOTE 4—Warning:** Blasting caps contain primary explosives, which are easily initiated by relatively mild physical shock. Consequently, every precaution shall be taken by those who work with them, with particular emphasis on gentle handling and protection from electrostatic charges. Accumulation of static charges by personnel should be prevented by use of all cotton clothing and special conductive shoes.

**4.7 Charge Support**—The various test components shall be properly aligned in a vertical train. One convenient method

consists of a series of nested cardboard support tubes on a steel firing pedestal, as shown in Fig. 2. Snugness of fit of the tubes is critical. A set known as a NOLGAP assembly consists of one support tube, one pellet tube, one coupling tube, and two collar tubes. The firing pedestal supports the entire test assembly at a convenient working height. Complete details of its construction are given in Fig. 3. An alternative charge assembly design developed by Army Ballistic Missile Agency is shown in Figs. 4 and 5.

**4.8 Firing Chamber**—It is necessary to provide protection from high-velocity shrapnel and some means of recovering the target. In some instances it is also desirable to reduce noise from the shot. One solution consists in using an all steel chamber in the shape of a simple maze (Fig. 6). Less elaborate structures have been developed at other laboratories and function satisfactorily.

**4.8.1** Another chamber is illustrated in Fig. 7. The reinforced concrete wall is employed to protect personnel who conduct the test from a distance of 200 ft (61 m). This type of enclosure is only acceptable where three sides of the test site are unoccupied for a distance of several hundred feet, since it is possible that some shrapnel may travel this distance. It is recommended that the side apron of the metal shield be lined with a layer of high-strength steel since this area sustains the most severe damage. Additional liners can be welded on at the site as needed. Fig. 8 illustrates another possible test shelter.

**4.9 Firing Equipment**—Before each shot, the firing circuit should be tested for continuity with a blasting galvanometer. The shot may conveniently be fired from the remote control point by means of a portable “blasting machine.” The firing line should consist of 16-gage or heavier duplex copper conductor cable.

**5. Hazards**

**5.1** Because of the fairly large quantities of explosives involved in propagation tests, they cannot be performed in the laboratory, but must be carried out at a suitable firing site. Before attempting to employ the test, those lacking experience should be thoroughly educated in the safe handling of explosives. Special safety precautions are recommended wherever hazards exist that are peculiar to the materials or procedures of the test. No attempt has been made to treat the general aspects

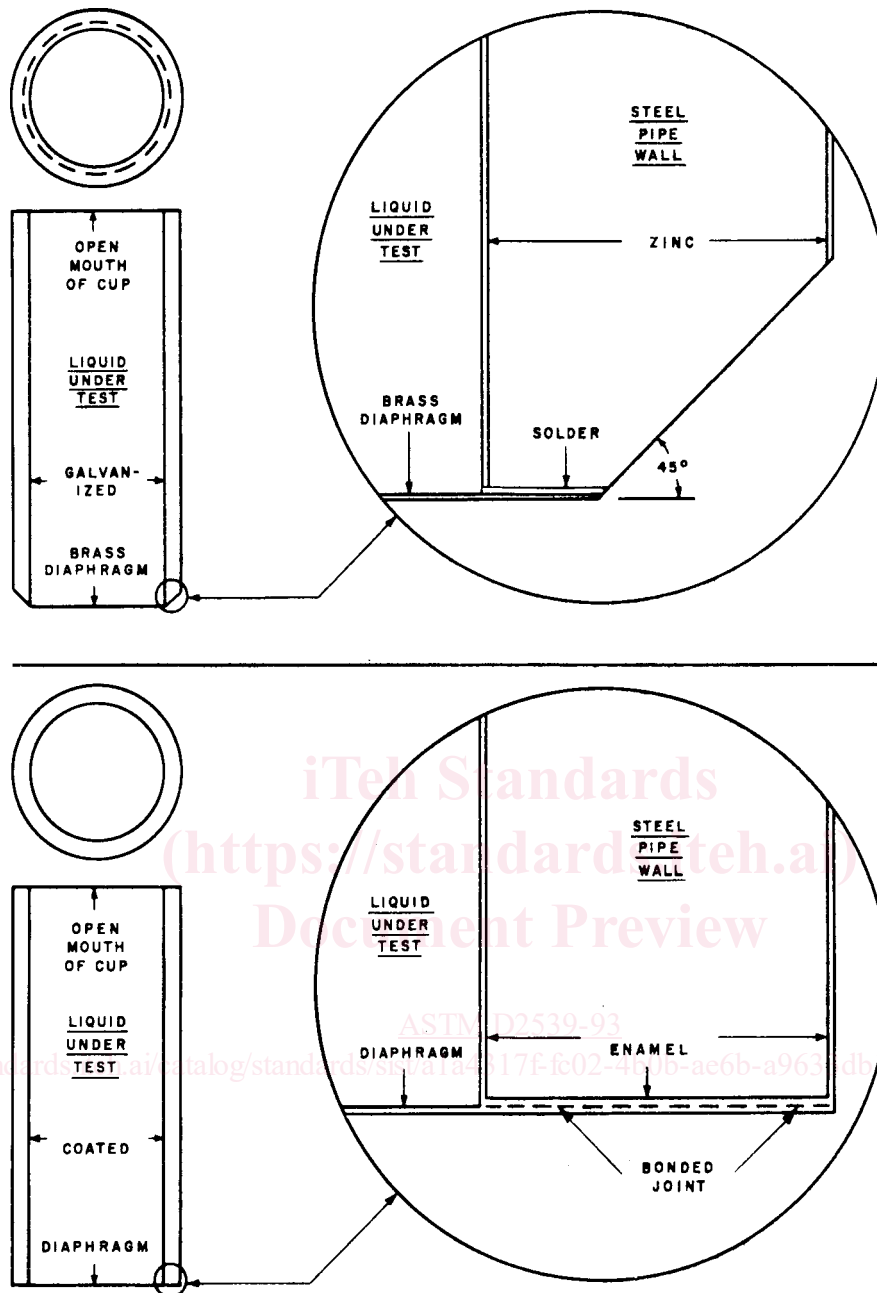

FIG. 1 Cup Construction

of safety in explosives handling, since the literature ((1-7))<sup>3</sup> amply cover this subject. State and local regulations concerning transportation, storage and use of explosives should be consulted and followed.

**6. Preparation of Apparatus**

6.1 The location of sensitivity value, of the 50 % point, for a given liquid follows a fixed pattern. Unless there is some idea of the sensitivity of the liquid beforehand, the first shot shall be

made at zero gap, that is, with no cards between booster and cup. Failure of the liquid to detonate under this condition of maximum shock means that the gap test is not capable of measuring its sensitivity. If detonation does occur, the next shot shall be made at an arbitrary value of 32 cards. If the liquid fails to detonate at this value, half as many cards shall be used for the next shot; if it detonates at 32 cards, twice as many shall be used for the third shot. This procedure shall be continued until, on the *n*th shot, a reversal in trend is observed, that is, a transition from detonation to failure, or vice versa. The number of cards for the next shot shall then be fixed halfway between the number used in shot *N* and that used in shot *N* - 1. This

<sup>3</sup> The boldface numbers in parentheses refer to the list of references at the end of this test method.

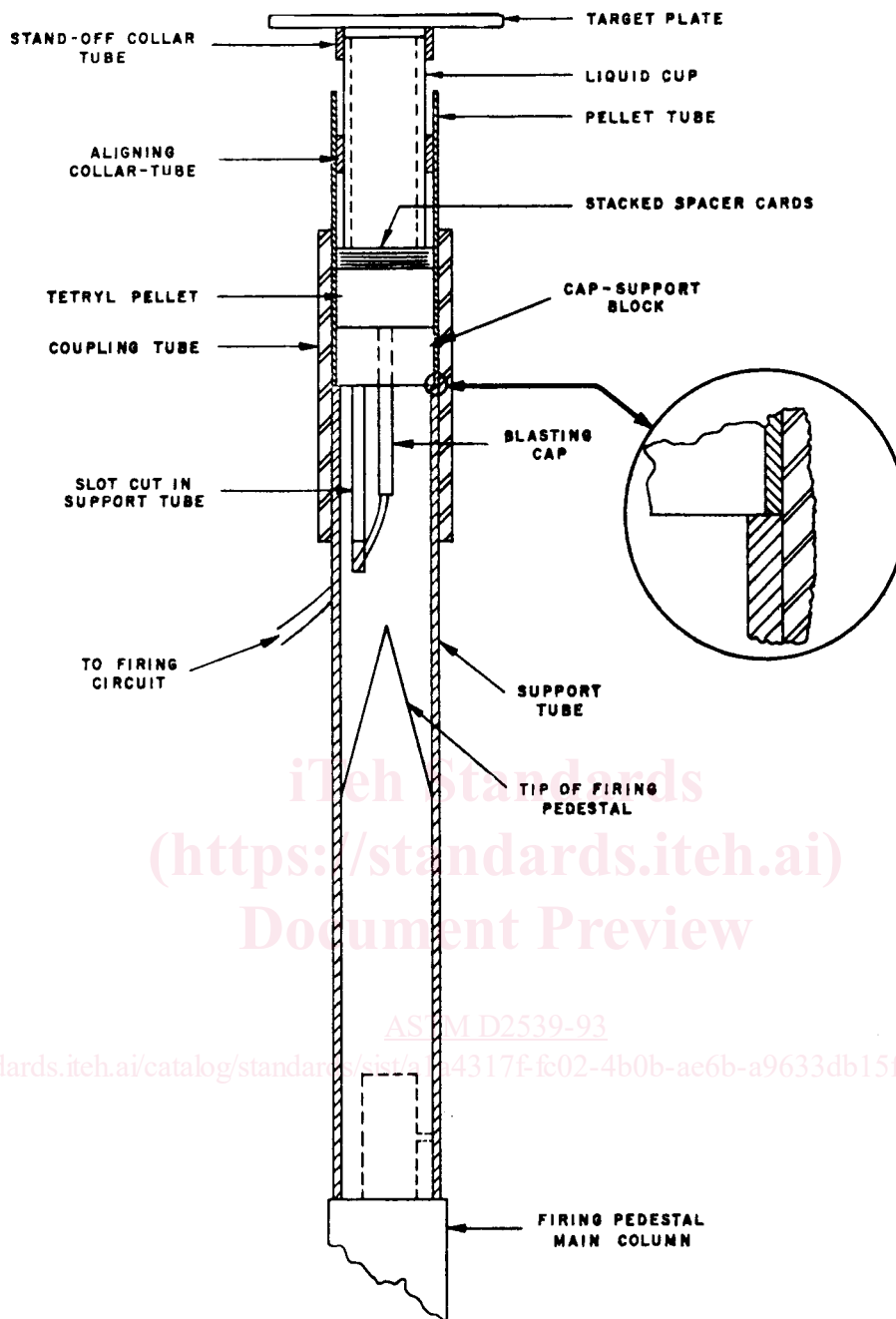

FIG. 2 Test Assembly Showing Cardboard Tubes Sectioned

pattern shall be carried forward until a reversal in trend occurs with a change of only one card. The ensuing shots shall be fired by increasing the card number by one card after every detonation, decreasing it by one card after every failure. As successive shots are made in this manner, a symmetrical distribution of detonations and failures soon becomes evident, having as its midpoint the desired sensitivity value.

6.2 An example of what can be encountered experimentally is given in Table 1. Table 2 presents the same data in an arrangement more easily interpreted; a 50 % point of 20 cards is clearly indicated.

6.3 For materials that have a very sharp cut-off, an alternative abbreviated procedure can be used. After a positive and a

negative test have been obtained which differ by only one card, let  $N$  = the number of cards corresponding to this positive test and  $N + 1$  = the number of cards corresponding to this negative test.

6.4 A basic test pattern consisting of four tests shall be established by making one additional shot at both  $N$  and  $N + 1$  cards. The four possible results are shown in Table 3. If patterns I or II are obtained, no further testing shall be required to establish the 50 % point, and the results are as shown. If patterns III or IV are obtained, two supplementary shots will be needed at a particular card value to determine the 50 % point. (One of these may already have been made in the previous sequence.) These supplementary tests and the corresponding



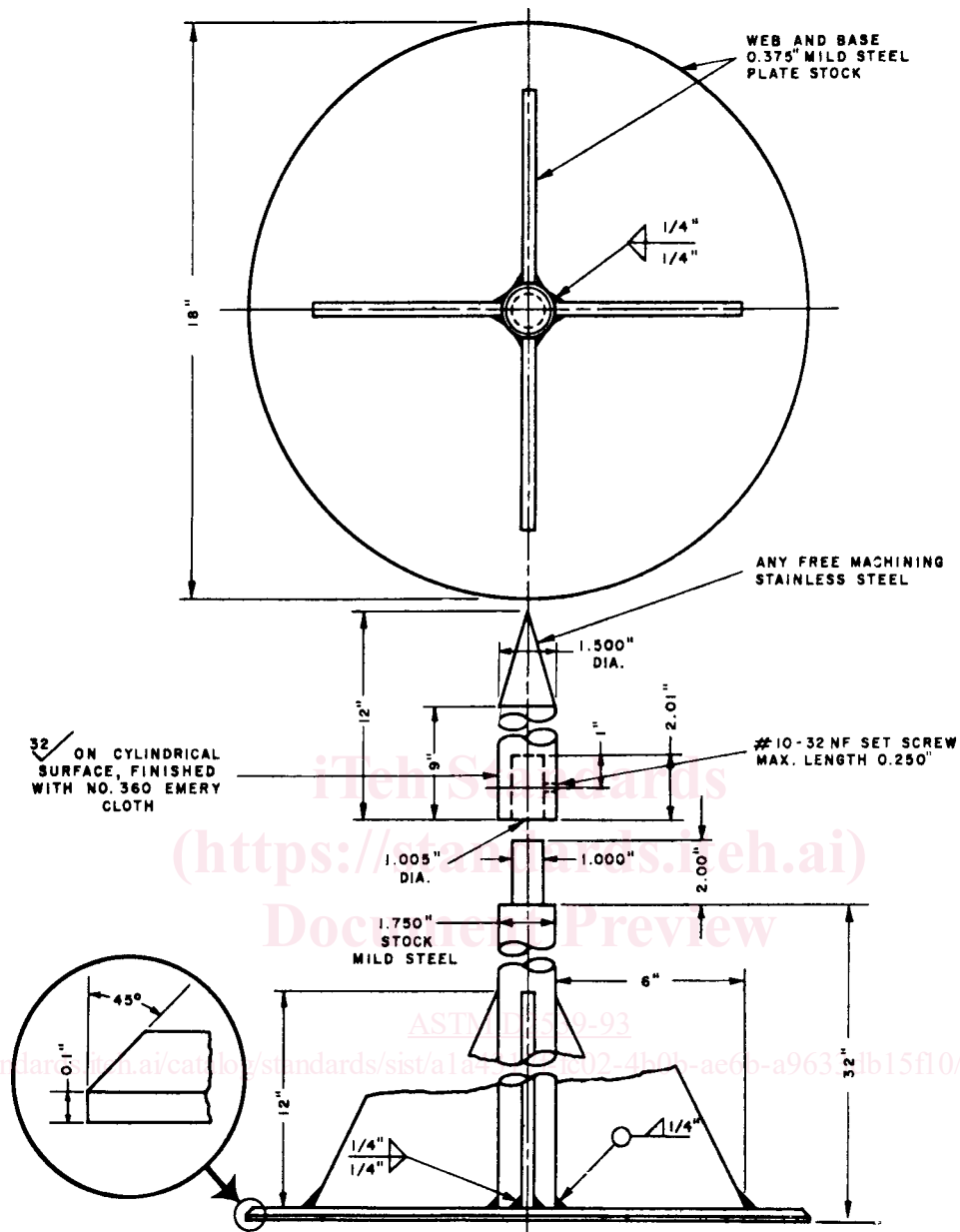

FIG. 3 Firing Pedestal

values of the 50 % point are given in Table 3.

6.5 Two sample test procedures are given in Table 4. In example "A," two supplementary tests are necessary after the basic test configuration is established. In "B," one supplementary test is made before, and one after the basic test configuration is obtained.

6.6 Because the test apparatus for card-gap determinations shall be outdoors, ambient temperatures and sample temperatures are frequently below the desired range. Simple, yet effective, temperature control can be provided by means of insulated electrical heating tape wrapped around the sample cup in conjunction with a thermocouple and relay. The expense of making the heating tape an expendable item can be reduced by fabricating the tape from  $\frac{3}{16}$  by 0.003-in. (4.8 by 0.08-mm) Nichrome ribbon and  $\frac{1}{4}$ -in. (6.4-mm) glass fiber sleeving.

### 7. Calibration

7.1 Comparison of sensitivity data from several sources will be much better justified if each investigator "calibrates" his system by running sensitivity determinations periodically on a series of standard liquid propellants. Agreement among the absolute values of card-gap sensitivity for the series of reference liquid propellants is not expected to be exact, especially when temperature control is not provided, but the order in which the sensitivity values fall should not be different from the accepted order. A reference series of liquid propellants can be as follows (in increasing order of card-gap values): unsymmetrical dimethylhydrazine (or hydrazine) < nitromethane < 80 % nitromethane-20 % tetranitromethane < 40 % nitromethane-60 % tetranitromethane < 90 % nitromethane-10 % ethylenediamine.