

Standard Test Method for Foaming Properties of Surface-Active Agents¹

This standard is issued under the fixed designation D 1173; the number immediately following the designation indicates the year of original adoption or, in the case of revision, the year of last revision. A number in parentheses indicates the year of last reapproval. A superscript epsilon (ϵ) indicates an editorial change since the last revision or reapproval.

1. Scope

1.1 This test method covers the determination of the foaming properties of surface-active agents as defined in Terminology D 459. This test method is applicable under limited and controlled conditions, but does not necessarily yield information correlating with specific end uses.

1.2 *This standard does not purport to address all of the safety concerns, if any, associated with its use. It is the responsibility of the user of this standard to establish appropriate safety and health practices and determine the applicability of regulatory limitations prior to use.*

2. Referenced Documents

2.1 ASTM Standards:

D 459 Terminology Relating To Soaps and Other Detergents²

3. Apparatus

3.1 *Pipet*—The pipet (Fig. 1) shall be constructed from standard-wall, chemically resistant glass tubing having the following dimensions: for the bulb, 45 ± 1.5 mm outside diameter; for the lower stem, 7 ± 0.5 mm outside diameter. The upper stem shall be constructed to contain a solid-stopper, straight bore, No. 2, standard-taper stopcock having a 2-mm bore and stems 8 mm in outside diameter. Both the upper and lower seals of the bulb to the stems shall be hemispherical in shape. The lower stem shall be 60 ± 2 mm in length from the point of attachment to the bulb and shall contain an orifice sealed into the lower end. The orifice shall be constructed from precision bore tubing having an inside diameter of 2.9 ± 0.02 mm and a length of 10 ± 0.05 mm, with both ends ground square. The orifice shall have an outside diameter so as to fit snugly into the lower stem and form a secure seal to the stem when heated with a sharp pointed flame in the blow torch. The pipet shall be calibrated to contain 200 ± 0.2 mL at 20°C . The calibration mark shall be on the upper stem at least 15 mm below the barrel of the stopcock and shall completely encircle the stem.

3.2 *Receiver*—The receiver (Fig. 2) shall be constructed

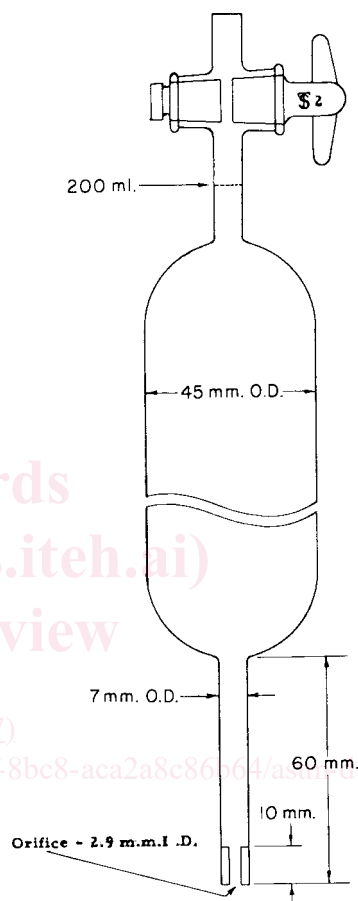

FIG. 1 Foam Pipet

from standard-wall, chemically resistant glass tubing having an internal diameter of 50 ± 0.8 mm, with one end constricted and sealed to a straight-bore, solid-plug, standard-taper No. 6 stopcock having a 6-mm bore and 12-mm stems. The receiver shall have three calibration marks which shall completely encircle the tube. The first mark shall be at the 50-mL point, shall be measured with the stopcock closed, and shall not be on any curved portion of the constriction. The second mark shall be at the 250-mL point, and the third mark at a distance of 90 ± 0.5 cm above the 50-mL mark. The receiver tube shall be mounted in a standard-wall tubular water jacket, having an external diameter of not less than 70 mm, fitted with inlet and outlet connections. The jacket may be attached to the receiver with rubber stoppers or may be sealed at the top and bottom.

¹ This test method is under the jurisdiction of ASTM Committee D-12 on Soaps and Other Detergents and is the direct responsibility of Subcommittee D12.15 on Physical Testing.

Current edition approved Sept. 15, 1953. Published November 1953. Originally published as D 1173 – 51 T. Last previous edition D 1173 – 51 T.

² *Annual Book of ASTM Standards*, Vol 15.04.