

INTERNATIONAL
STANDARD

ISO
11234

First edition
1995-12-15

**Rubber compounding ingredients —
Carbon black (pelletized) — Determination
of dust content**

iTeh STANDARD PREVIEW

(standards.iteh.ai)

*Ingrédients de mélange du caoutchouc — Noir de carbone (en
granules) — Détermination de la teneur en poussière*

ISO 11234:1995

<https://standards.iteh.ai/catalog/standards/sist/93dccc9-1811-4b08-8f78-3df5e543cbb5/iso-11234-1995>



Reference number
ISO 11234:1995(E)

Foreword

ISO (the International Organization for Standardization) is a worldwide federation of national standards bodies (ISO member bodies). The work of preparing International Standards is normally carried out through ISO technical committees. Each member body interested in a subject for which a technical committee has been established has the right to be represented on that committee. International organizations, governmental and non-governmental, in liaison with ISO, also take part in the work. ISO collaborates closely with the International Electrotechnical Commission (IEC) on all matters of electrotechnical standardization.

Draft International Standards adopted by the technical committees are circulated to the member bodies for voting. Publication as an International Standard requires approval by at least 75 % of the member bodies casting a vote.

International Standard ISO 11234 was prepared by Technical Committee ISO/TC 45, *Rubber and rubber products*, Subcommittee SC 3, *Raw materials (including latex) for use in the rubber industry*.

ISO 11234:1995
<https://standards.iteh.ai/catalog/standards/sist/93dccc9-1811-4b08-8f78-3df5e543cbb5/iso-11234-1995>

© ISO 1995

All rights reserved. Unless otherwise specified, no part of this publication may be reproduced or utilized in any form or by any means, electronic or mechanical, including photocopying and microfilm, without permission in writing from the publisher.

International Organization for Standardization
Case Postale 56 • CH-1211 Genève 20 • Switzerland

Printed in Switzerland

Introduction

The fines content of pelletized carbon blacks, as measured in accordance with ISO 1435:1988, *Rubber compounding ingredients — Carbon black (pelletized) — Determination of fines content*, encompasses not only the fines but also any micro-pellets having a diameter of less than 125 µm which may be present. Consequently, ISO 1435 is not specific for the determination of the dust content. Pelletized carbon blacks may contain a considerable proportion of micro-pellets.

iTeh STANDARD PREVIEW
(standards.iteh.ai)

ISO 11234:1995

<https://standards.iteh.ai/catalog/standards/sist/93dccc9-1811-4b08-8f78-3df5e543cbb5/iso-11234-1995>

iTeh STANDARD PREVIEW
This page intentionally left blank
(standards.iteh.ai)

ISO 11234:1995

<https://standards.iteh.ai/catalog/standards/sist/9f3dccc9-1811-4b08-8f78-3df5e543cbb5/iso-11234-1995>

Rubber compounding ingredients — Carbon black (pelletized) — Determination of dust content

WARNING — Persons using this International Standard should be familiar with normal laboratory practice. This standard does not purport to address all of the safety problems, if any, associated with its use. It is the responsibility of the user to establish appropriate safety and health practices and to ensure compliance with any national regulatory conditions.

1 Scope

This International Standard specifies a method for determining the dust content of pelletized carbon blacks for use in the industry.

This method permits a differentiation to be made between micro-pellets and dust, and is applicable to all pelletized rubber-grade carbon blacks, more particularly to those pelletized by the dry process which frequently have smaller pellet sizes than their wet-pelletized counterparts.

2 Normative references

The following standards contain provisions which, through reference in this text, constitute provisions of this International Standard. At the time of publication, the editions indicated were valid. All standards are subject to revision, and parties to agreements based on this International Standard are encouraged to investigate the possibility of applying the most recent editions of the standards indicated below. Members of IEC and ISO maintain registers of currently valid International Standards.

ISO 383:1976, *Laboratory glassware — Interchangeable conical ground joints.*

ISO 1124:1988, *Rubber compounding ingredients — Carbon black shipment sampling procedures.*

ISO 1126:1992, *Rubber compounding ingredients — Carbon black — Determination of loss on heating.*

3 Principle

A test portion of carbon black is fluidized on a sintered-glass filter by means of a gas flow. Dust is carried with the gas flow, is separated from the gas in a cyclone, and is finally weighed.

4 Significance and use

The dust content of a carbon black is related to the ability of the product to flow freely and, to a certain extent, its dispersion characteristics. However, in view of the many other variables influencing dispersion and handling, the significance of the dust content must be determined by the user. The dust content can be a relevant parameter in the context of the working-place environment.

5 Apparatus

5.1 Dust-separation equipment, as illustrated in figure 1, and consisting of the elements described in 5.1.1 to 5.1.4.

5.1.1 Sintered-glass filter, type 0.0 (pore size 250 µm to 500 µm).

5.1.2 Glass tube, internal diameter 32 mm, mounted vertically.

5.1.3 Glass cyclones.

5.1.4 Glass collectors, internal diameter 18 mm.

5.2 Source of dry, oil-free compressed air or nitrogen.

5.3 Pressure-regulation valve.

5.4 Flowmeter, range 5 dm³/min to 25 dm³/min.

5.5 Analytical balance, sensitivity 0,1 mg.

5.6 Oven, capable of maintaining a temperature of 105 °C ± 2 °C or 125 °C ± 2 °C.

5.7 Usual ancillary laboratory equipment, including a stopwatch.

5.8 Elements 5.1.1 to 5.1.3 are assembled using two ground-glass connections located at the bottom and the top of tube (5.1.2). Elements 5.1.3 and 5.1.4 (flexibly connected by a rubber seal) are only separated for cleaning purposes. The flexible tubing connecting elements 5.4 and 5.1.1 must fit the corresponding outlet and inlet diameters, the other dimensions being immaterial.

6 Procedure

6.1 Before starting the determination, connect the filter (5.1.1), the vertical tube (5.1.2) and the cyclone/collector assembly (5.1.3 and 5.1.4) to the source of dry compressed gas (5.2) and, using the pressure-regulation valve (5.3), adjust the gas flow to 14,4 dm³/min ± 0,5 dm³/min, which corresponds to a gas speed of 0,30 m/s in the vertical glass tube.

6.2 Cut off the gas supply and disconnect the sintered-glass filter from the vertical glass tube.

6.3 Following the procedure specified in ISO 1126, dry an adequate quantity of the carbon black sample under test for no less than 1 h at 105 °C or, better, at 125 °C. When the carbon black is completely dry, cool it to ambient temperature in a desiccator and store it there until weighing.

6.4 Weigh out 5 g ± 0,5 g of the dried carbon black to the nearest 1 mg using the analytical balance (5.5) and immediately pour this test portion into the sintered-glass filter (5.1.1).

6.5 Connect the sintered-glass filter to the vertical tube.

6.6 Open the gas valve, verify that the gas flow is steady at 14,4 dm³/min, and allow the gas to flow for 5 min ⁺¹⁰₀ s.

6.7 Stop the gas flow, disconnect the glass cyclones and weigh them to the nearest milligram.

6.8 Clean carefully the cyclones (and collectors), and reweigh them to the nearest milligram.

NOTE 1 A vacuum cleaner can be useful for cleaning up after this operation.

7 Expression of results

Calculate the dust content, expressed as a percentage by mass, using the formula

$$\frac{m_2 - m_1}{m_0} \times 100$$

where

m_0 is the mass, in grams, of the test portion of dried carbon black;

m_1 is the mass, in grams, of the empty glass cyclones and collectors;

m_2 is the mass, in grams, of the glass cyclones and collectors with the carbon black dust collected.

8 Test report

The test report shall include the following particulars:

- a reference to this International Standard;
- all details necessary to identify the sample;
- the results, rounded to the nearest 0,1 %;
- any unusual features noted during the determination;
- any operation not included in this International Standard or regarded as optional.

Dimensions in millimetres

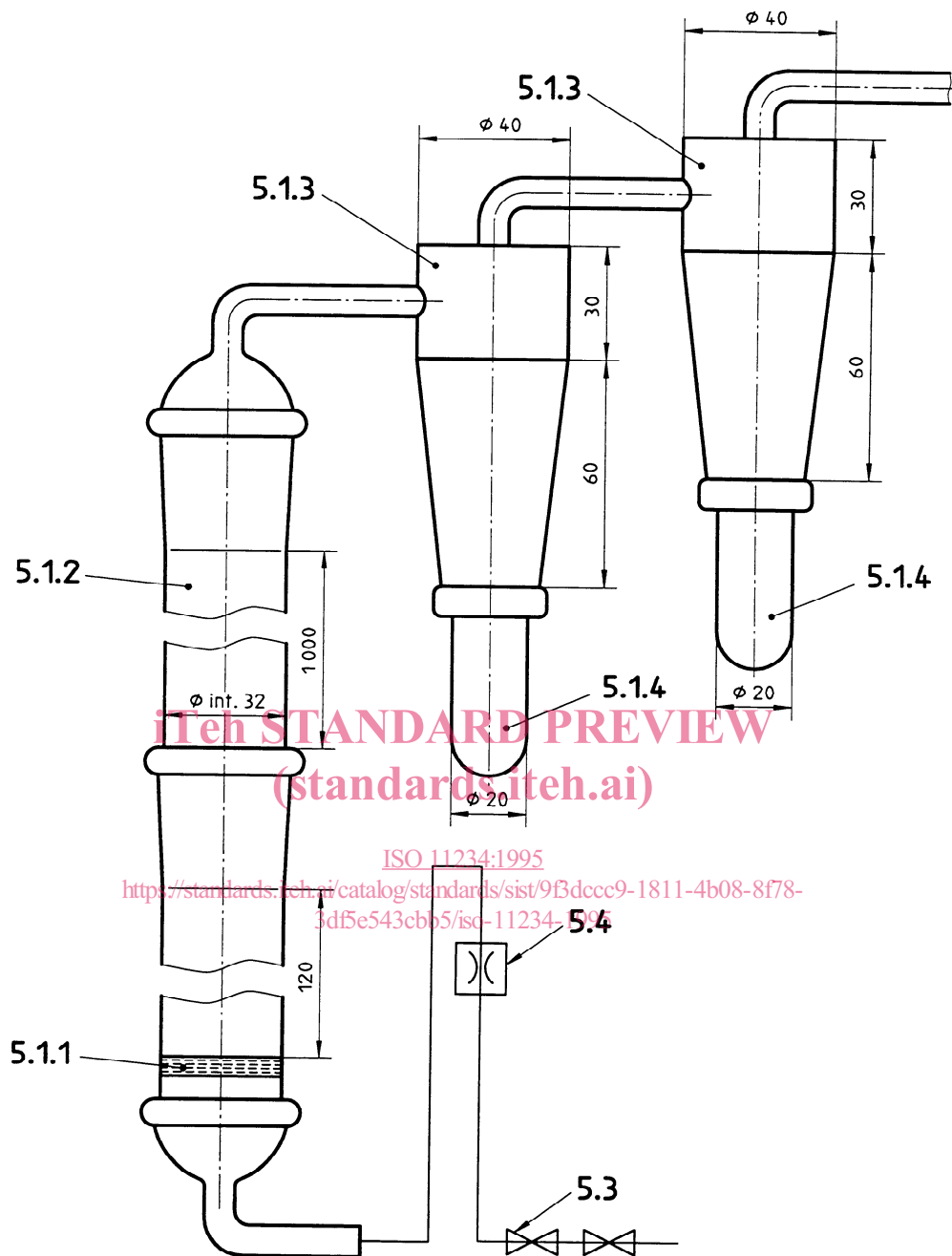
**Key:**

- 5.1.1 Sintered-glass filter
- 5.1.2 Glass tube
- 5.1.3 Glass cyclone
- 5.1.4 Glass collector
- 5.3 Pressure-regulation valve
- 5.4 Flowmeter

NOTE — All ground-glass joints shall conform to ISO 383.

Figure 1 — Dust-separation equipment

iTeh STANDARD PREVIEW (standards.iteh.ai)

ISO 11234:1995

<https://standards.iteh.ai/catalog/standards/sist/9f3dccc9-1811-4b08-8f78-3df5e543cbb5/iso-11234-1995>

ICS 83.040.20

Descriptors: rubber industry, rubber, ingredients, pelletized materials, carbon black, tests, determination of content, dust.

Price based on 3 pages
