

INTERNATIONAL STANDARD

NORME INTERNATIONALE

**Fibre optic interconnecting devices and passive components – Basic test and measurement procedures –
Part 2-7: Tests – Bending moment**

**Dispositifs d'interconnexion et composants passifs à fibres optiques –
Procédures fondamentales d'essais et de mesures –
Partie 2-7: Essais – Moment de flexion**



THIS PUBLICATION IS COPYRIGHT PROTECTED
Copyright © 2013 IEC, Geneva, Switzerland

All rights reserved. Unless otherwise specified, no part of this publication may be reproduced or utilized in any form or by any means, electronic or mechanical, including photocopying and microfilm, without permission in writing from either IEC or IEC's member National Committee in the country of the requester.
If you have any questions about IEC copyright or have an enquiry about obtaining additional rights to this publication, please contact the address below or your local IEC member National Committee for further information.

Droits de reproduction réservés. Sauf indication contraire, aucune partie de cette publication ne peut être reproduite ni utilisée sous quelque forme que ce soit et par aucun procédé, électronique ou mécanique, y compris la photocopie et les microfilms, sans l'accord écrit de la CEI ou du Comité national de la CEI du pays du demandeur.
Si vous avez des questions sur le copyright de la CEI ou si vous désirez obtenir des droits supplémentaires sur cette publication, utilisez les coordonnées ci-après ou contactez le Comité national de la CEI de votre pays de résidence.

IEC Central Office
3, rue de Varembe
CH-1211 Geneva 20
Switzerland

Tel.: +41 22 919 02 11
Fax: +41 22 919 03 00
info@iec.ch
www.iec.ch

About the IEC

The International Electrotechnical Commission (IEC) is the leading global organization that prepares and publishes International Standards for all electrical, electronic and related technologies.

About IEC publications

The technical content of IEC publications is kept under constant review by the IEC. Please make sure that you have the latest edition, a corrigenda or an amendment might have been published.

Useful links:

IEC publications search - www.iec.ch/searchpub

The advanced search enables you to find IEC publications by a variety of criteria (reference number, text, technical committee,...).

It also gives information on projects, replaced and withdrawn publications.

IEC Just Published - webstore.iec.ch/justpublished

Stay up to date on all new IEC publications. Just Published details all new publications released. Available on-line and also once a month by email.

Electropedia - www.electropedia.org

The world's leading online dictionary of electronic and electrical terms containing more than 30 000 terms and definitions in English and French, with equivalent terms in additional languages. Also known as the International Electrotechnical Vocabulary (IEV) on-line.

Customer Service Centre - webstore.iec.ch/csc

If you wish to give us your feedback on this publication or need further assistance, please contact the Customer Service Centre: csc@iec.ch.

A propos de la CEI

La Commission Electrotechnique Internationale (CEI) est la première organisation mondiale qui élabore et publie des Normes internationales pour tout ce qui a trait à l'électricité, à l'électronique et aux technologies apparentées.

A propos des publications CEI

Le contenu technique des publications de la CEI est constamment revu. Veuillez vous assurer que vous possédez l'édition la plus récente, un corrigendum ou amendement peut avoir été publié.

Liens utiles:

Recherche de publications CEI - www.iec.ch/searchpub

La recherche avancée vous permet de trouver des publications CEI en utilisant différents critères (numéro de référence, texte, comité d'études,...).

Elle donne aussi des informations sur les projets et les publications remplacées ou retirées.

Just Published CEI - webstore.iec.ch/justpublished

Restez informé sur les nouvelles publications de la CEI. Just Published détaille les nouvelles publications parues. Disponible en ligne et aussi une fois par mois par email.

Electropedia - www.electropedia.org

Le premier dictionnaire en ligne au monde de termes électroniques et électriques. Il contient plus de 30 000 termes et définitions en anglais et en français, ainsi que les termes équivalents dans les langues additionnelles. Egalement appelé Vocabulaire Electrotechnique International (VEI) en ligne.

Service Clients - webstore.iec.ch/csc

Si vous désirez nous donner des commentaires sur cette publication ou si vous avez des questions contactez-nous: csc@iec.ch.



INTERNATIONAL STANDARD

NORME INTERNATIONALE

Fibre optic interconnecting devices and passive components – Basic test and measurement procedures – Part 2-7: Tests – Bending moment

Dispositifs d'interconnexion et composants passifs à fibres optiques – Procédures fondamentales d'essais et de mesures – Partie 2-7: Essais – Moment de flexion

INTERNATIONAL
ELECTROTECHNICAL
COMMISSION

COMMISSION
ELECTROTECHNIQUE
INTERNATIONALE

PRICE CODE
CODE PRIX

K

ICS 33.180.20

ISBN 978-2-83220-790-1

**Warning! Make sure that you obtained this publication from an authorized distributor.
Attention! Veuillez vous assurer que vous avez obtenu cette publication via un distributeur agréé.**

CONTENTS

FOREWORD.....	3
1 Scope.....	5
2 Normative references	5
3 General description	5
4 Apparatus.....	5
4.1 Design for a 1 piece or 3 piece DUT	5
4.2 Design for a 2 piece DUT	6
4.3 Optical measurements.....	7
5 Procedure.....	7
5.1 Preconditioning	7
5.2 Initial examinations and measurements	7
5.3 Conditioning for a 1 piece or 3 piece DUT.....	7
5.4 Conditioning for a 2 piece DUT.....	7
5.5 Recovery.....	8
5.6 Final examinations and measurements.....	8
6 Severity.....	8
7 Details to be specified	9
Annex A (informative) Example for a bending moment test method for splices	10
Figure 1 – Test apparatus to apply a bending moment to a 1 piece or 3 piece DUT.....	6
Figure 2 – Test apparatus to apply a bending moment to a 2 piece DUT.....	7
Figure A.1 – Example for a bending moment test set-up for splices.....	10
Table 1 – Relationship between severities, performance categories and DUT	8
Table 2 – Severities for an 1 piece or 3 piece DUT	9
Table 3 – Severities for an 2 piece DUT.....	9

INTERNATIONAL ELECTROTECHNICAL COMMISSION

**FIBRE OPTIC INTERCONNECTING DEVICES
AND PASSIVE COMPONENTS –
BASIC TEST AND MEASUREMENT PROCEDURES –****Part 2-7: Tests – Bending moment**

FOREWORD

- 1) The International Electrotechnical Commission (IEC) is a worldwide organization for standardization comprising all national electrotechnical committees (IEC National Committees). The object of IEC is to promote international co-operation on all questions concerning standardization in the electrical and electronic fields. To this end and in addition to other activities, IEC publishes International Standards, Technical Specifications, Technical Reports, Publicly Available Specifications (PAS) and Guides (hereafter referred to as "IEC Publication(s)"). Their preparation is entrusted to technical committees; any IEC National Committee interested in the subject dealt with may participate in this preparatory work. International, governmental and non-governmental organizations liaising with the IEC also participate in this preparation. IEC collaborates closely with the International Organization for Standardization (ISO) in accordance with conditions determined by agreement between the two organizations.
- 2) The formal decisions or agreements of IEC on technical matters express, as nearly as possible, an international consensus of opinion on the relevant subjects since each technical committee has representation from all interested IEC National Committees.
- 3) IEC Publications have the form of recommendations for international use and are accepted by IEC National Committees in that sense. While all reasonable efforts are made to ensure that the technical content of IEC Publications is accurate, IEC cannot be held responsible for the way in which they are used or for any misinterpretation by any end user.
- 4) In order to promote international uniformity, IEC National Committees undertake to apply IEC Publications transparently to the maximum extent possible in their national and regional publications. Any divergence between any IEC Publication and the corresponding national or regional publication shall be clearly indicated in the latter.
- 5) IEC itself does not provide any attestation of conformity. Independent certification bodies provide conformity assessment services and, in some areas, access to IEC marks of conformity. IEC is not responsible for any services carried out by independent certification bodies.
- 6) All users should ensure that they have the latest edition of this publication.
- 7) No liability shall attach to IEC or its directors, employees, servants or agents including individual experts and members of its technical committees and IEC National Committees for any personal injury, property damage or other damage of any nature whatsoever, whether direct or indirect, or for costs (including legal fees) and expenses arising out of the publication, use of, or reliance upon, this IEC Publication or any other IEC Publications.
- 8) Attention is drawn to the Normative references cited in this publication. Use of the referenced publications is indispensable for the correct application of this publication.
- 9) Attention is drawn to the possibility that some of the elements of this IEC Publication may be the subject of patent rights. IEC shall not be held responsible for identifying any or all such patent rights.

International Standard IEC 61300-2-7 has been prepared by subcommittee 86B: Fibre optic interconnecting devices and passive components, of IEC technical committee 86: Fibre optics.

This second edition cancels and replaces the first edition published in 1995. It constitutes a technical revision.

This edition includes the following significant technical changes with respect to the previous edition:

- a) a complete reconsideration of the entire document, including additional normative references;
- b) clarification of the device under test (DUT);
- c) clarification of the relationship between severities, performance categories and the DUT.

The text of this standard is based on the following documents:

FDIS	Report on voting
86B/3579A/FDIS	86B/3621/RVD

Full information on the voting for the approval of this standard can be found in the report on voting indicated in the above table.

This publication has been drafted in accordance with the ISO/IEC Directives, Part 2.

A list of all parts in IEC 61300 series, published under the general title *Fibre optic interconnecting and passive components – Basic test and measurement procedures*, can be found on the IEC website.

The committee has decided that the contents of this publication will remain unchanged until the stability date indicated on the IEC web site under "http://webstore.iec.ch" in the data related to the specific publication. At this date, the publication will be

- reconfirmed,
- withdrawn,
- replaced by a revised edition, or
- amended.

iTeh STANDARD PREVIEW
(standards.iteh.ai)

[IEC 61300-2-7:2013](https://standards.iteh.ai/catalog/standards/sist/a0fc3c46-969d-4f62-b903-cf31f5df50ac/iec-61300-2-7-2013)

<https://standards.iteh.ai/catalog/standards/sist/a0fc3c46-969d-4f62-b903-cf31f5df50ac/iec-61300-2-7-2013>

FIBRE OPTIC INTERCONNECTING DEVICES AND PASSIVE COMPONENTS – BASIC TEST AND MEASUREMENT PROCEDURES –

Part 2-7: Tests – Bending moment

1 Scope

This part of IEC 61300 details a procedure for determining the suitability of a fibre optic device to withstand the environmental condition of a bending moment which may occur in actual use, storage and/or transport. The test is primarily intended to permit the observation of effects of a bending moment. The bending moment may result in effects that would destroy functional utility, cause loss of physical strength, and cause changes in other important mechanical properties. Degradation of optical properties may also occur. The specimen may be a component, a connector set, a splice or other device combination intended for fibre optic usage.

2 Normative references

The following documents, in whole or in part, are normatively referenced in this document and are indispensable for its application. For dated references, only the edition cited applies. For undated references, the latest edition of the referenced document (including any amendments) applies.

IEC 61300-3-1, *Fibre optic interconnecting devices and passive components – Basic test and measurement procedures – Part 3-1: Examinations and measurements – Visual examination*

IEC 61300-3-3, *Fibre optic interconnecting devices and passive components – Basic tests and measurement procedures – Part 3-3: Examinations and measurements – Active monitoring of changes in attenuation and return loss*

IEC 61300-3-4, *Fibre optic interconnecting devices and passive components – Basic tests and measurement procedures – Part 3-4: Examinations and measurements – Attenuation*

3 General description

The specimen is placed in an apparatus and subjected to a bending moment which is maintained at a given temperature for a specified duration, as specified in the relevant specification. The bending moment is smoothly applied to the specimen so as to bend its longitudinal axis.

4 Apparatus

4.1 Design for a 1 piece or 3 piece DUT

This design is suitable for specimens which consist of one part, like splices.

The apparatus consists of the following elements:

- a) two steel rods placed at an appropriate distance in from the extreme ends of the DUT;

- b) a steel finger with a defined endface radius which is placed in the middle of the supported DUT;
- c) a force generator capable of smoothly applying the specified force at the specified rate to the steel finger;
- d) an optional clamping device to fix the DUT;
- e) additional measuring equipment.

If the specimen has to operate during the test, then additional equipment and operating conditions shall be specified in the relevant specification.

An example of an apparatus is shown in Figure 1.

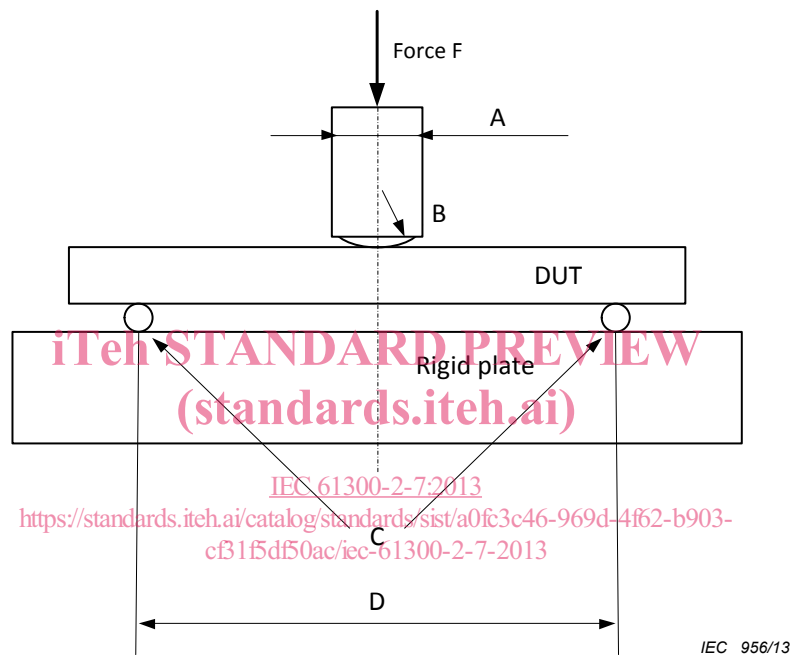

Figure 1 – Test apparatus to apply a bending moment to a 1 piece or 3 piece DUT

4.2 Design for a 2 piece DUT

This design is suitable for specimens which consist of two parts, like connector sets. The two parts are joined together.

The apparatus consists of the following elements:

- a) a clamping device on which the DUT, Part 1 is placed;
- b) a steel finger with a defined endface radius which is placed at the end of the DUT, Part 2;
- c) a force generator capable of smoothly applying the specified force at the specified rate to the steel finger;
- d) additional measuring equipment.

If the specimen has to operate during the test, then additional equipment and operating conditions shall be specified in the relevant specification.

An example of an apparatus is shown in Figure 2.

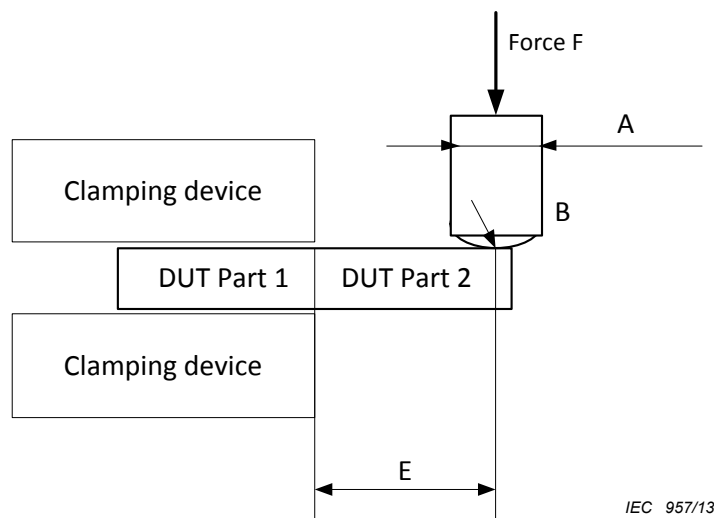

Figure 2 – Test apparatus to apply a bending moment to a 2 piece DUT

4.3 Optical measurements

Where active monitoring is specified, measuring equipment specified in IEC 61300-3-3 shall be connected to the specimen for monitoring optical performance during the test. The optical source and detector used to measure changes in attenuation shall comply with those specified in IEC 61300-3-4.

(standards.iteh.ai)

5 Procedure

[IEC 61300-2-7:2013](https://standards.iteh.ai/catalog/standards/sist/a0fc3c46-969d-4f62-b903-c31f5df50ac/iec-61300-2-7-2013)

5.1 Preconditioning

<https://standards.iteh.ai/catalog/standards/sist/a0fc3c46-969d-4f62-b903-c31f5df50ac/iec-61300-2-7-2013>

Maintain the specimen under standard atmospheric condition (room temperature condition) for a minimum of 2 h.

Clean the specimen according to the manufacturer's instructions.

5.2 Initial examinations and measurements

Complete initial examinations and measurements as required by the relevant specification.

5.3 Conditioning for a 1 piece or 3 piece DUT

- a) Apply the DUT on the steel rods and securely clamp them, if necessary.
- b) Smoothly apply a force to the steel finger at the middle of the DUT and at the values specified in the relevant specification.
- c) Maintain the force for 10 s minimum.
- d) If required in the relevant specification, optical measurements (i.e. attenuation, return loss) shall be performed and the results shall be collected.
- e) Where optical measurements are required during the test, measurements shall be made in accordance with IEC 61300-3-3. The relevant specification shall define the measurements and period(s) during testing after which they shall be carried out. The measurements shall not cause any change to the test conditions.

5.4 Conditioning for a 2 piece DUT

- a) Properly join the two parts of the DUT together, according to the manufacturer's instruction.

- b) Securely clamp DUT, Part 1.
- c) Smoothly apply a force to DUT, Part 2 at the specified point of application and at the values specified in the relevant specification.
- d) Maintain the force for 10 s minimum.
- e) If required in the relevant specification, optical measurements (i.e. attenuation, return loss) shall be performed and the results shall be collected.
- f) Where optical measurements are required during the test, measurements shall be made in accordance with IEC 61300-3-3. The relevant specification shall define the measurements and period(s) during testing after which they shall be carried out. The measurements shall not cause any change to the test conditions.

5.5 Recovery

Allow the specimen to remain under standard atmospheric conditions for a period of 10 min.

5.6 Final examinations and measurements

On completion of the test, remove all fixtures. Clean the mechanical and optical alignment parts of the specimen according to the manufacturer's instructions. Take final measurements as required by the relevant specification. If specified, visually examine the specimen in accordance with IEC 61300-3-1 and take any measurements specified to ensure that there is no permanent damage.

6 Severity

iTeh STANDARD PREVIEW
(standards.iteh.ai)

The severities for both methods are determined as indicated in Table 1.

IEC 61300-2-7:2013
<https://standards.iteh.ai/catalog/standards/sist/a0fc3c46-969d-4f62-b903-c8315d850ac/iec-61300-2-7-2013>
Table 1 – Relationship between severities, performance categories and DUT

DUT	Operating environment	Force F N	Remark
1 piece or 3 piece DUT: Mechanical splices and closures	Controlled C	–	
	Uncontrolled U and O	2	For mechanical splices
		10	For closures
	Extreme E	–	
	Aerial A	–	
	Ground G	–	
Subterranean S	–		
2 piece DUT: Connectors	Controlled C	–	
	Uncontrolled U and O	10	
	Extreme E	–	

The severity shall be given in the relevant specification. The severities according to Table 2 or Table 3 may be used for the procedure.

Table 2 – Severities for an 1 piece or 3 piece DUT

Force F N	Diameter A mm	Radius B mm	Diameter C mm	Distance D mm	Remark
2	10	30	5	The point of application shall be at the ends of the rigid part of the DUT minus 2 mm	For mechanical splices
10	10	30	5	The point of application shall be at the ends of the rigid part of the DUT minus 2 mm	For closures

Table 3 – Severities for an 2 piece DUT

Force F N	Diameter A mm	Radius B mm	Distance E mm
10	10	30	The point of application shall be at the end of the rigid part of the DUT part two minus 2 mm

7 Details to be specified

The following details, as applicable, shall be specified in the relevant specification:

- a) Force F
- b) Diameter A
- c) Diameter B
- d) Diameter C
- e) Distance D (if applicable)
- f) Distance E (if applicable)
- g) Direction of the force relative to the specimen
- h) Applied load speed or feed speed up to the force F
- i) Duration of exposure
- j) Specific mounting structures
- k) Specimen optically functioning
- l) Initial examinations and measurements and performance requirements
- m) Examinations and measurements during test and performance requirements
- n) Final examinations and measurements and performance requirements
- o) Deviations from test procedure
- p) Additional pass/fail criteria

iTeh STANDARD PREVIEW
(standards.iteh.ai)

[IEC 61300-2-7:2013](https://standards.iteh.ai/catalog/standards/sist/a0fc3c46-969d-4f62-b903-cf31f5df50ac/iec-61300-2-7-2013)

<https://standards.iteh.ai/catalog/standards/sist/a0fc3c46-969d-4f62-b903-cf31f5df50ac/iec-61300-2-7-2013>