

INTERNATIONAL
STANDARD

ISO
11276

First edition
1995-09-01

**Soil quality — Determination of pore water
pressure — Tensiometer method**

iTeh STANDARD PREVIEW
(standards.iteh.ai)

*Qualité du sol — Détermination de la pression d'eau dans les pores —
Méthode du tensiomètre*

ISO 11276:1995

<https://standards.iteh.ai/catalog/standards/sist/bc23a86b-9efc-4ec3-984b-70f7a7bdb7c1/iso-11276-1995>



Reference number
ISO 11276:1995(E)

Foreword

ISO (the International Organization for Standardization) is a worldwide federation of national standards bodies (ISO member bodies). The work of preparing International Standards is normally carried out through ISO technical committees. Each member body interested in a subject for which a technical committee has been established has the right to be represented on that committee. International organizations, governmental and non-governmental, in liaison with ISO, also take part in the work. ISO collaborates closely with the International Electrotechnical Commission (IEC) on all matters of electrotechnical standardization.

Draft International Standards adopted by the technical committees are circulated to the member bodies for voting. Publication as an International Standard requires approval by at least 75 % of the member bodies casting a vote.

International Standard ISO 11276 was prepared by Technical Committee ISO/TC 190, *Soil quality*, Subcommittee SC 5, *Physical methods*.

Annex A forms an integral part of this International Standard. Annexes B, C, D, E and F are for information only.

INTERNATIONAL STANDARD PREVIEW
(standards.iteh.ai)
ISO 11276:1995
<http://www.internationalstandards.org/public/iso/11276-1995>
<https://doi.org/10.31030/70f7a7bdb7c1/iso-11276-1995>

© ISO 1995

All rights reserved. Unless otherwise specified, no part of this publication may be reproduced or utilized in any form or by any means, electronic or mechanical, including photocopying and microfilm, without permission in writing from the publisher.

International Organization for Standardization
Case Postale 56 • CH-1211 Genève 20 • Switzerland

Printed in Switzerland

Soil quality — Determination of pore water pressure — Tensiometer method

1 Scope

This International Standard specifies methods for the determination of pore water pressure in both unsaturated and saturated soil using tensiometers. The methods are applicable for *in situ* pore water pressure measurements in the field, as well as for monitoring pore water pressure in, for example, plant containers or soil cores used in experimental procedures.

At normal atmospheric pressures, i.e. about 100 kPa, the application of these methods is limited to a range of pressures down to about – 85 kPa. The range is reduced at lower atmospheric pressures. Tensiometers will not function if sub-zero temperatures occur at the measurement depth. Their accuracy is influenced by soil and air temperature fluctuations. Tensiometer response time ranges from a few seconds to several days. To obtain reliable measurements under field conditions, tensiometers require frequent servicing.

A tensiometer provides point measurements of pore water pressure. To measure pore water pressure at different depths, several tensiometers will be necessary. In the field, replicate sets of instruments will be required if the spatial variability of the soil is to be allowed for.

2 Definitions

For the purposes of this International Standard, the following definitions apply.

NOTE 1 Additional definitions are given in E.2, for information only.

2.1 pore water pressure: The sum of matric and pneumatic pressures.

NOTES

2 Pore water pressure is also referred to as tensiometer pressure.

3 The pore water pressure represents the sum of the pressures due to interfacial forces acting between the water, air and solid phases of the soil (matric pressure), the part of the mass of overlying material not carried by the soil skeleton and therefore carried by the soil water (overburden pressure; this pressure is often considered as part of the matric pressure) and the local air pressure within the soil (pneumatic pressure). Under most circumstances, the overburden and pneumatic pressures are zero.

2.2 matric pressure: The amount of work that must be done in order to transport reversibly and isothermally an infinitesimal quantity of water, identical in composition to the soil water, from a pool at the elevation and the external gas pressure of the point under consideration, to the soil water at the point under consideration, divided by the volume of water transported.

2.3 pneumatic pressure: The amount of work that must be done in order to transport reversibly and isothermally an infinitesimal quantity of water, identical in composition to the soil water, from a pool at atmospheric pressure and at the elevation of the point under consideration, to a similar pool at an external gas pressure of the point under consideration, divided by the volume of water transported.

NOTE 4 Soil water pressure can be considered as a pressure equivalent of soil water potential. The same applies to the soil water head, the head equivalent of soil water potential.

The relationship between these is

$$\Psi \cdot \rho_w = p - h \cdot g \cdot \rho_w$$

where

Ψ	is the soil water potential, in joules per kilogram on a mass basis;
p	is the pressure equivalent of soil water potential, in joules per cubic metre on a volume basis ($1 \text{ J/m}^3 = 1 \text{ N/m}^2 = 1 \text{ Pa}$);
h	is the head equivalent of soil water potential, in joules per newton on a force basis ($1 \text{ J/N} = 1 \text{ m}$);
ρ_w	is the density of water, in kilograms per cubic metre;
g	is the acceleration due to gravity, in metres per second squared.

In this International Standard pressure equivalents and soil water potentials are used. The corresponding unit of measurement is the pascal (Pa). Table 1 provides conversions between soil water potential and its pressure and head equivalents.

3 Principle

A tensiometer comprises a porous cup that is permeable to water connected to a pressure-measuring device. The pores of the wall of the cup are small enough to prevent air passing through when it is wet. The porous cup is filled with water. When the cup is placed in the soil, water within the tensiometer flows through the porous wall to the soil, or soil water flows into the tensiometer, until the pressure of the water on both sides of the porous wall is equal. When equilibrium has been reached, the measured pressure of the water inside the tensiometer, after correction for the difference in height between the pressure sensor and the porous cup equals the pore water pressure of the soil water at the position of the porous cup.

4 Apparatus

4.1 Tensiometer, usually consisting of a porous cup, a connecting tube and/or a body tube, a pressure sensor and a mechanism for expelling any air which accumulates within the tensiometer. The details of the design depend primarily on whether the instrument is intended for field or indoor use and the type of pressure sensor employed; examples are shown in figure 1. Annex B provides information on materials for the construction of tensiometers and on their construction.

4.1.1 Porous cup, made of a porous material of air-entry value (i.e. the pressure required to force air through the water-saturated cup) larger in magnitude than the lowest pore water pressure to be measured and the known hydraulic conductivity. The material shall be rigid and not subject to degradation in soil. Usually unglazed ceramic is used; alternatives are described in annex B.

4.1.2 Connecting and body tubes, made from appropriate materials of low permeability to water and gas and connected by leakproof joints. Rigid or semi-rigid tubing shall be used to connect the tensiometer to the pressure sensor (see annex B). The function of the connecting tube may, in part or totally, be served by the body tube.

The body tube usually fills the hole remaining above or behind the tensiometer cup after inserting it into the soil. It is a rigid tube with the same outside diameter as the porous cup. In many designs, it is filled with water, but in others it forms a casing for smaller tubes connected to the porous cup and/or cables attached to a pressure transducer located behind the cup.

Table 1 — Conversions between soil water potential and its pressure and head equivalents

Parameter to be converted	Pressure equivalent	Head equivalent	Potential
	Pa	m	J/kg
Pressure equivalent (Pa)	1	$0,102 0 \times 10^{-3}$	10^{-3}
Head equivalent (m)	9 807	1	9,807
Potential (J/kg)	10^3	0,102 0	1

NOTES

1 To convert from the potential or its equivalent in the first vertical to another equivalent or potential, multiply by the factor given, for example:
a potential of 1 J/kg has a pressure equivalent of 10^3 Pa and a head equivalent of 0,102 0 m.

2 Acceleration due to gravity = $9,807 \text{ m/s}^2$

Density of water = $1 000 \text{ kg/m}^3$

4.1.3 Pressure sensors. Several forms are used in tensiometers, the most common being mercury manometers, Bourdon gauges and electrical pressure transducers. The use of other types of manometer is permissible. The accuracy of the pressure sensor determines how accurately the pressure of the water within the tensiometer can be measured.

Annex A details the construction and use of mercury manometers for use with tensiometers. The other pressure sensors are described in annex C.

The accuracy of Bourdon gauge and pressure transducer tensiometers shall be verified before installation and at least annually thereafter.

NOTE 5 The accuracy of instruments used in the field may be tested with a mercury manometer reference. The complete tensiometer assembly can be tested in the field by inserting a "T" piece into the connecting tube. When required, another connecting tube is attached to it for connection to a mercury manometer. Should greater accuracy be required for laboratory purposes, specialized testing equipment will be necessary.

4.2 Tensiometer construction

Details of materials for constructing tensiometers and of their construction are given in annex B. Since the interior of a tensiometer installed in unsaturated soil is under a partial vacuum, it is essential that all possible leakage points are made as secure as possible. The number of joints in the system shall be kept to the minimum possible. Adhesive joints shall be made so that the void space between components is filled completely. Joints relying on a tight fit of two materials, for example stoppers, shall be correctly sized, with as large an area of contact as possible.

The system is used in a damp environment. Hence all materials shall be chosen to resist moisture. This applies particularly to adhesives, some kinds of which may soften or swell (leading to failure of cemented parts) in damp conditions.

If a tensiometer assembly of new design or of untried materials is to be used, it shall be tested for leaks under pressure and/or under vacuum before installation. This procedure is recommended for all installations.

5 Procedure

5.1 Installation of tensiometers

Tensiometers may be installed vertically or horizontally, whichever is most suitable for the required purpose. Install each tensiometer so that the centre of the porous cup is at the depth at which measurement is required. Ensure minimal disturbance to the soil that will surround the tensiometer, both at the soil surface and at depth. Maximize the contact between the porous cup and the soil but minimize the smearing of the soil around the cup.

NOTE 6 Usually, a hole of the same diameter as the tensiometer is carefully bored and the tensiometer is inserted into it. Details of alternative procedures for preparing holes in which tensiometers can be inserted in the field are given in annex D. Methods similar to those described in annex D, but scaled down, should usually be chosen when installing tensiometers in plant containers, soil cores, lysimeters, etc.

Care shall be taken to protect the tensiometer system from temperature fluctuations. Fluctuations induce thermal expansion and contraction of parts of the system and the water within, which influence the pressure measurement. In the field, all exposed parts of the tensiometer shall, as far as practicable, be shielded from solar radiation. (This reduces thermal disturbance to the tensiometer reading and also prolongs the life of the components.) Precautions shall also be taken to prevent the percolation of rain or irrigation water down the side of the tensiometer to the cup. All equipment and the area around the tensiometer shall be protected from damage by rodents and other animals.

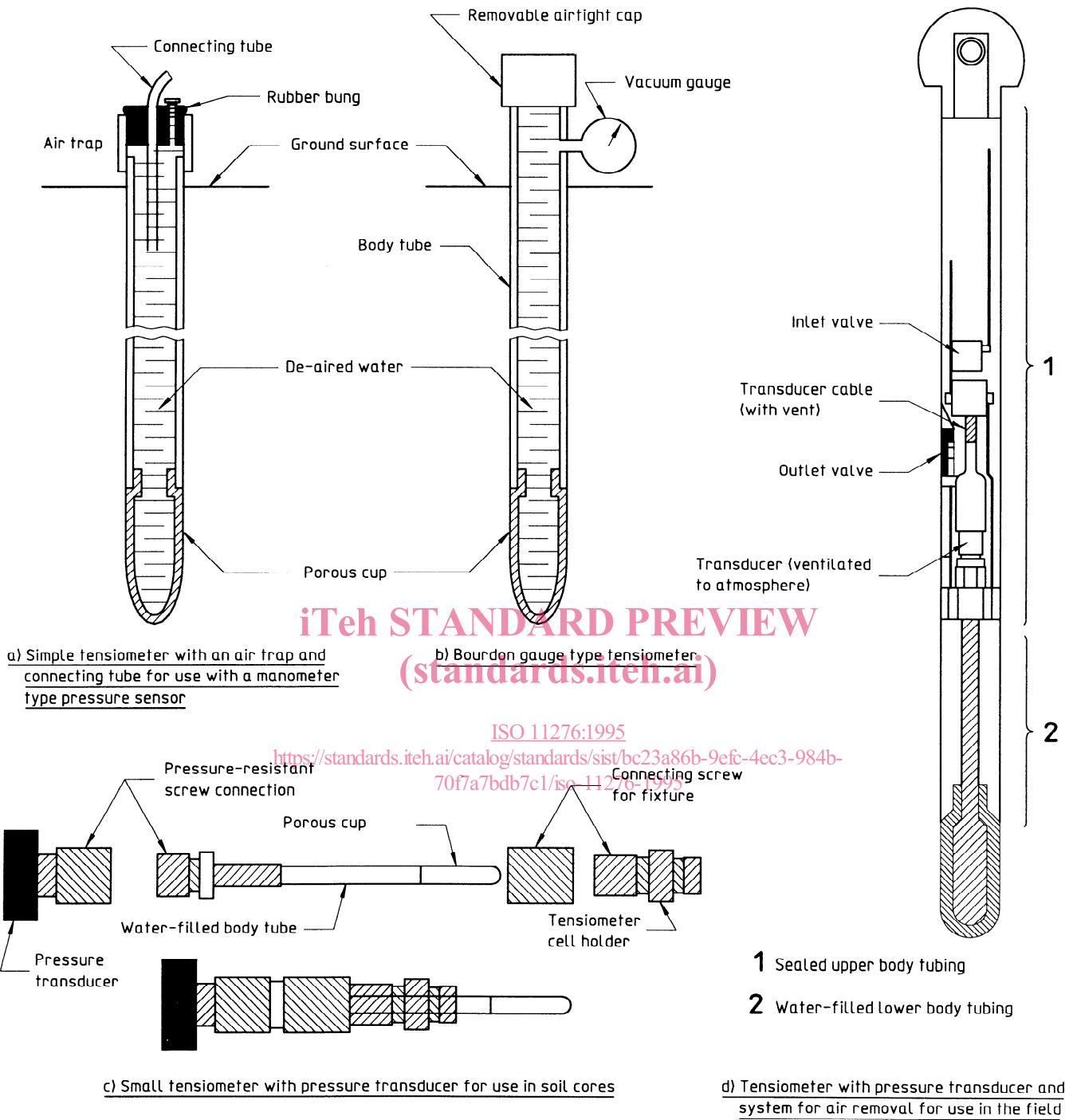

Figure 1 — The main elements of tensiometers incorporated into a variety of designs intended for field and laboratory use

5.2 Preparation of tensiometers for use

5.2.1 Preparation of de-aired water

Remove dissolved air from all the water used in the tensiometers, either by boiling it or with a vacuum system. Store the de-aired water so that no air can come into contact with it. Pour the de-aired water carefully and smoothly to minimize contact with air.

5.2.2 Filling the system with water

It is essential, when filling the assembled tensiometer system with the de-aired water, to avoid air being trapped inside it. Under field conditions, flush mercury manometer tensiometer systems as described in annex A.

NOTE 7 Under experimental laboratory conditions, it is preferable not to flush the system, as doing so can influence the water balance of a soil core.

It is possible to remove air from field systems equipped with Bourdon gauges or electrical pressure transducers, using a vacuum pump. This causes the air in the system to expand and bubble out. Water replaces the air when the vacuum is released. Sometimes, several such evacuation and repressurization cycles will be necessary to remove all the air.

5.3 Reading tensiometers

It is important to wait until the tensiometer system reaches hydraulic equilibrium before making readings.

NOTES

8 In a wet, coarse soil, reliable readings may be obtained within 1 h or less of setting up or servicing, whereas in drier soil, several days may be needed. It is recommended that an interval of at least 4 h and preferably 16 h (overnight) is allowed before reading field tensiometers, after setting up or servicing.

9 The frequency with which readings are made will depend on the purpose for which they are collected. In the upper 0,5 m or more, readings will change quickly in response to rainfall (hourly time-scale) and slightly less quickly in response to evaporation (daily time-scale). Changes will be slower at lower depths. However, if intervals of longer than a week elapse between readings, it will often be necessary to service manometer and Bourdon gauge type tensiometers before reliable readings can be obtained. To minimize the effect of diurnal temperature fluctuations and pore water pressure oscillations due to extraction of water by plants, it is preferable that tensiometers be read at the same hour each day that they are monitored, if the reading frequency is daily or less.

5.4 Servicing and maintenance of tensiometers

The major recurrent problem when operating tensiometers is air accumulation within them. Those having the pressure sensor placed behind the porous cup are less susceptible to this problem, but it is essential to ensure that any air accumulation is minimized by occasional purging.

With other types of equipment, small air bubbles in the air trap will not affect the accuracy of the tensiometer, but will lengthen its response time. The tensiometer shall be refilled with de-aired water whenever an air bubble of volume greater than 100 mm^3 ($0,1 \text{ cm}^3$) has collected in the air trap. The procedure is the same as that described in 5.2.2.

Persistent low readings of tensiometers (i.e. very negative readings) may be due to poor contact with the soil or leaks in the system. In the latter case, large amounts of air will collect in the tensiometer. If either problem is suspected, the tensiometer shall be removed and repaired.

Examination, and servicing if necessary, shall usually be performed at least once a week.

6 Expression of results

6.1 Method of calculation

The pressure sensor reading gives the sum of the pressure in the porous cup of the tensiometer and that of the water column between the pressure sensor and porous cup (see figure 2). The pore water pressure of the soil water at the position of the porous cup is calculated using the following formula:

$$p_p = p_x + \rho_w \cdot g \cdot a$$

where

p_p is the pore water pressure, in pascals, at the position of measurement, i.e. at the porous cup;

p_x is the pressure, in pascals, of the water in the pressure sensor in equilibrium with the porous cup, relative to atmospheric pressure;

a is the vertical distance, in metres, between the pressure sensor and the porous cup;

ρ_w is the density of water, in kilograms per cubic metre (approximately $1\,000 \text{ kg/m}^3$);

g is the acceleration due to gravity, in metres per second squared (approximately $9,81 \text{ m/s}^2$).

6.2 Precision

It is not possible to state the precision of a tensiometer measurement of pore water pressure. Several factors may individually, or in combination, affect the precision, i.e. the degree to which the pressure in the tensiometer differs from the true pore water pressure at the position of the porous cup. The accuracy of the measurement of the water pressure within a tensiometer is determined by the accuracy of the pressure sensor system employed.

All tensiometer systems take time to equilibrate with the external conditions. This response time depends on

- the type of pressure sensor, which determines the volume of water displaced for a given change in soil water potential;
- the capacity of the tensiometer system;
- the water conductivity of the porous material of the cup;
- the surface area of the porous cup.

In addition, in a given soil the response time is influenced by the contact with the soil and the hydraulic conductivity of the soil, which is a function of the soil water content.

If insufficient time has been allowed for the tensiometer and pressure sensor system to come into equilibrium with the soil, after either initially setting up or servicing the equipment, a pressure higher

(i.e. less negative) than the soil pore water pressure will be recorded. Alternatively, or in addition, the soil pore water pressure may be changing quite rapidly in time as a consequence of, for example, a wetting front moving through the soil, in which case equilibrium between the soil and tensiometer cannot be obtained.

7 Test report

The test report shall contain the following information:

- a) a reference to this International Standard;
- b) an accurate site description of the measuring location and of the soil profile;
- c) an accurate description of the tensiometers and pressure sensors used;
- d) the depth of the tensiometers and an accurate description of the installation procedure;
- e) the pore water pressure measured in kilopascals, as a function of depth and time;
- f) any remarks that are important to the interpretation of the results, such as whether the tensiometers were recently purged of air, and observations with respect to the hydrological and meteorological conditions before and during the measurements;
- g) any special details which may have been noted during the measurements;
- h) details of any relevant operations not specified in this International Standard, or regarded as optional.

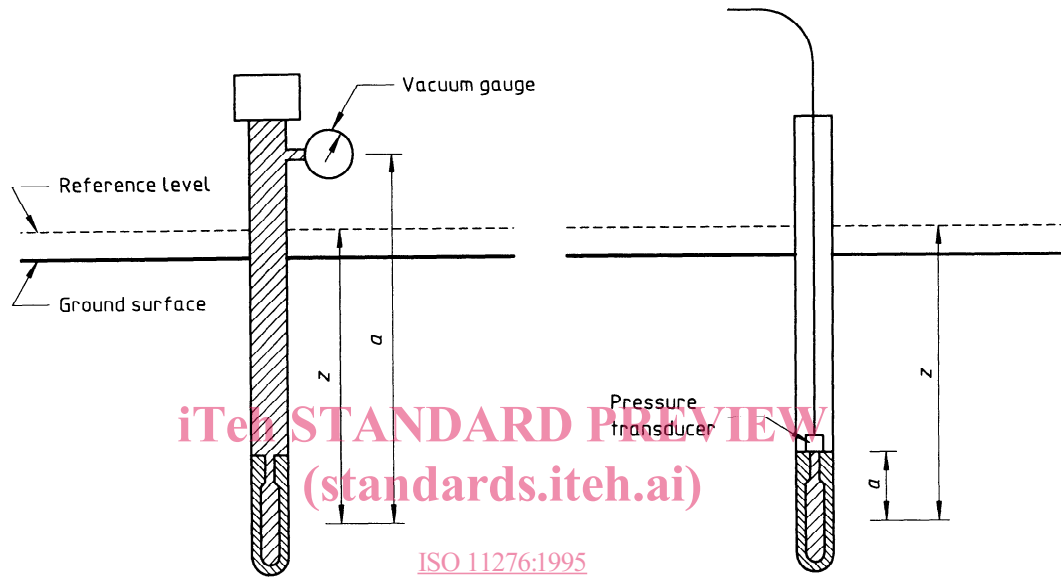

ISO 11276:1995

[https://standards.iteh.ai/catalog/standards/sist/bc23a86b-9efc-4ec3-984b-](https://standards.iteh.ai/catalog/standards/sist/bc23a86b-9efc-4ec3-984b-70f7a7bdh7c1/iso-11276-1995)

[70f7a7bdh7c1/iso-11276-1995](https://standards.iteh.ai/catalog/standards/sist/bc23a86b-9efc-4ec3-984b-70f7a7bdh7c1/iso-11276-1995)

Figure 2 — Components of the pressure measured by a sensor attached to a tensiometer

Annex A (normative)

Construction and use of mercury manometers

A.1 Introduction

WARNING — Mercury is hazardous to people, animals and the environment and accordingly great care is required when using mercury manometers. All users should be aware of the nature of the hazard, and be familiar with the precautions necessary to prevent spills and with procedures for cleaning up any mercury spillage.

The mercury manometer is suitable for many applications. Under constant temperature conditions, as in a laboratory, the tensiometer water pressure can be measured as accurately as the mercury level can be measured against a graduated scale, i.e. to an accuracy of 0,1 kPa. Under field conditions, the accuracy of a mercury manometer is about 0,4 % plus the 0,1 kPa error due to parallax. Mercury manometers have the advantage of being simple to construct at a relatively low cost.

A.2 Construction

Figure A.1 illustrates three mercury manometers with a common reservoir, mounted on a board. Each manometer is joined to a tensiometer via a connecting tube.

NOTE 10 Where an array of several tensiometers is required in a soil profile, it is preferable to mount the manometers on the same board and to use a common reservoir so that all measurements are based on the same data.

If the manometer tube is not integral with the connecting tube, great care shall be taken to ensure a gas-tight seal between them. The manometer tube shall have an internal diameter of between approxi-

mately 0,5 mm and 2,0 mm, shall be of low permeability to gas and water and be sufficiently transparent that the water/mercury interface can be seen easily. The internal surface of the manometer tube shall be smooth, to discourage collection of dirt inside the tube.

NOTE 11 Polyamide 12, polyamide 66 (both are types of nylon) and glass are suitable materials for capillary tubes. The two types of nylon are also suitable for connecting tubes. (see B.4).

The manometer tube is mounted on a scale, graduated in small units, often millimetres. There shall be no gap between the two, to minimize parallax errors when reading the mercury level.

The bottom end of the manometer tube dips into a mercury reservoir which has a cover to prevent spillage. The end of the tube shall be cut at an angle to allow free flow of mercury. It is recommended that a tray be fixed below the mercury reservoir as a further precaution against spillage of mercury.

NOTE 12 The surface area of the reservoir should be large enough to prevent the level of the mercury in the reservoir from falling more than 2 mm when all the manometer tubes, which share the same reservoir, have 600 mm of mercury in them. This means that the surface area of the reservoir should be more than 300 times that of the combined cross-sectional areas of the manometer tubes. If the reservoir is smaller, the mercury level can be recorded each time that measurements are made and a correction may then be applied. The reservoir should be constructed so that the end of each manometer tube is separated from the end of adjacent tubes, to avoid water or air passing from one to another during servicing. The cover should be vented to ensure that atmospheric pressure changes affect the mercury.

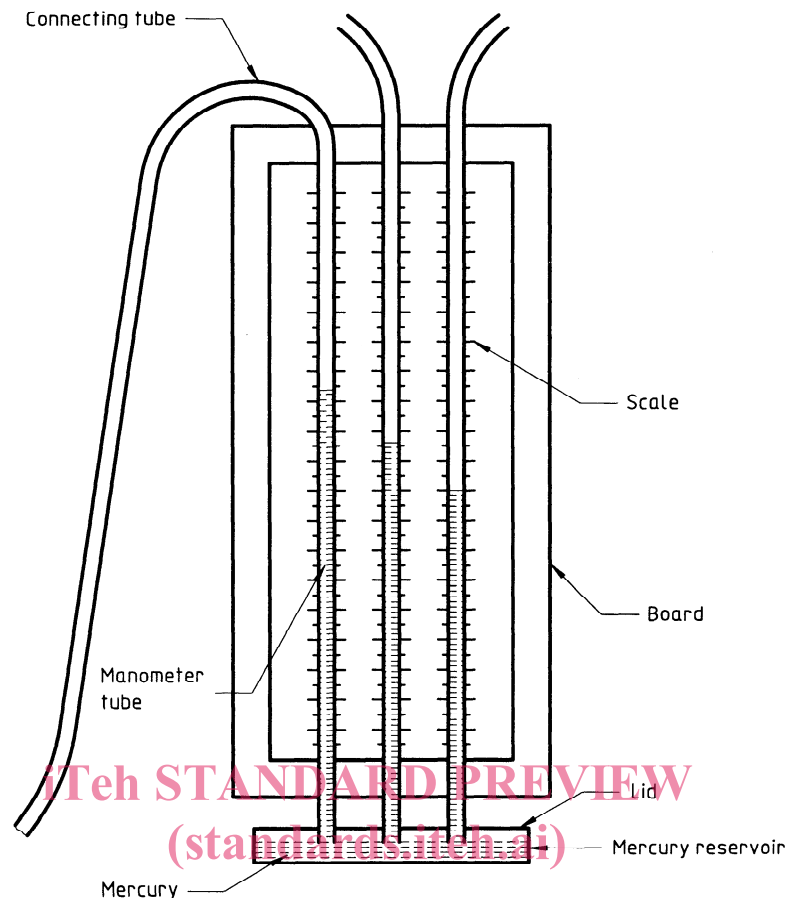

ISO 11276:1995
 Figure A.1 — Mercury manometer system for use with tensiometers
<https://standards.iteh.ai/catalog/standards/sist/bc23a95b-0af-40c2-984b-70f7a7bdb7c1/iso-11276-1995>

SAFETY PRECAUTIONS — If mercury is spilt at any time, it shall be thoroughly cleaned up immediately. Should spillage occur in the field, any contaminated soil and vegetation shall be removed and taken to a hazardous waste specialist for recycling.

The manometer tubes, scale and mercury reservoir shall be mounted on a vertical, rigid board, so that the scale marks are horizontal. The manometer tubes shall be attached rigidly to the board and scale, so that they lie flat against the scale. For outdoor use, the board shall be constructed of a material which resists distortion under prevailing environmental conditions. The board itself shall be anchored in place, so that it cannot be disturbed by, for instance, wind. It shall be mounted so that the scale and manometer tubes face away from the sun.

NOTE 13 The connecting tube may be encased in another tube, and the board and the manometer tubes enclosed inside a light-coloured box, with a door allowing the manometers to be read. Thus all the equipment can be shaded. For safety, the box should be kept locked when the manometers are not being attended to.

The connecting tubes shall be cut to a length which is no longer than necessary and, if outdoors, be secured to minimize flapping in the wind, which may cause the mercury levels to oscillate. The end of each connecting tube shall terminate inside the tensiometer body near to its bottom, to ensure that there is a continuous water column from the porous cup to the mercury surface in the manometer tube. Care shall be taken to ensure that the connecting tube does not adhere to the porous cup, thus preventing the movement of fluid through it, by cutting the tube at an angle.

A.3 Filling the system with water

When the system is assembled and fixed in position, fill the tensiometers with de-aired water, and then allow to settle with the air-trap open. Then fill each tensiometer to the top and use a syringe to inject de-aired water into the top of the tensiometer, to flush all air from the connecting tube and the manometer out through the reservoir.